

Features of the Slide Rail

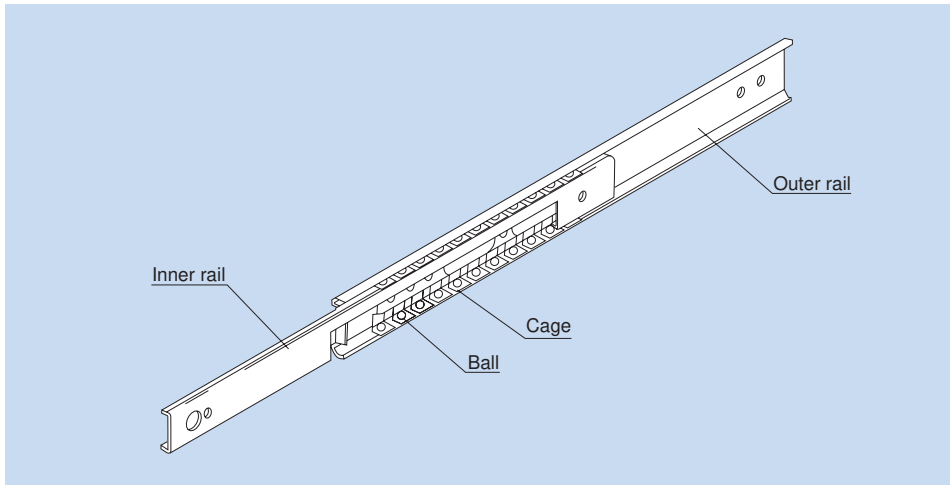

Fig.1 Structure of Slide Rail Model FBL

Structure and Features

Slide Rail model FBL is a thin, compact, lightweight and ultra-low price slide unit for finite motion. It has two rows of balls placed between an inner rail (made of a steel sheet roll-formed with precision) and an outer rail. The balls are evenly spaced by a cage press-molded with precision, thus eliminating friction between balls and achieving a smooth slide mechanism.

Since model FBL achieves smooth straight motion with easy installation, it can be used in a wide range of applications such as photocopiers, measuring instruments, telecommunication equipment, medical equipment, automatic vending machines and various types of office equipment.

[Unit Type That Allows Easy Installation]

Since the clearance and the motion of the slide unit are optimally adjusted, simply mounting the unit onto the base or the table using screws will achieve a slide mechanism with virtually no running noise.

[Thin and Compact]

Since the sectional shape is thin designed, this slide pack only requires a small side space for installation. In addition, a desired number of slide pack units can be installed in parallel according to the load conditions.

[Maintenance-free Operation]

Since the slide rail is treated with zinc plating, it is highly corrosion resistant. In addition, the slide unit contains lithium soap-based grease, which is highly stable against oxidation.

Types of the Slide Rail

Types and Features

[Single Slides for Light Load]

Model FBL 27S

[Specification Table⇒B-542](#)

The most compact slide rail from THK.

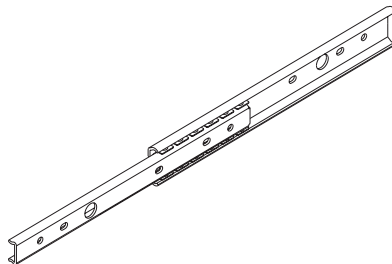

Model FBL 27S

Model FBL 27S-P14

[Specification Table⇒B-543](#)

An inner rail pulling type of model FBL 27S. Releasing the automatic free disconnection spring attached on the inner rail allows the slide rail to be pulled out. When stored, the spring is automatically released unidirectionally under a certain pressure.

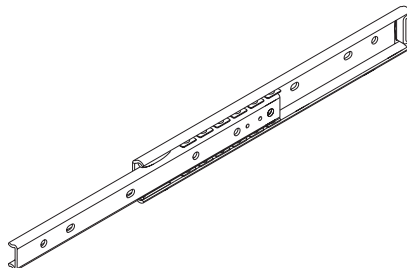

Model FBL 27S-P14

Model FBL 35S

[Specification Table⇒B-544](#)

A single slide type of Slide Rail with the most fundamental shape.

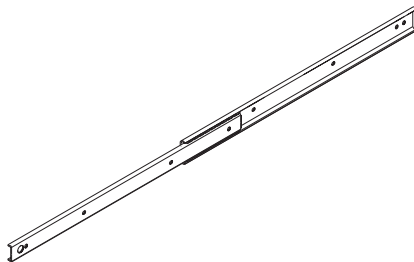

Model FBL 35S

Model FBL 35M

[Specification Table⇒B-545](#)

An inner rail pulling type of model FBL 35S. It stops by frictional resistance when the slide rail is fully opened, and is pulled out when being pulled further with force.

(brake-stop type)

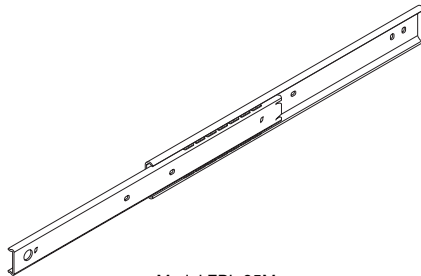

Model FBL 35M

Model FBL 35J

[Specification Table⇒B-546](#)

Based on model FBL 35M, this model has a lead ball that serves as a guide when the inner rail is inserted.

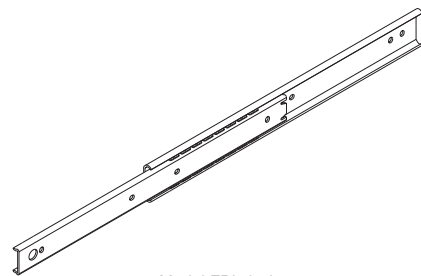

Model FBL 35J

Model FBL 35J-P13

[Specification Table⇒B-547](#)

An inner rail pulling type of model FBL 35S. Releasing the disconnection spring attached on the inner rail allows the slide rail to be pulled out. When folded, the locked state with the disconnect spring is manually released.

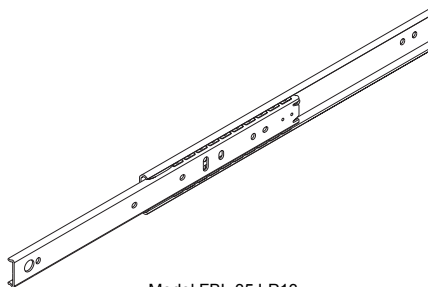

Model FBL 35J-P13

Model FBL 35J-P14

[Specification Table⇒B-548](#)

An inner rail pulling type of model FBL 35S. Releasing the automatic free disconnection spring attached on the inner rail allows the slide rail to be pulled out. When stored, the spring is automatically released unidirectionally under a certain pressure.

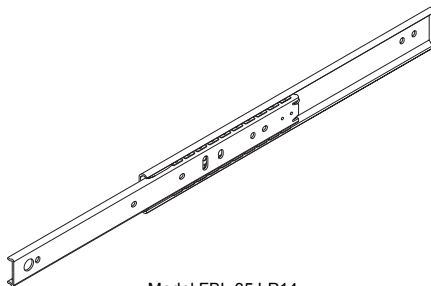

Model FBL 35J-P14

Model FBL 35B

[Specification Table⇒B-549](#)

A brake-stop type of model FBL 35M. It can be mounted on the bottom face of a moving object when used.

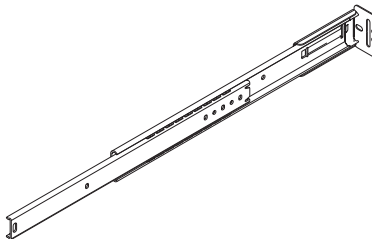

Model FBL 35B

[Single Slides for Medium Load]

Model FBL 35T

A single slide combining two units of model FBL 35S. When folded, the locked state with the disconnect spring is manually released.

[Specification Table⇒B-550](#)

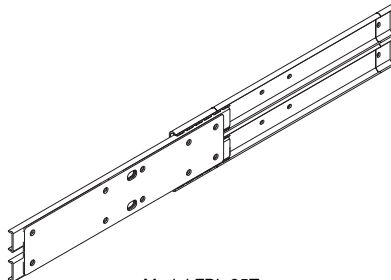

Model FBL 35T

[Double Slides for Light Load]

Model FBL 27D

A double-slide type that combines two units of model FBL 27S back-to-back. It is widely used in various types of OA equipment.

[Specification Table⇒B-551](#)

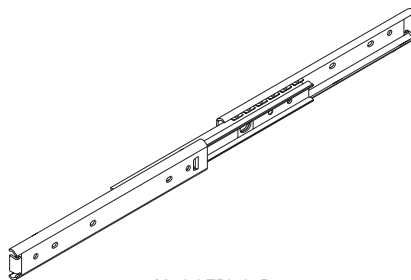

Model FBL 27D

Model FBL 35E-P14

A three-rail, double-slide type that allows a long stroke in a small space. Releasing the automatic free disconnection spring attached on the inner rail allows the inner rail to be pulled out. When folded, the locked state is automatically released under a certain pressure in the folding direction.

[Specification Table⇒B-552](#)

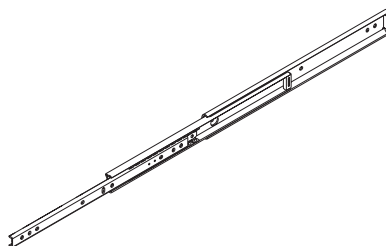

Model FBL 35E-P14

[Double Slides for Medium Load]

Model FBL 35G-P13

A double-slide type that combines two units of model FBL 35S front-to-front. Releasing the automatic free disconnection spring attached on the inner rail allows the inner rail to be pulled out. When folded, the locked state with the disconnect spring is manually released. It is also equipped with a pull-lock mechanism that functions when the slide rail is fully opened.

[Specification Table⇒B-553](#)

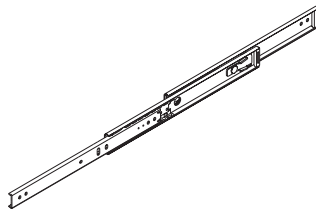

Model FBL 35G-P13

Model FBL 35G-P14

A double-slide type that combines two units of model FBL 35S front-to-front. Releasing the automatic free disconnection spring attached on the inner rail allows the inner rail to be pulled out. When folded, the lock state with the disconnect spring can automatically be released under a certain pressure in the folding direction. It is also equipped with a pull-lock mechanism that functions when the slide rail is fully opened.

[Specification Table⇒B-554](#)

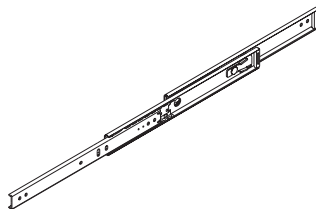

Model FBL 35G-P14

Model FBL 35D

A double-slide type that combines two units of model FBL 35S back-to-back. It is extensively used regardless of the industry.

[Specification Table⇒B-555](#)

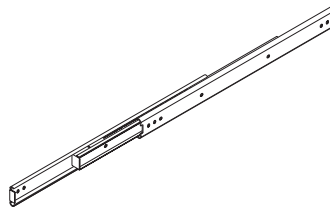

Model FBL 35D

Model FBL 35W

A double-slide type based on model FBL 35S that achieves a thickness of one single-slide unit.

[Specification Table⇒B-556](#)

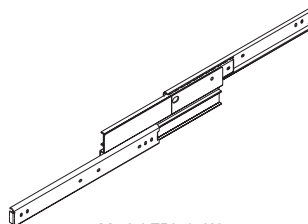

Model FBL 35W

Model FBL 51H

A three-rail, double-slide type that allows for a long stroke. With the smallest thickness, this model can be used in a space-saving location even under a large load.

[Specification Table⇒B-557](#)

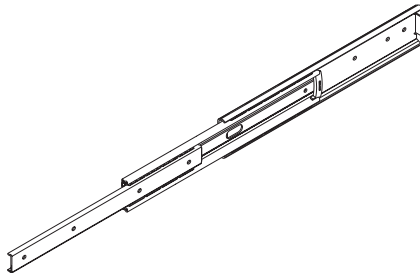

Model FBL 51H

Model FBL 51H-P13

A three-rail, double-slide type that allows a long stroke. With the smallest thickness, this model can be used in a space-saving location even under a large load. Releasing the automatic free disconnection spring attached on the inner rail allows the inner rail to be pulled out. When folded, the locked state with the disconnect spring is manually released. It is also equipped with a lock mechanism that functions when the slide rail is fully opened.

[Specification Table⇒B-558](#)

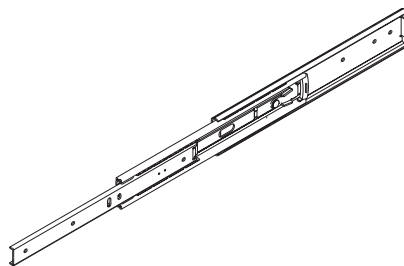

Model FBL 51H-P13

Model FBL 51H-P14

A three-rail, double-slide type that allows a long stroke. With the smallest thickness, this model can be used in a space-saving location even under a large load. Releasing the automatic free disconnection spring attached on the inner rail allows the inner rail to be pulled out. When folded, the locked state is automatically released under a certain pressure in the folding direction.

[Specification Table⇒B-559](#)

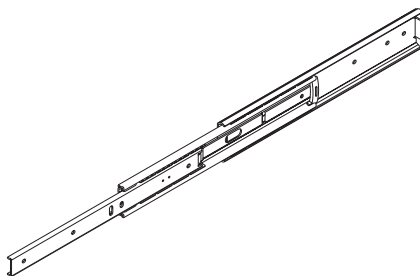

Model FBL 51H-P14

[Double Slides for Heavy Load]

Model FBL 35K

A double-slide type combining 4 units of model FBL 35S. It achieves the largest permissible load among all types and is optimal for opening/closing heavy objects.

Specification Table⇒B-560

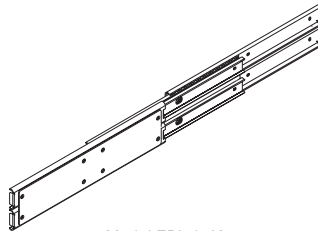

Model FBL 35K

Model FBL 56H

A double-slide type with the largest permissible load among the three rails. It is used extensively in various types of OA furniture.

Specification Table⇒B-561

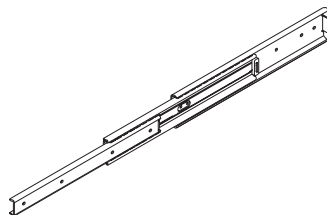

Model FBL 56H

Model FBL 56H-P13

A double-slide type with the largest permissible load among the three rails. Releasing the automatic free disconnection spring attached on the inner rail allows the inner rail to be pulled out. When folded, the locked state with the disconnect spring is manually released. It is also equipped with a lock mechanism that functions when the slide rail is fully opened.

Specification Table⇒B-562

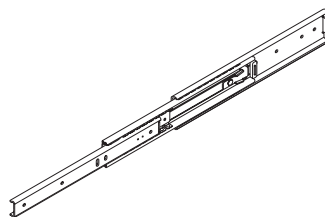

Model FBL 56H-P13

Model FBL 561H-P14

A double-slide type with the largest permissible load among the three rails. Releasing the automatic free disconnection spring attached on the inner rail allows the inner rail to be pulled out. When folded, the locked state is automatically released under a certain pressure in the folding direction.

Specification Table⇒B-563

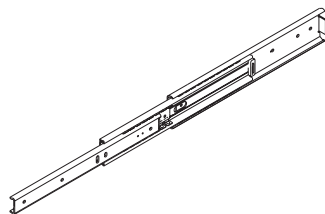

Model FBL 561H-P14

[\[Linear Type Slides\]](#)

Light Load Type Model FBL 35F

[Specification Table⇒B-564](#)

Using a flange type that can easily be mounted, this slide-type model is capable of performing straight, finite motion.

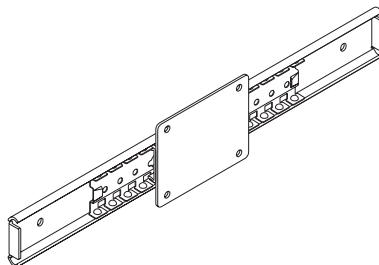

Light Load Type Model FBL 35F

Medium Load Type Model FBL 56F

[Specification Table⇒B-565](#)

Using a flange type that can easily be mounted, this slide-type model is capable of performing straight, finite motion. It is optimal for locations under a large working load.

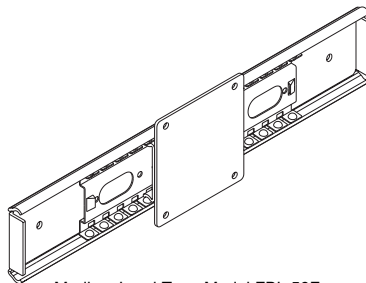

Medium Load Type Model FBL 56F

Heavy Load Type Model FBL 48DR

[Specification Table⇒B-566](#)

A heavy-load, low-friction slide rail developed for sliding heavy doors.

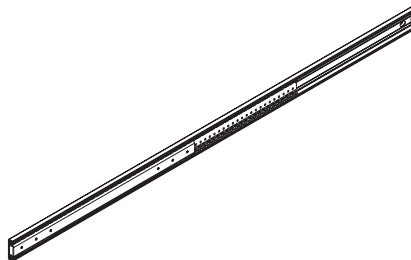

Heavy Load Type Model FBL 48DR

[Aluminum Alloy Slide Rail]**Light Load Type Model E15**

The lightest and most compact single slide in the aluminum alloy series. It is especially suitable for locations with magnetism, locations requiring antirust measures and locations where much importance is given to appearance.

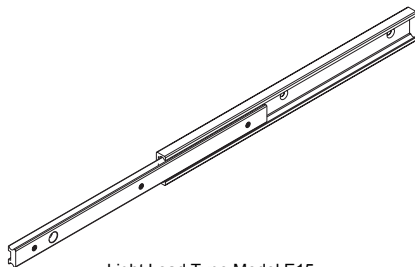
[Specification Table⇒B-567](#)

Light Load Type Model E15

Light Load Type Model E20

A single-slide with the most fundamental shape in the aluminum alloy series. It is especially suitable for locations with magnetism, locations requiring antirust measures and locations where much importance is given to appearance.

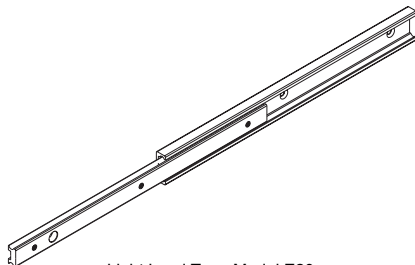
[Specification Table⇒B-568](#)

Light Load Type Model E20

Light Load Type Model D20

The lightest and most compact double slides in the aluminum alloy series. It is especially suitable for locations with magnetism, locations requiring antirust measures and locations where much importance is given to appearance.

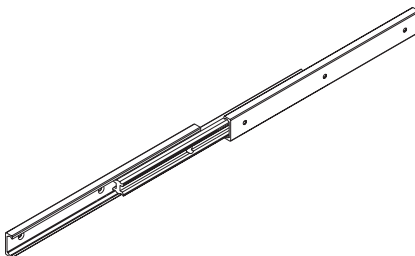
[Specification Table⇒B-569](#)

Light Load Type Model D20

Classification Table for Slide Rails

Slide Rail

Single Slide

Double Slide

For Light Load

Model FBL27S Model FBL35J
Model FBL27S-P14 Model FBL35J-P13
Model FBL35J-P14

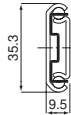
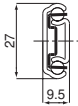

Model FBL35S

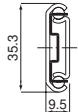

Model E15
(Made of Aluminum)



Model FBL35M

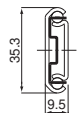

Model E20
(Made of Aluminum)



Model FBL35B

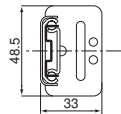

For Medium Load

Model FBL35T

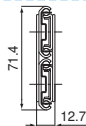

For Light Load

Model FBL27D Model FBL35E-P14

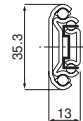
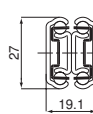

Model D20 (Made of Aluminum)

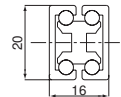

For Heavy Load

Model FBL56H

Model FBL56H-P13

Model FBL56H-P14

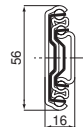

Model FBL35K

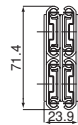

Linear Type Slide

For Medium Load

Model FBL35G-P13

Model FBL51H

Model FBL35G-P14

Model FBL51H-P13

Model FBL51H-P14

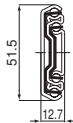
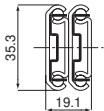

Model FBL35D

Model FBL35W

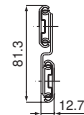
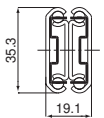

For Light Load

Model FBL35F

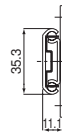

For Medium Load

Model FBL56F

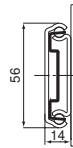

For Heavy Load

Model FBL48DR

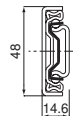

Mounting the Slide Rail

[Mounting Screws of the Slide Rail]

The slide rail is designed to be mounted using M4 screws. Since the mounting space is small as shown in Fig.1, we recommend using button-head bolt or binding-head bolt (JIS B 1111 annex).

Note) For models FBL27S/27S-P14/27D, use M4 binding-head bolt, or M3 button-head bolt or binding-head bolt.

Note) For model FBL48DR, use M5×8 mounting screw.

Note) For model E15, use M2.6 countersunk screw.

Note) For models E20 and D20, use M3 countersunk screw.

Note) For model FBL 35E, use M3 button-head bolts or binding-head bolts.

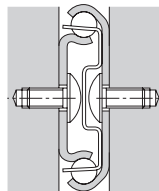

Fig.1

[Attaching the Slide Rail]

While keeping the maximum stroke, mount the outer rail at the section where the inner rail and the outer rail overlap, slide the inner rail backward, and then secure the rail using a screw through the access hole.

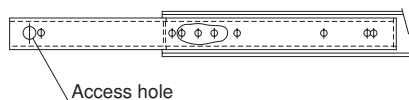

Fig.2

[Permissible Load and Mounting Orientation]

For use other than with the mounting orientation shown in Fig.3, contact THK.

The permissible load of the Slide Rail indicates the load in the direction P_a that two rails can receive in the middle of the inner rail length at the maximum stroke.

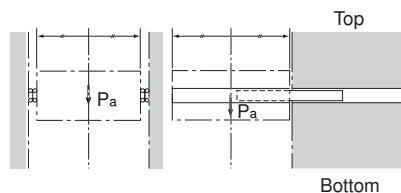

Fig.3

[Surface Treatment]

The surface of the Slide Rail is treated with electro-galvanizing (gloss chromate treatment) as standard. Colored chromate treatment and chrome plating are also available. Contact THK for details.

Precautions on Use

Slide Rail

[Handling]

- (1) Tilting a slide rail may cause it to fall by its own weight.
- (2) Dropping or hitting the Slide Rail may damage it. Giving an impact force to the slide rail could also cause damage even if the product looks intact.

[Precautions on Use]

- (1) When mounting the Slide Rail, use care to always keep both rails in parallel.
- (2) Entrance of foreign material may cause damage to the Slide Rail or functional loss.
- (3) Avoid using the product at other than normal temperature, or using it in harsh conditions such as intensive reciprocations that generate frictional heat and environments with water or dust.
- (4) The durability of the Slide Rail varies depending on factors such as the drawing dimension, travel distance, mounting conditions and environment in addition to operating frequency. Take these factors into account when making a selection.

[Storage]

When storing the Slide Rail, avoid high temperature, low temperature and high humidity.

Model FBL 27S

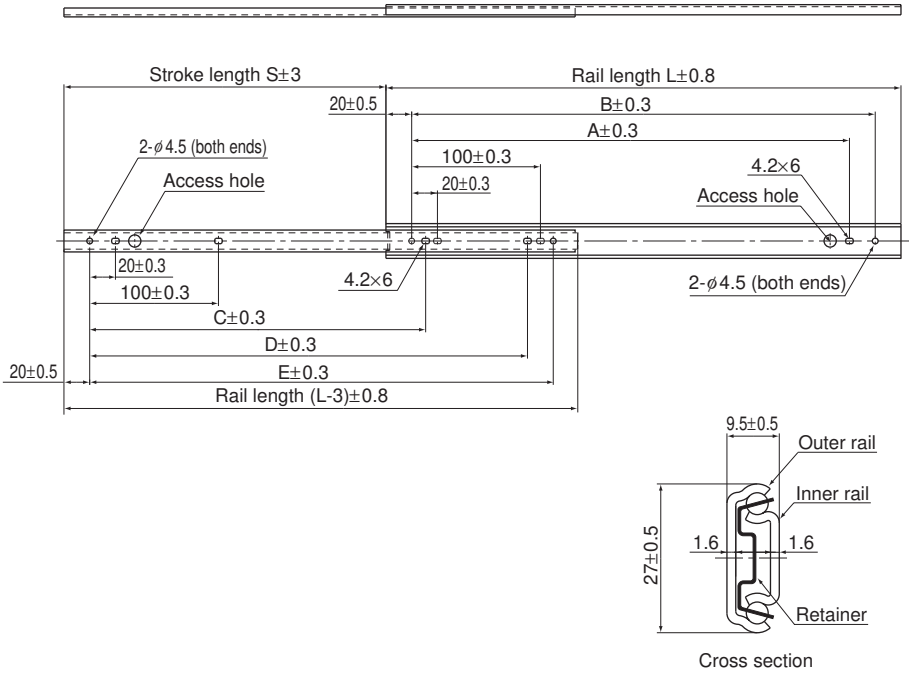

Unit: mm

Rail length L (±0.8)	Stroke S (±3)	Mounting hole dimensions					Mounting hole		Permissible load N/pair	Mass kg/pair
		A	B	C	D	E	Inner rail	Outer rail		
200	135	140.0	160.0	—	140.0	160.0	5	5	260	0.32
250	185	190.0	210.0	150.0	190.0	210.0	6	5	240	0.40
300	222	240.0	260.0	190.0	240.0	260.0	6	5	240	0.48
350	260	290.0	310.0	225.0	290.0	310.0	6	5	230	0.56
400	297	340.0	360.0	265.0	340.0	360.0	6	5	210	0.64
450	334	390.0	410.0	300.0	390.0	410.0	6	5	200	0.72
500	371	440.0	460.0	337.0	440.0	460.0	6	5	180	0.80

Note) The permissible load and the mass each indicate the value for a pair of 2 units.

Model number coding

FBL27S +300L

Model number

Overall rail length (in mm)

Model FBL 27S-P14

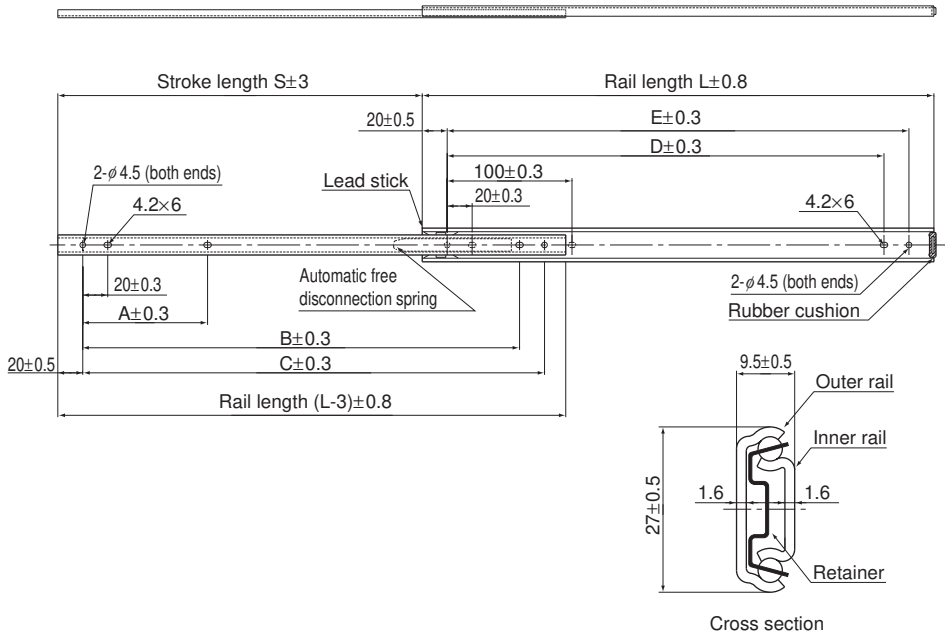

Unit: mm

Rail length L (± 0.8)	Stroke S (± 3)	Mounting hole dimensions					Mounting hole		Permissible load N/pair	Mass kg/pair
		A	B	C	D	E	Inner rail	Outer rail		
200	116	65.0	—	170.0	140.0	160.0	4	5	260	0.32
250	152	100.0	—	210.0	190.0	210.0	4	5	240	0.40
300	202	100.0	—	260.0	240.0	260.0	4	5	240	0.48
350	251	100.0	—	310.0	290.0	310.0	4	5	230	0.56
400	297	100.0	—	360.0	340.0	360.0	4	5	210	0.64
450	332	100.0	390.0	410.0	390.0	410.0	5	5	210	0.72
500	371	100.0	440.0	460.0	440.0	460.0	5	5	200	0.80
550	407	100.0	490.0	510.0	490.0	510.0	5	5	180	0.80

Note) The permissible load and the mass each indicate the value for a pair of 2 units.

Model number coding

FBL27S-P14 +500L

Model number

Overall rail length (in mm)

Model FBL 35S

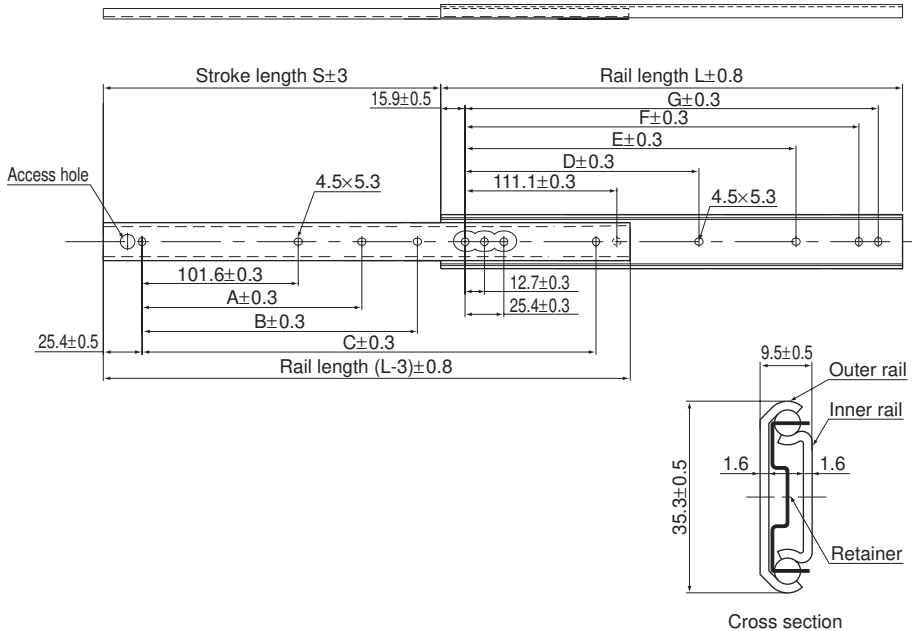

Unit: mm

Rail length L (±0.8)	Stroke S (±3)	Mounting hole dimensions							Mounting hole		Permissible load N/pair	Mass kg/pair
		A	B	C	D	E	F	G	Inner rail	Outer rail		
305	229	—	152.4	254.0	—	149.2	260.3	273.0	4	7	490	0.6
356	279	—	203.2	304.8	—	200.0	311.1	323.8	4	7	400	0.7
406	305	—	254.0	355.6	—	250.8	361.9	374.6	4	7	390	0.8
457	330	203.2	304.8	406.4	212.7	301.6	412.7	425.4	5	8	380	0.9
508	381	228.6	355.6	457.2	238.1	352.4	463.5	476.2	5	8	330	1.0
559	406	254.0	406.4	508.0	263.5	403.2	514.3	527.0	5	8	320	1.1
610	432	279.4	457.2	558.8	288.9	454.0	565.1	577.8	5	8	310	1.2
660	483	304.8	508.0	609.6	314.3	504.8	615.8	628.6	5	8	280	1.3
711	508	330.2	558.8	660.4	339.7	555.6	666.7	679.4	5	8	270	1.4

Note) The permissible load and the mass each indicate the value for a pair of 2 units.

Model number coding

FBL35S +457L

Model number Overall rail length (in mm)

Model FBL 35M

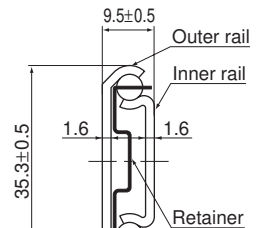
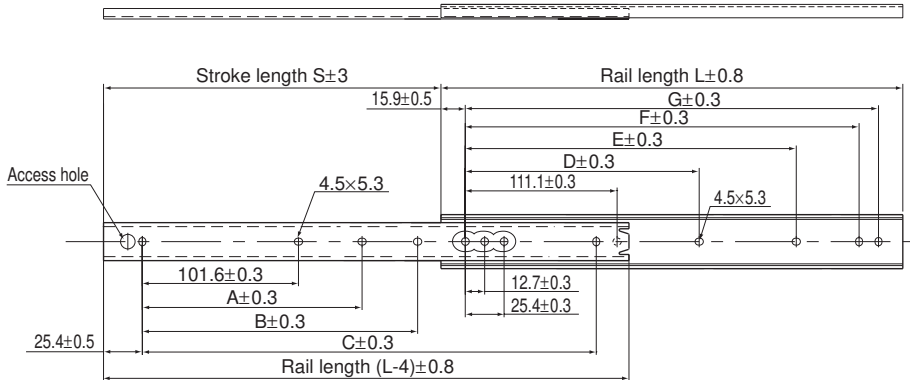

Cross section

Unit: mm

Rail length L (± 0.8)	Stroke S (± 3)	Mounting hole dimensions							Mounting hole		Permissible load N/pair	Mass kg/pair
		A	B	C	D	E	F	G	Inner rail	Outer rail		
305	229	—	152.4	254.0	—	149.2	260.3	273.0	4	7	490	0.6
356	279	—	203.2	304.8	—	200.0	311.1	323.8	4	7	400	0.7
406	305	—	254.0	355.6	—	250.8	361.9	374.6	4	7	390	0.8
457	330	203.2	304.8	406.4	212.7	301.6	412.7	425.4	5	8	380	0.9
508	381	228.6	355.6	457.2	238.1	352.4	463.5	476.2	5	8	330	1.0
559	406	254.0	406.4	508.0	263.5	403.2	514.3	527.0	5	8	320	1.1
610	432	279.4	457.2	558.8	288.9	454.0	565.1	577.8	5	8	310	1.2
660	483	304.8	508.0	609.6	314.3	504.8	615.9	628.6	5	8	280	1.3
711	508	330.2	558.8	660.4	339.7	555.6	666.7	679.4	5	8	270	1.4

Note) The permissible load and the mass each indicate the value for a pair of 2 units.

Model number coding

FBL35M +406L

Model number Overall rail length (in mm)

Model FBL 35J

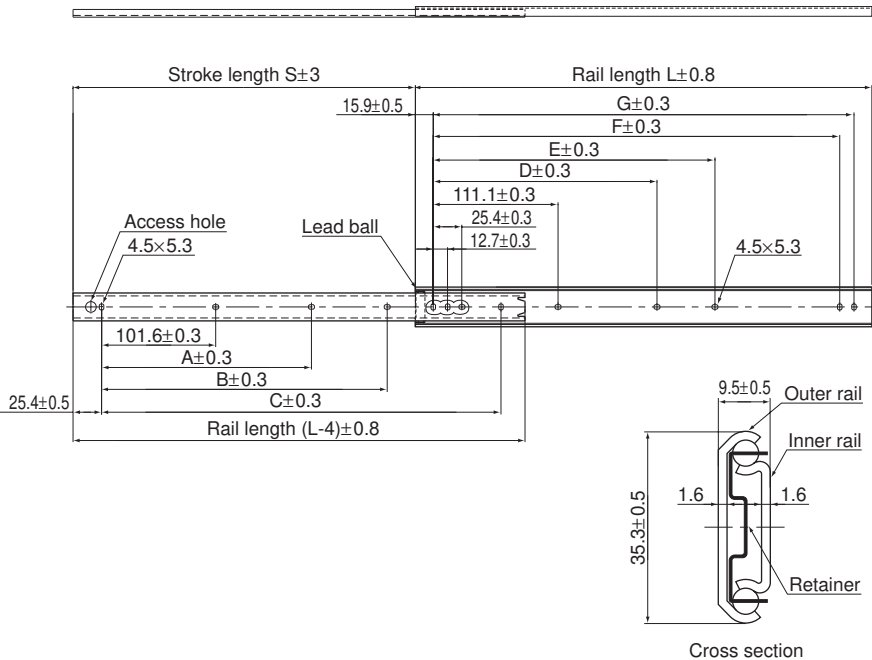

Unit: mm

Rail length L (±0.8)	Stroke S (±3)	Mounting hole dimensions							Mounting hole		Permissible load N/pair	Mass kg/pair
		A	B	C	D	E	F	G	Inner rail	Outer rail		
305	229	—	152.4	254.0	—	149.2	260.3	273.0	4	7	490	0.6
356	279	—	203.2	304.8	—	200.0	311.1	323.8	4	7	400	0.7
406	305	—	254.0	355.6	—	250.8	361.9	374.6	4	7	390	0.8
457	330	203.2	304.8	406.4	212.7	301.6	412.7	425.4	5	8	380	0.9
508	381	228.6	355.6	457.2	238.1	352.4	463.5	476.2	5	8	330	1.0
559	406	254.0	406.4	508.0	263.5	403.2	514.3	527.0	5	8	320	1.1
610	432	279.4	457.2	558.8	288.9	454.0	565.1	577.8	5	8	310	1.2
660	483	304.8	508.0	609.6	314.3	504.8	615.9	628.6	5	8	280	1.3
711	508	330.2	558.8	660.4	339.7	555.6	666.7	679.4	5	8	270	1.4

Note) The permissible load and the mass each indicate the value for a pair of 2 units.

Model number coding

FBL35J +660L

Model number Overall rail length (in mm)

Model FBL 35J-P13

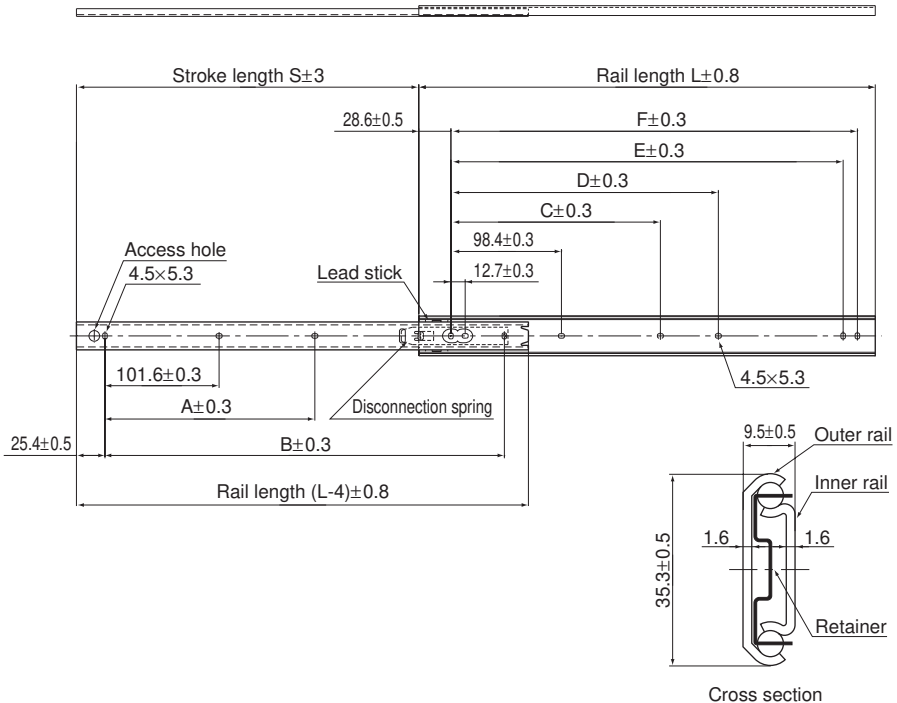

Unit: mm

Rail length L (±0.8)	Stroke S (±3)	Mounting hole dimensions						Mounting hole		Permissible load N/pair	Mass kg/pair
		A	B	C	D	E	F	Inner rail	Outer rail		
305	224	152.4	—	136.5	—	247.6	260.3	3	6	490	0.6
356	275	203.2	—	187.3	—	298.4	311.1	3	6	400	0.72
406	315	254.0	—	238.1	—	349.2	361.9	3	6	390	0.84
457	330	203.2	406.4	200.0	228.9	400.0	412.7	4	7	380	0.96
508	381	228.6	457.2	225.4	339.7	450.8	463.5	4	7	330	1.04
559	406	254.0	508.0	250.8	390.5	501.6	514.3	4	7	320	1.16
610	432	279.4	558.8	276.2	441.3	552.4	565.1	4	7	310	1.24
660	483	304.8	609.6	301.6	492.1	603.2	615.9	4	7	280	1.36
711	493	330.2	660.4	327.0	542.9	654.0	666.7	4	7	270	1.48

Note) The permissible load and the mass each indicate the value for a pair of 2 units.

Model number coding

FBL35J-P13 +559L

Model number

Overall rail length (in mm)

Model FBL 35J-P14

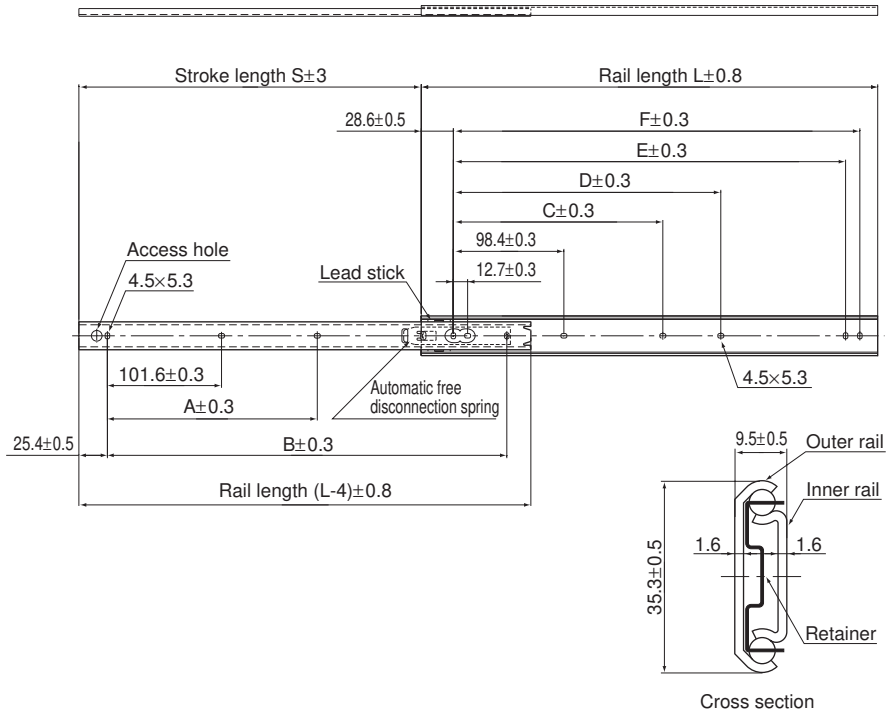

Cross section

Unit: mm

Rail length L (±0.8)	Stroke S (±3)	Mounting hole dimensions						Mounting hole		Permissible load N/pair	Mass kg/pair
		A	B	C	D	E	F	Inner rail	Outer rail		
305	224	152.4	—	136.5	—	247.6	260.3	3	6	490	0.6
356	275	203.2	—	187.3	—	298.4	311.1	3	6	400	0.72
406	315	254.0	—	238.1	—	349.2	361.9	3	6	390	0.84
457	330	203.2	406.4	200.0	228.9	400.0	412.7	4	7	380	0.96
508	381	228.6	457.2	225.4	339.7	450.8	463.5	4	7	330	1.04
559	406	254.0	508.0	250.8	390.5	501.6	514.3	4	7	320	1.16
610	432	279.4	558.8	276.2	441.3	552.4	565.1	4	7	310	1.24
660	483	304.8	609.6	301.6	492.1	603.2	615.9	4	7	280	1.36
711	493	330.2	660.4	327.0	542.9	654.0	666.7	4	7	270	1.48

Note) The permissible load and the mass each indicate the value for a pair of 2 units.

Model number coding

FBL35J-P14 +559L

Model number

Overall rail length (in mm)

Model FBL 35B

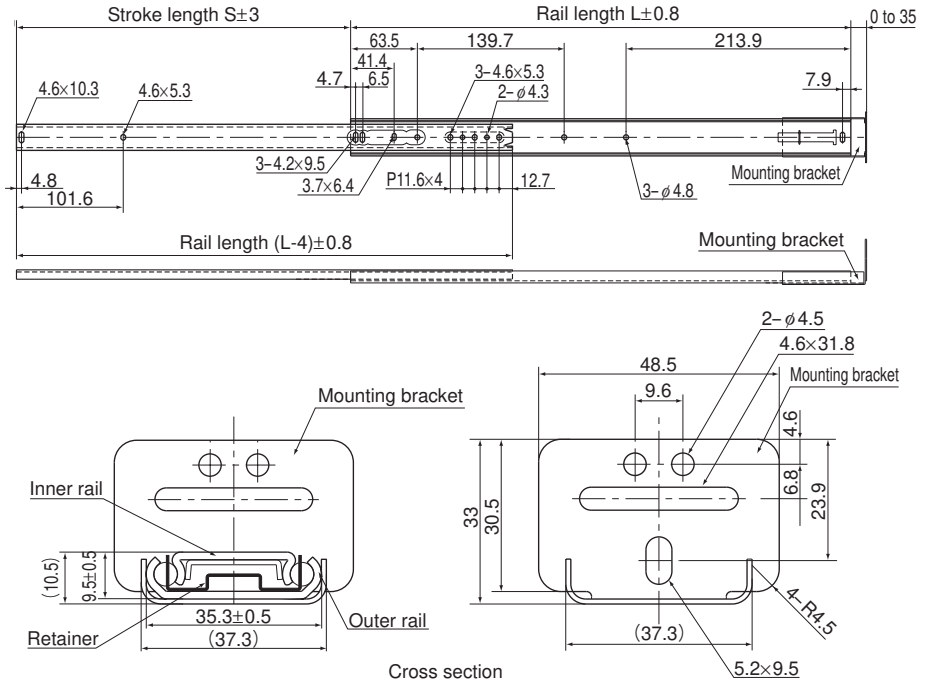

Cross section

Unit: mm

Rail length L (±0.8)	Stroke S (±3)	Mounting hole		Permissible load N/pair	Mass kg/pair
		Inner rail	Outer rail		
324	216	7	7	115	0.8
375	267	7	7	105	0.92
425	305	7	7	100	1
476	318	7	7	90	1.12
527	368	7	7	83	1.24
578	419	7	7	73	1.32
629	445	7	7	66	1.44
679	495	7	7	61	1.6

Note) The permissible load and the mass each indicate the value for a pair of 2 units.

Model number coding

FBL35B +375L

Model number Overall rail length (in mm)

Model FBL 35T

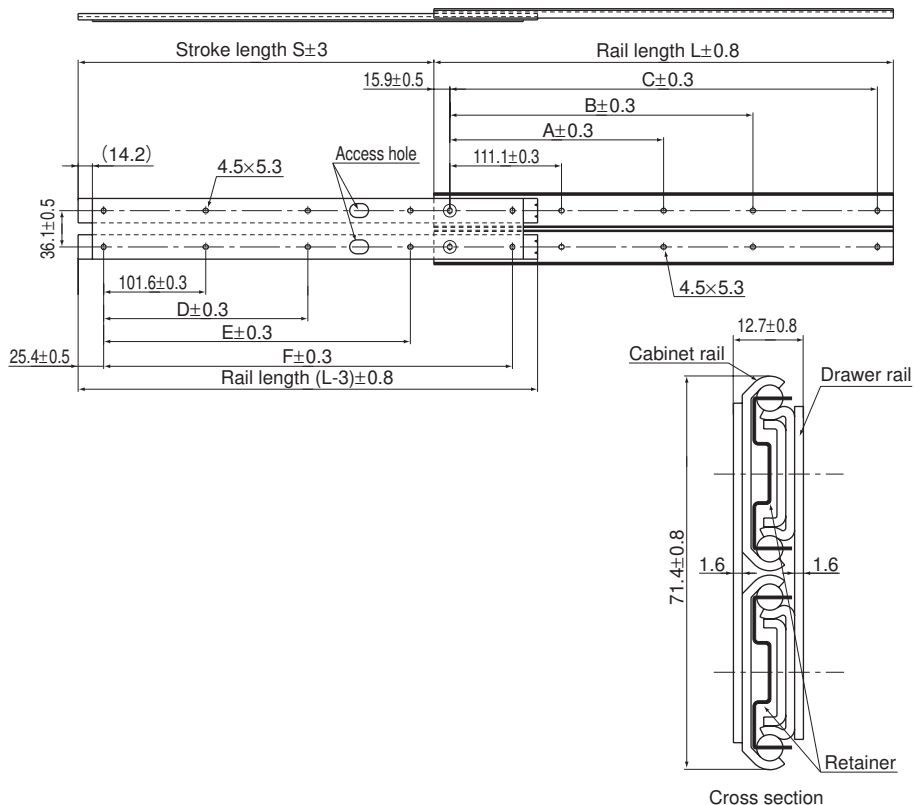

Unit: mm

Rail length L (±0.8)	Stroke S (±3)	Mounting hole dimensions						Mounting hole		Permissible load N/pair	Mass kg/pair
		A	B	C	D	E	F	Inner rail	Outer rail		
305	227	—	149.2	273.0	—	152.8	254.4	4	4	1120	2.16
356	278	—	200.0	323.8	—	203.6	305.2	4	4	1070	2.56
406	303	—	250.8	374.6	—	254.4	356.0	4	4	1020	2.96
457	354	212.7	301.6	425.4	203.2	305.2	406.8	5	5	1000	3.3
508	367	238.1	352.4	476.2	228.6	356.0	457.6	5	5	971	3.64
559	430	263.5	403.2	527.0	254.0	406.8	508.4	5	5	922	4.04
610	456	288.9	454.0	577.8	279.4	457.6	559.2	5	5	873	4.32
660	468	314.3	504.8	628.6	304.8	508.4	610.0	5	5	843	4.72
711	506	339.7	555.6	679.4	330.2	559.2	660.8	5	5	784	5.1

Note) The permissible load and the mass each indicate the value for a pair of 2 units.

Model number coding

FBL35T +559L

Model number Overall rail length (in mm)

Model FBL 27D

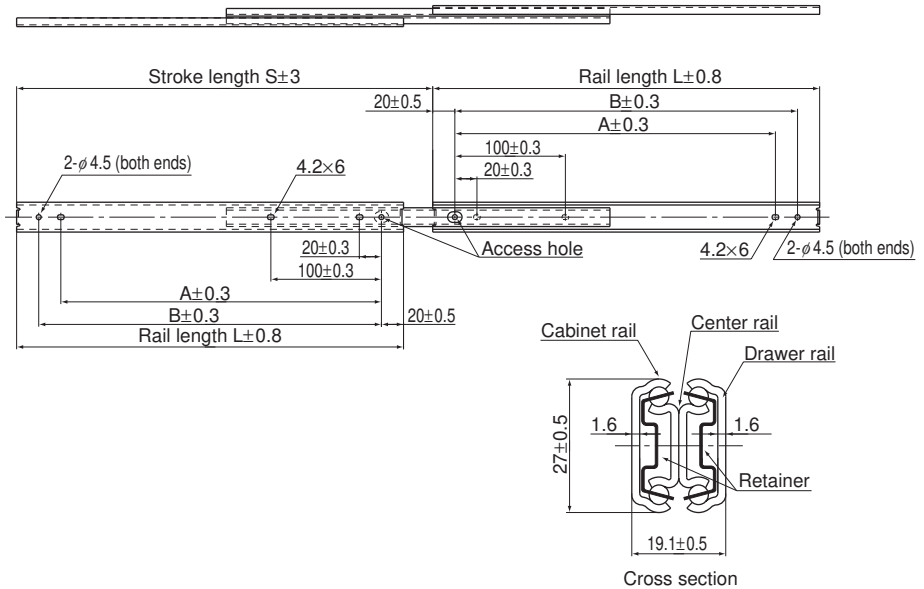

Unit: mm

Rail length L (±0.8)	Stroke S (±3)	Mounting hole dimensions		Mounting hole		Permissible load N/pair	Mass kg/pair
		A	B	Drawer rail	Cabinet rail		
200	229	140.0	160.0	5	5	370	0.64
250	276	190.0	210.0	5	5	360	0.8
300	327	240.0	260.0	5	5	350	0.96
350	376	290.0	310.0	5	5	330	1.12
400	426	340.0	360.0	5	5	310	1.28
450	475	390.0	410.0	5	5	290	1.46
500	524	440.0	460.0	5	5	280	1.6

Note) The permissible load and the mass each indicate the value for a pair of 2 units.

Model number coding

FBL27D +200L

Model number Overall rail length (in mm)

Model FBL 35E-P14

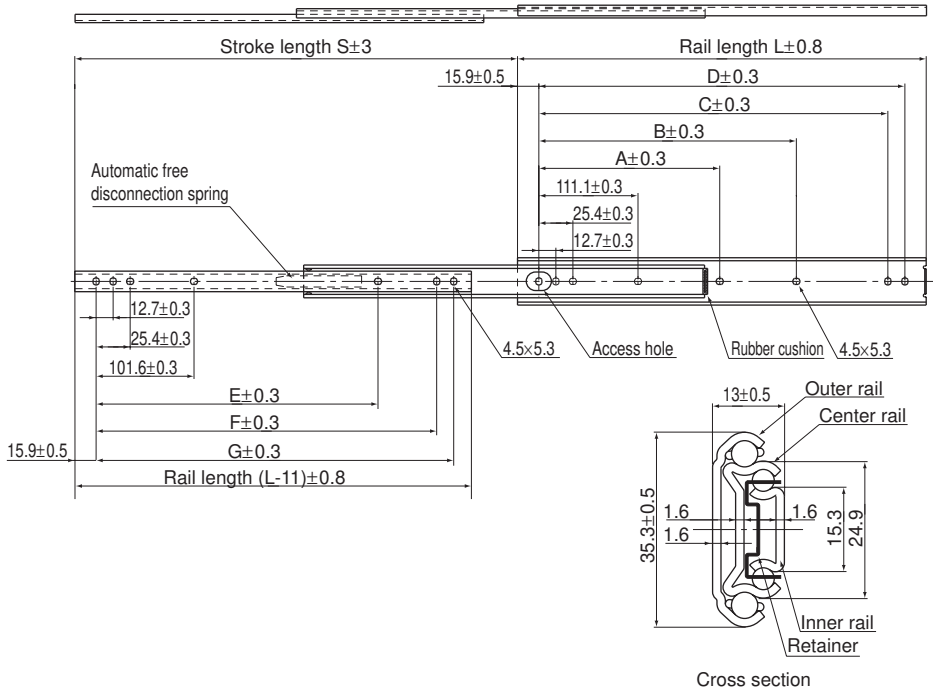

Unit: mm

Rail length L (± 0.8)	Stroke S (± 3)	Mounting hole dimensions							Mounting hole		Permissible load N/pair	Mass kg/pair
		A	B	C	D	E	F	G	Inner rail	Outer rail		
305	330	—	149.2	260.3	273.0	233.1	254.0	266.7	7	7	294	0.88
356	381	—	200.0	311.1	323.8	258.5	304.8	317.5	7	7	284	1.04
406	432	—	250.8	361.9	374.6	283.9	355.6	368.3	7	7	275	1.16
457	483	212.7	301.6	412.7	425.4	309.3	406.4	419.1	7	8	255	1.32
508	533	238.1	352.4	463.5	476.2	334.7	457.2	469.9	7	8	235	1.48

Note) The permissible load and the mass each indicate the value for a pair of 2 units.

Model number coding

FBL35E-P14 +508L

Model number

Overall rail length (in mm)

Model FBL 35G-P13

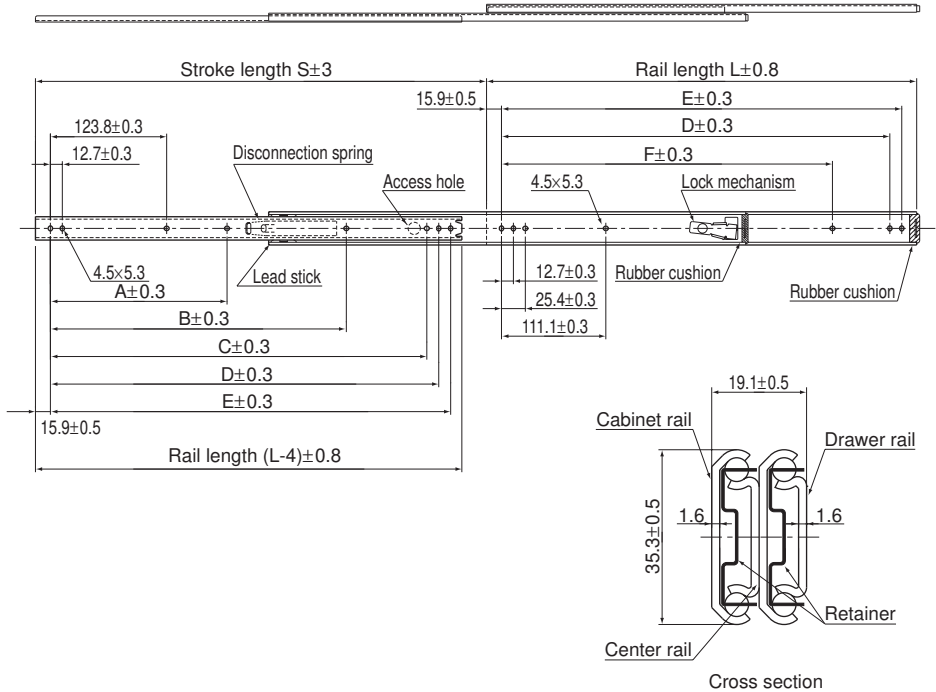

Unit: mm

Rail length L (±0.8)	Stroke S (±3)	Mounting hole dimensions						Mounting hole		Permissible load N/pair	Mass kg/pair
		A	B	C	D	E	F	Drawer rail	Cabinet rail		
305	327	—	—	—	260.3	273.0	—	5	6	623	1.2
356	378	—	—	298.4	311.1	323.8	—	6	6	586	1.4
406	429	—	—	349.2	361.9	374.6	250.8	6	7	555	1.6
457	480	212.7	—	400.0	412.7	425.4	301.6	7	7	516	1.8
508	530	238.1	365.1	450.8	463.5	476.2	352.4	8	7	475	2
559	581	263.5	415.9	501.6	514.3	527.0	403.2	8	7	444	2.2
610	632	288.9	466.7	552.4	565.1	577.8	454.0	8	7	413	2.4
660	683	314.3	517.5	603.2	615.9	628.6	504.8	8	7	382	2.6
711	734	339.7	568.3	654.0	666.7	679.4	555.6	8	7	355	2.8

Note) The permissible load and the mass each indicate the value for a pair of 2 units.

Model number coding

FBL35G-P13 **+356L**

Model number

Overall rail length (in mm)

Model FBL 35G-P14

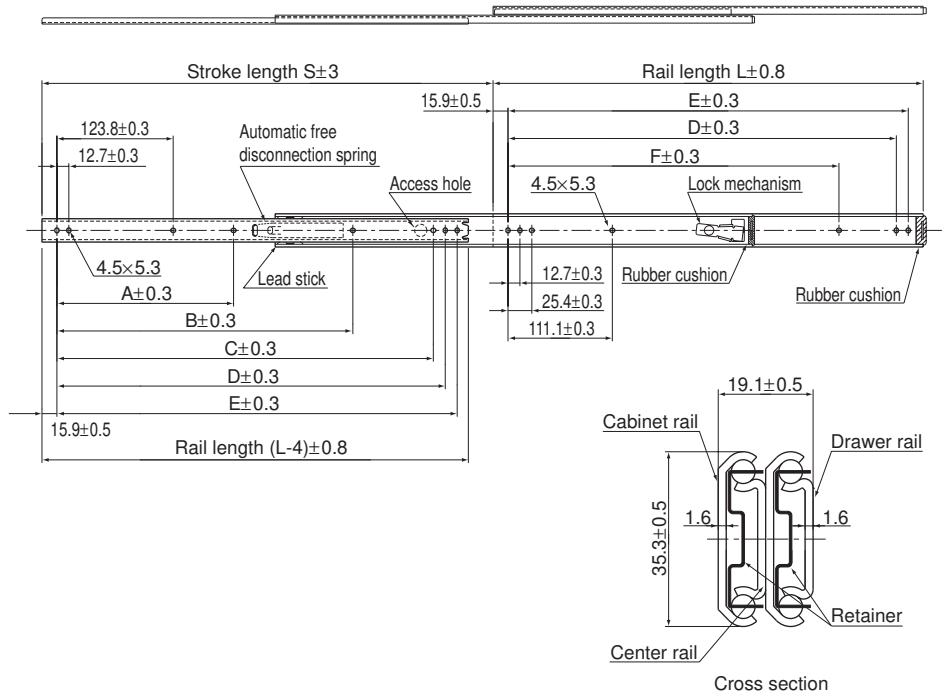

Unit: mm

Rail length L (±0.8)	Stroke S (±3)	Mounting hole dimensions						Mounting hole		Permissible load N/pair	Mass kg/pair
		A	B	C	D	E	F	Drawer rail	Cabinet rail		
305	327	—	—	—	260.3	273.0	—	5	6	623	1.2
356	378	—	—	298.4	311.1	323.8	—	6	6	586	1.4
406	429	—	—	349.2	361.9	374.6	250.8	6	7	555	1.6
457	480	212.7	—	400.0	412.7	425.4	301.6	7	7	516	1.8
508	530	238.1	365.1	450.8	463.5	476.2	352.4	8	7	475	2
559	581	263.5	415.9	501.6	514.3	527.0	403.2	8	7	444	2.2
610	632	288.9	466.7	552.4	565.1	577.8	454.0	8	7	413	2.4
660	683	314.3	517.5	603.2	615.9	628.6	504.8	8	7	382	2.6
711	734	339.7	568.3	654.0	666.7	679.4	555.6	8	7	355	2.8

Note) The permissible load and the mass each indicate the value for a pair of 2 units.

Model number coding

FBL35G-P14 +610L

Model number

Overall rail length (in mm)

Model FBL 35D

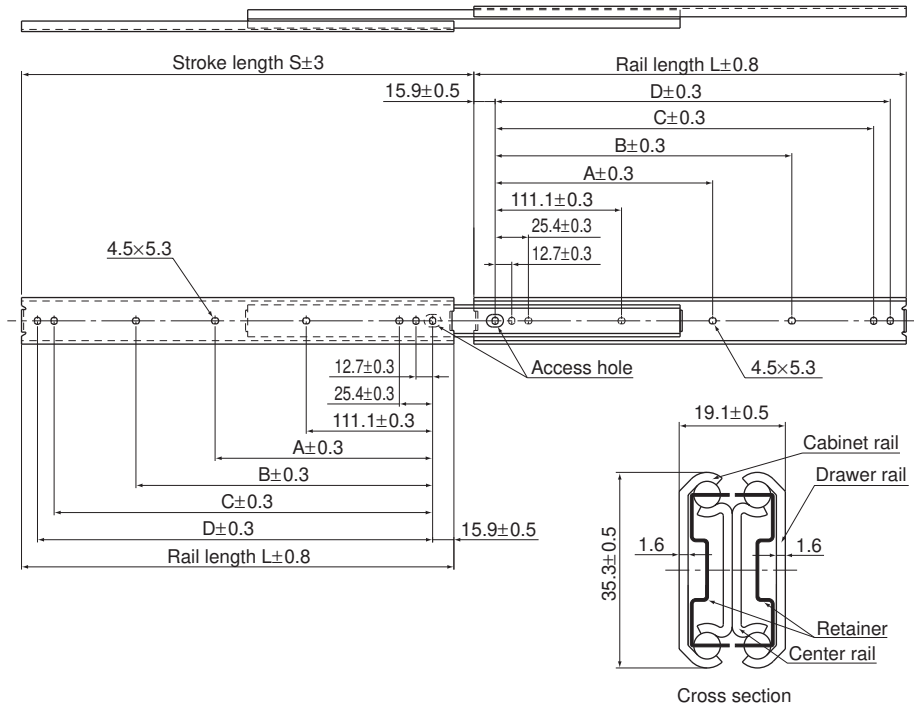

Cross section

Unit: mm

Rail length L (±0.8)	Stroke S (±3)	Mounting hole dimensions				Mounting hole		Permissible load N/pair	Mass kg/pair
		A	B	C	D	Drawer rail	Cabinet rail		
305	327	—	149.2	260.3	273.0	7	7	588	1.28
356	378	—	200.0	311.1	323.8	7	7	578	1.48
406	429	—	250.8	361.9	374.6	7	7	559	1.72
457	480	212.7	301.6	412.7	425.4	8	8	549	1.96
508	530	238.1	352.4	463.5	476.2	8	8	529	2.12
559	581	263.5	403.2	514.3	527.0	8	8	500	2.4
610	632	288.9	454.0	565.1	577.8	8	8	480	2.56
660	683	314.3	504.8	615.9	628.6	8	8	461	2.8
711	734	339.7	555.6	666.7	679.4	8	8	441	3

Note) The permissible load and the mass each indicate the value for a pair of 2 units.

Model number coding

FBL35D +711L

Model number Overall rail length (in mm)

Model FBL 35W

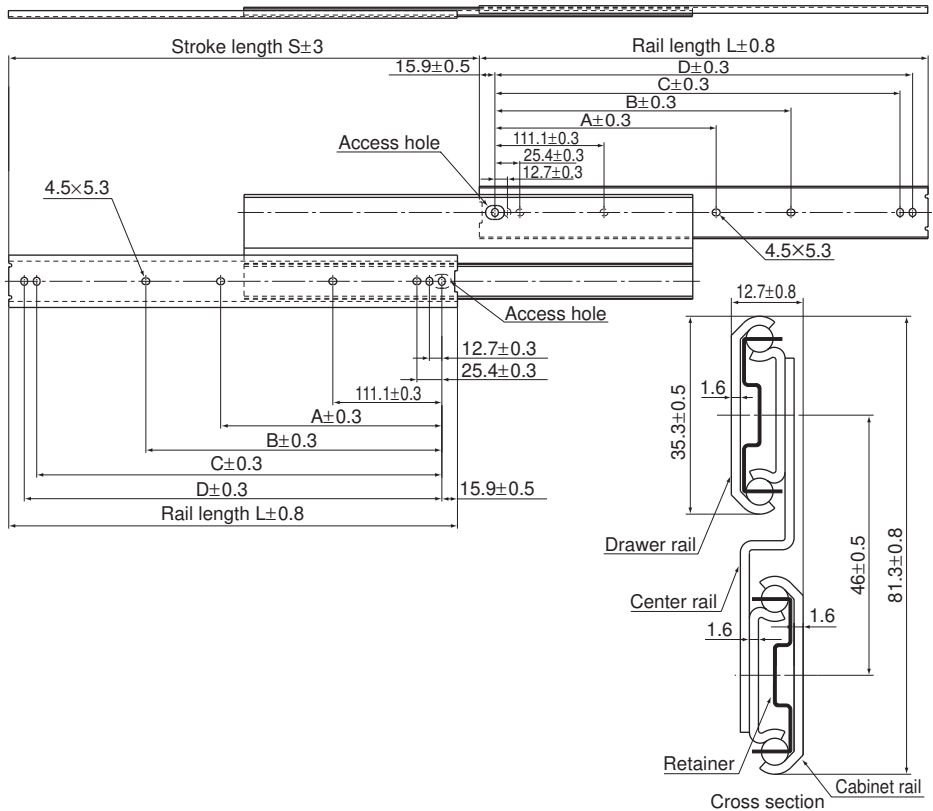

Unit: mm

Rail length L (±0.8)	Stroke S (±3)	Mounting hole dimensions				Mounting hole		Permissible load N/pair	Mass kg/pair
		A	B	C	D	Drawer rail	Cabinet rail		
305	327	—	149.2	260.4	273.1	7	7	706	1.68
356	378	—	200.0	311.2	323.9	7	7	676	2
406	429	—	250.8	362.0	374.7	7	7	637	2.32
457	480	225.4	301.6	412.8	425.5	8	8	598	2.64
508	530	250.8	352.4	463.6	476.3	8	8	569	2.88
559	581	276.2	403.2	514.4	527.1	8	8	520	3.2
610	632	301.6	454.0	565.2	577.9	8	8	480	3.52
660	683	327.0	504.8	616.0	628.7	8	8	422	3.84
711	734	352.4	555.6	666.8	679.5	8	8	353	4.12

Note) The permissible load and the mass each indicate the value for a pair of 2 units.

Model number coding

FBL35W +356L

Model number Overall rail length (in mm)

Model FBL 51H

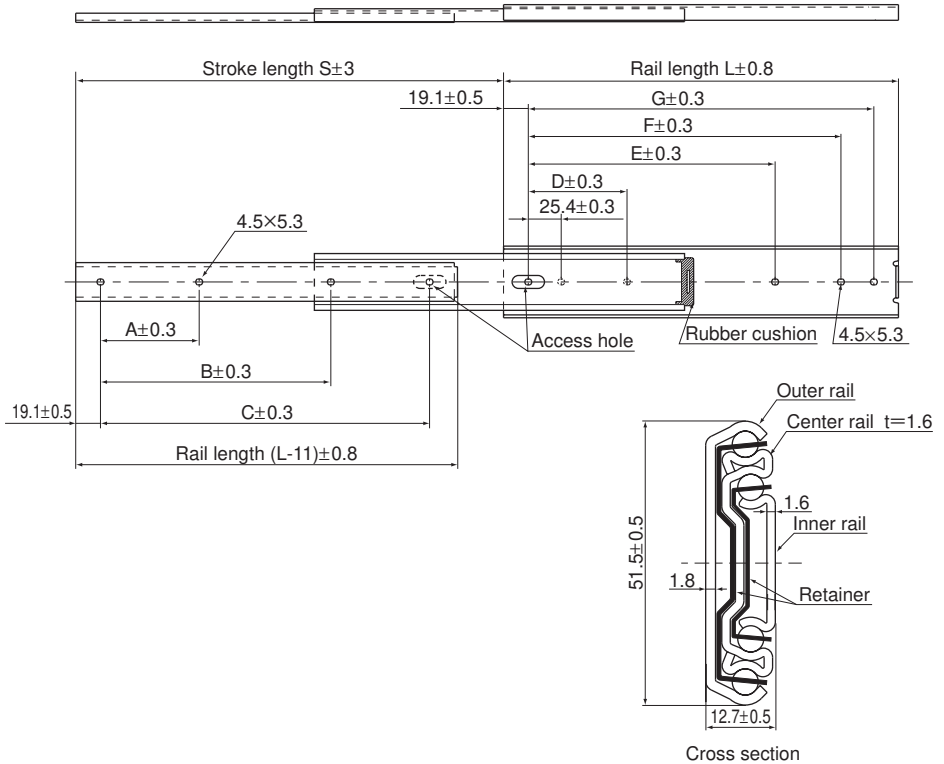

Slide Rail

Unit: mm

Rail length L (±0.8)	Stroke S (±3)	Mounting hole dimensions							Mounting hole		Permissible load N/pair	Mass kg/pair
		A	B	C	D	E	F	G	Inner rail	Outer rail		
305	330	76.2	177.8	254.0	76.2	190.5	241.3	266.7	4	6	850	1.46
356	381	101.6	203.2	304.8	88.9	215.9	292.1	317.5	4	6	820	1.72
406	432	127.0	228.6	355.6	127.0	241.3	342.9	368.3	4	6	770	1.89
457	483	127.0	279.4	406.4	127.0	292.1	393.7	419.1	4	6	730	2.26
508	533	152.4	304.8	457.2	152.4	317.5	444.5	469.9	4	6	710	2.52
559	584	177.8	330.2	508.0	177.8	342.9	495.3	520.7	4	6	690	2.72
610	635	177.8	381.0	558.8	177.8	393.7	546.1	571.5	4	6	660	3.00
660	686	203.2	406.4	609.6	203.2	419.1	596.9	622.3	4	6	630	3.25
711	737	228.6	431.8	660.4	228.6	444.5	647.7	673.1	4	6	610	3.54
762	787	228.6	457.2	711.2	228.6	469.9	698.5	723.9	4	6	580	3.86

Note) The permissible load and the mass each indicate the value for a pair of 2 units.

Model number coding

FBL51H +610L

Model number Overall rail length (in mm)

Model FBL 51H-P13

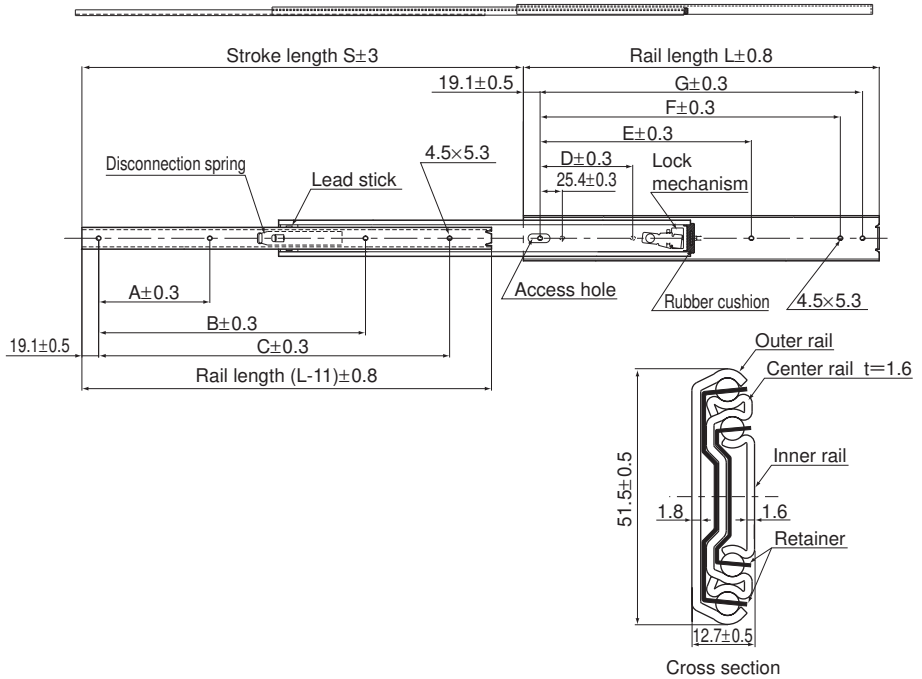

Unit: mm

Rail length L (±0.8)	Stroke S (±3)	Mounting hole dimensions							Mounting hole		Permissible load N/pair	Mass kg/pair
		A	B	C	D	E	F	G	Inner rail	Outer rail		
305	330	76.2	—	190.5	76.2	190.5	241.3	266.7	3	6	850	1.46
356	381	101.6	—	266.7	88.9	215.9	292.1	317.5	3	6	820	1.72
406	432	127.0	—	304.8	127.0	241.3	342.9	368.3	3	6	770	1.89
457	483	127.0	317.5	368.3	127.0	292.1	393.7	419.1	4	6	730	2.26
508	533	152.4	355.6	406.4	152.4	317.5	444.5	469.9	4	6	710	2.52
559	584	177.8	381.0	457.2	177.8	342.9	495.3	520.7	4	6	690	2.72
610	635	177.8	430.8	508.0	177.8	393.7	546.1	571.5	4	6	660	3.00
660	686	203.2	457.2	558.8	203.2	419.1	596.9	622.3	4	6	630	3.25
711	737	228.6	508.0	609.6	228.6	444.5	647.7	673.1	4	6	610	3.54
762	787	228.6	533.4	660.4	228.6	469.9	698.5	723.9	4	6	580	3.86

Note) The permissible load and the mass each indicate the value for a pair of 2 units.

Model number coding

FBL51H-P13 +559L

Model number

Overall rail length (in mm)

Model FBL 51H-P14

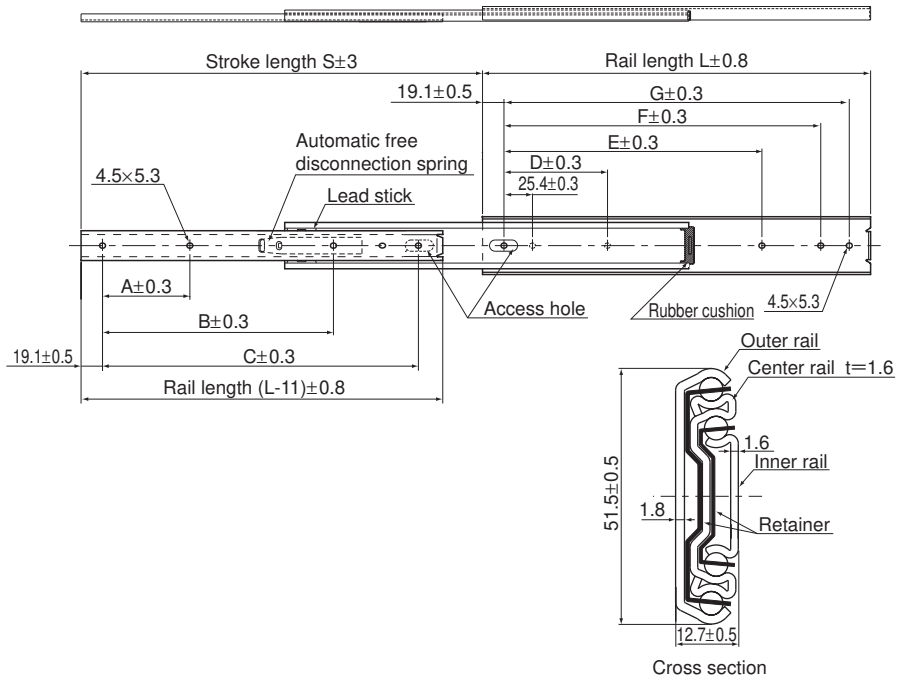

Unit: mm

Rail length L (±0.8)	Stroke S (±3)	Mounting hole dimensions							Mounting hole		Permissible load N/pair	Mass kg/pair
		A	B	C	D	E	F	G	Inner rail	Outer rail		
305	330	76.2	—	254.0	76.2	190.5	241.3	266.7	3	6	850	1.46
356	381	127.0	—	304.8	88.9	215.9	292.1	317.5	3	6	820	1.72
406	432	152.4	317.5	355.6	127.0	241.3	342.9	368.3	4	6	770	1.89
457	483	177.8	368.3	406.4	127.0	292.1	393.7	419.1	4	6	730	2.26
508	533	152.4	419.1	457.2	152.4	317.5	444.5	469.9	4	6	710	2.52
559	584	177.8	469.9	508.0	177.8	342.9	495.3	520.7	4	6	690	2.72
610	635	177.8	520.7	558.8	177.8	393.7	546.1	571.5	4	6	660	3.00
660	686	203.2	571.5	609.6	203.2	419.1	596.9	622.3	4	6	630	3.25
711	737	228.6	622.3	660.4	228.6	444.5	647.7	673.1	4	6	610	3.54
762	787	228.6	673.1	711.2	228.6	469.9	698.5	723.9	4	6	580	3.86

Note) The permissible load and the mass each indicate the value for a pair of 2 units.

Model number coding

FBL51H-P14 +305L

Model number

Overall rail length (in mm)

Model FBL 35K

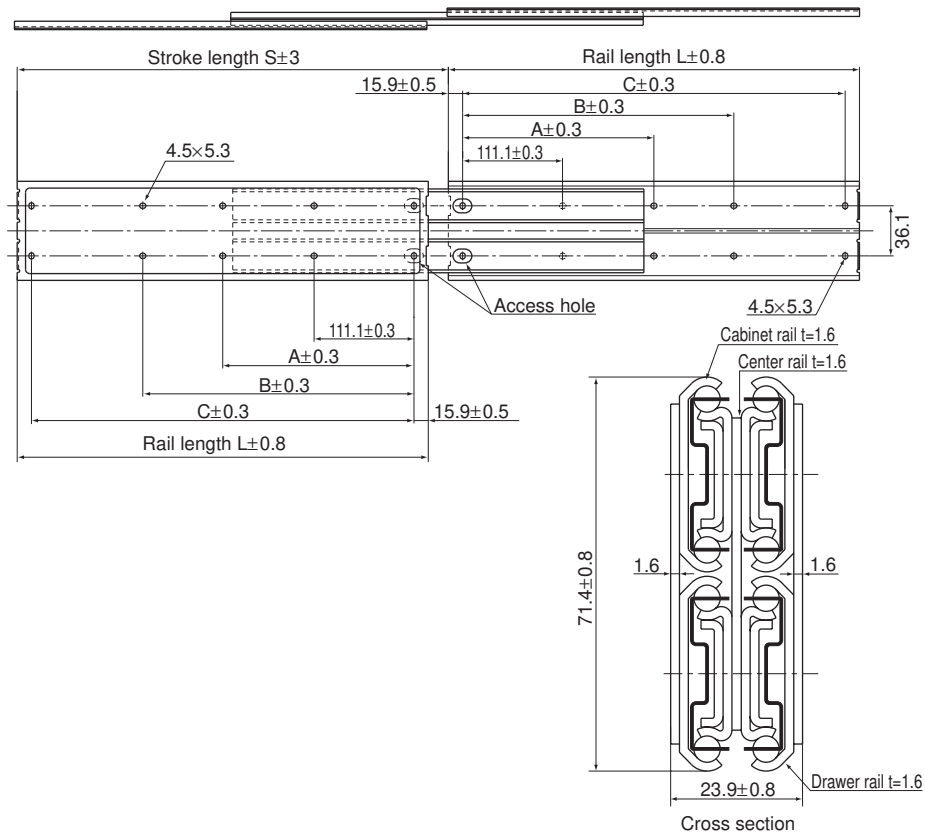

Unit: mm

Rail length L (±0.8)	Stroke S (±3)	Mounting hole dimensions			Mounting hole		Permissible load N/pair	Mass kg/pair
		A	B	C	Drawer rail	Cabinet rail		
305	327	—	149.2	273.0	4	4	2670	4.04
356	378	—	200.0	323.8	4	4	2630	4.8
406	429	—	250.8	374.6	4	4	2540	5.6
457	480	212.7	301.6	425.4	5	5	2450	6.04
508	530	238.1	352.4	476.2	5	5	2360	6.92
559	581	263.5	403.2	527.0	5	5	2250	7.56
610	632	288.9	454.0	577.8	5	5	2120	8.4
660	683	314.3	504.8	628.6	5	5	1960	9
711	734	339.7	555.6	679.4	5	5	1780	9.68

Note) The permissible load and the mass each indicate the value for a pair of 2 units.

Model number coding

FBL35K +711L

Model number Overall rail length (in mm)

Model FBL 56H

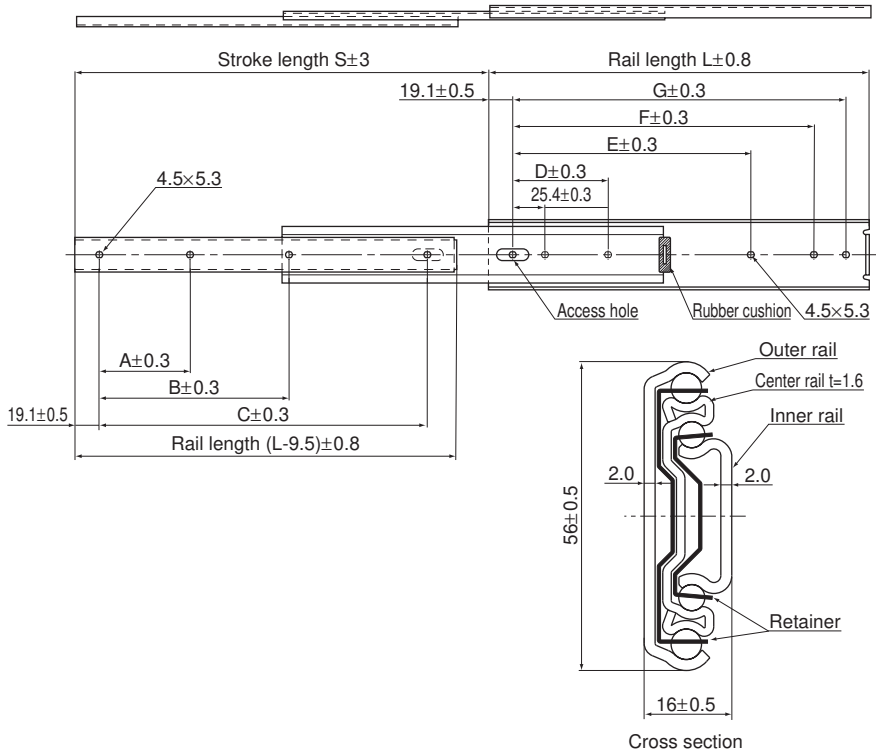

Unit: mm

Rail length L (±0.8)	Stroke S (±3)	Mounting hole dimensions						Mounting hole		Permissible load N/pair	Mass kg/pair	
		A	B	C	D	E	F	G	Inner rail			Outer rail
305	330	76.2	177.8	254.0	76.2	190.5	241.3	266.7	4	6	961	1.76
356	381	101.6	203.2	304.8	88.9	215.9	292.1	317.5	4	6	951	2.04
406	432	127.0	228.6	355.6	127.0	241.3	342.9	368.3	4	6	941	2.36
457	483	127.0	279.4	406.4	127.0	292.1	393.7	419.1	4	6	922	2.64
508	533	152.4	304.8	457.2	152.4	317.5	444.5	469.9	4	6	902	2.96
559	584	177.8	330.2	508.0	177.8	342.9	495.3	520.7	4	6	882	3.24
610	635	177.8	381.0	558.8	177.8	393.7	546.1	571.5	4	6	863	3.6
660	686	203.2	406.4	609.6	203.2	419.1	596.9	622.3	4	6	843	3.84
711	737	228.6	431.8	660.4	228.6	444.5	647.7	673.1	4	6	824	4.06
762	787	228.6	457.2	711.2	228.6	469.9	698.5	723.9	4	6	784	4.44

Note) The permissible load and the mass each indicate the value for a pair of 2 units.

Model number coding

FBL56H +406L

Model number Overall rail length (in mm)

Model FBL 56H-P13

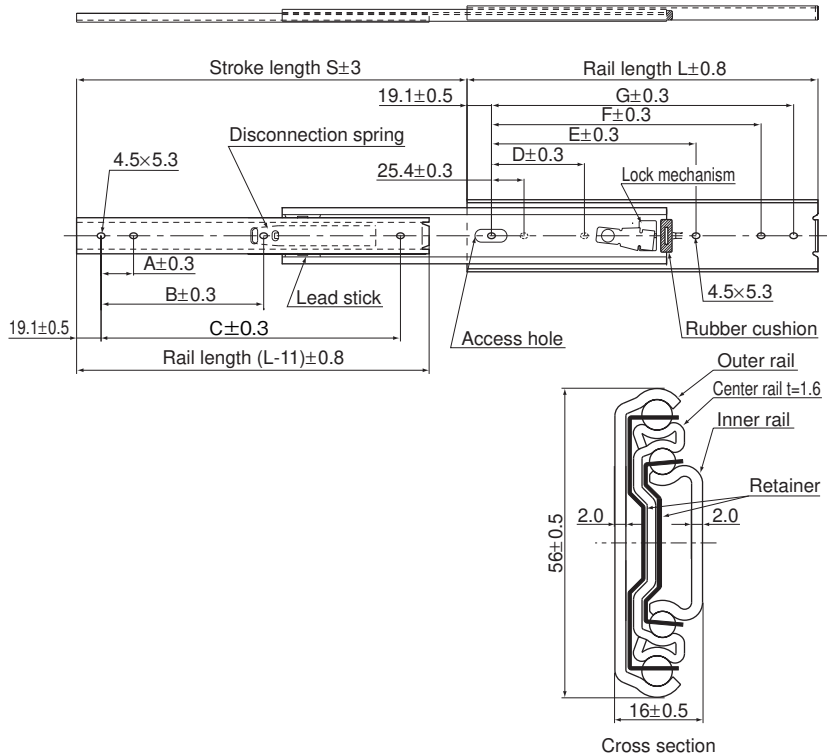

Unit: mm

Rail length L (±0.8)	Stroke S (±3)	Mounting hole dimensions						Mounting hole		Permissible load N/pair	Mass kg/pair	
		A	B	C	D	E	F	G	Inner rail			Outer rail
305	330	76.2	—	254.0	76.2	190.5	241.3	266.7	3	6	961	1.76
356	381	127.0	—	304.8	88.9	215.9	292.1	317.5	3	6	951	2.04
406	432	152.4	317.5	355.6	127.0	241.3	342.9	368.3	4	6	941	2.36
457	483	177.8	368.3	406.4	127.0	292.1	393.7	419.1	4	6	922	2.64
508	533	152.4	419.1	457.2	152.4	317.5	444.5	469.9	4	6	902	2.96
559	584	177.8	469.9	508.0	177.8	342.9	495.3	520.7	4	6	882	3.24
610	635	177.8	520.7	558.8	177.8	393.7	546.1	571.5	4	6	863	3.6
660	686	203.2	571.5	609.6	203.2	419.1	596.9	622.3	4	6	843	3.84
711	737	228.6	622.3	660.4	228.6	444.5	647.7	673.1	4	6	824	4.06
762	787	228.6	673.1	711.2	228.6	469.9	698.5	723.9	4	6	784	4.44

Note) The permissible load and the mass each indicate the value for a pair of 2 units.

Model number coding

FBL56H-P13 +762L

Model number

Overall rail length (in mm)

Model FBL 56H-P14

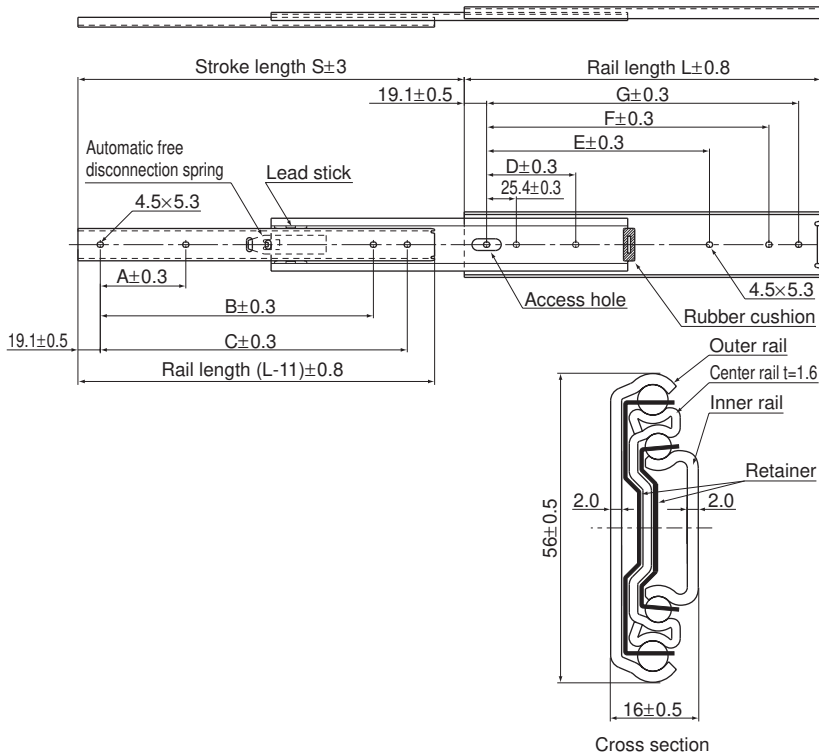

Unit: mm

Rail length L (±0.8)	Stroke S (±3)	Mounting hole dimensions							Mounting hole		Permissible load N/pair	Mass kg/pair
		A	B	C	D	E	F	G	Inner rail	Outer rail		
305	330	76.2	—	254.0	76.2	190.5	241.3	266.7	3	6	961	1.76
356	381	127.0	—	304.8	88.9	215.9	292.1	317.5	3	6	951	2.04
406	432	152.4	317.5	355.6	127.0	241.3	342.9	368.3	4	6	941	2.36
457	483	177.8	368.3	406.4	127.0	292.1	393.7	419.1	4	6	922	2.64
508	533	152.4	419.1	457.2	152.4	317.5	444.5	469.9	4	6	902	2.96
559	584	177.8	469.9	508.0	177.8	342.9	495.3	520.7	4	6	882	3.24
610	635	177.8	520.7	558.8	177.8	393.7	546.1	571.5	4	6	863	3.6
660	686	203.2	571.5	609.6	203.2	419.1	596.9	622.3	4	6	843	3.84
711	737	228.6	622.3	660.4	228.6	444.5	647.7	673.1	4	6	824	4.06
762	787	228.6	673.1	711.2	228.6	469.9	698.5	723.9	4	6	784	4.44

Note) The permissible load and the mass each indicate the value for a pair of 2 units.

Model number coding

FBL56H-P14 +457L

Model number

Overall rail length (in mm)

Model FBL 35F

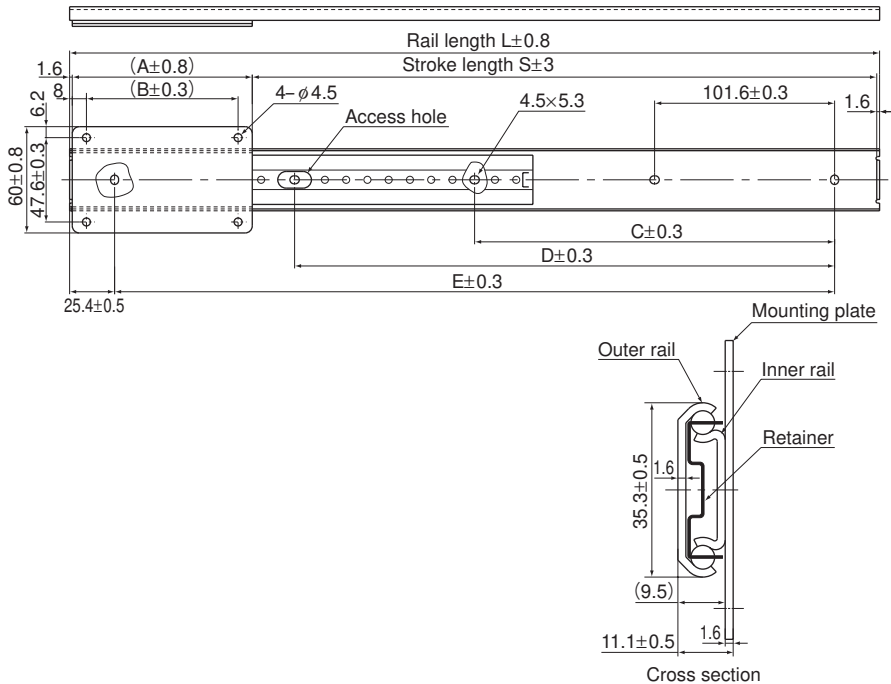

Unit: mm

Mounting plate	Model No.	#3	#4	#5	#6	#7	#8	Dimension of the outer rail mounting hole (± 0.3)		
	Length (A ± 0.8)	76.2	101.6	127	152.4	177.8	203.2	C	D	E
Rail length L(± 0.8)		Stroke length S (± 3) * Varies with the combination with the mounting plate above.						C	D	E
305		225.4	200.0	174.6	149.2	—	—	—	152.4	254.0
356		276.2	250.8	225.4	200.0	174.6	149.2	—	203.2	304.8
406		327.0	301.6	276.2	250.8	225.4	200.0	—	254.0	355.6
457		377.8	352.4	327.0	301.6	276.2	250.8	203.2	304.8	406.4
508		428.6	403.2	377.8	352.4	327.0	301.6	228.6	355.6	457.2
559		479.4	454.0	428.6	403.2	377.8	352.4	254.0	406.4	508.0
610		530.2	504.8	479.4	454.0	428.6	403.2	279.4	457.2	558.8
660		581.0	555.6	530.2	504.8	479.4	454.0	304.8	508.0	609.6
711		631.8	606.4	581.0	555.6	530.2	504.8	330.2	558.8	660.4
762		682.6	657.2	631.8	606.4	581.0	555.6	355.6	609.6	711.2
Pitch of the mounting plate mounting hole (B ± 0.3)		60.2	85.6	111.0	136.4	161.8	187.2	—	—	—
Permissible load (N/pair)		294	392	490	588	686	784	—	—	—

Note) The permissible load indicates the value for a pair of 2 units.

Model number coding

FBL35F +356L #5

Model number

Model number of mounting plate

Overall rail length (in mm)

Model FBL 56F

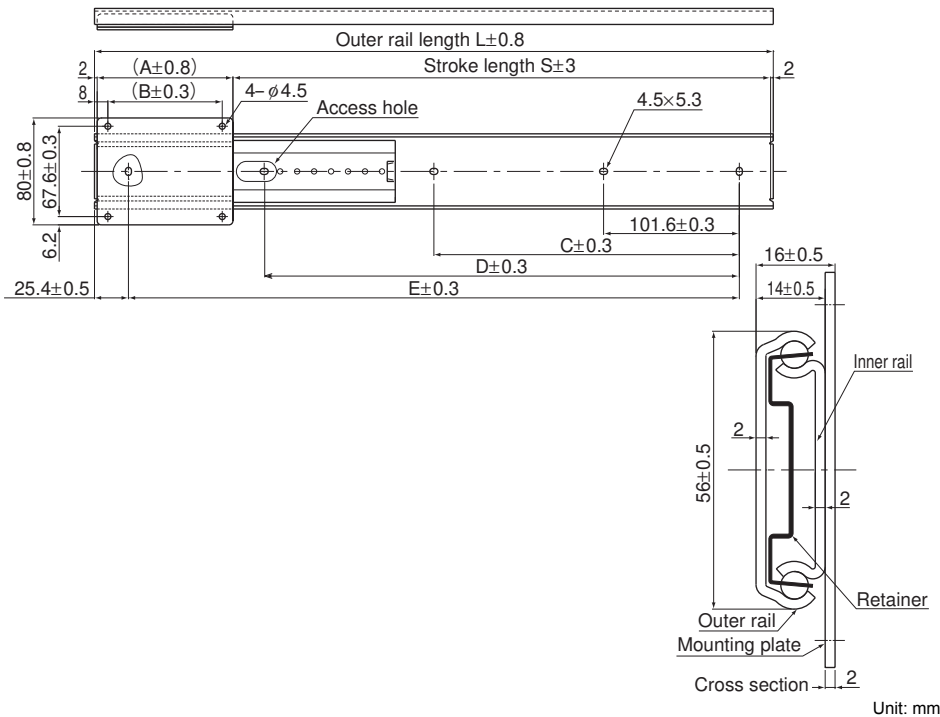

Unit: mm

Mounting plate	Model No.	#3	#4	#5	#6	#7	#8	Dimension of the outer rail mounting hole (±0.3)		
	Length (A±0.8)	76.2	101.6	127	152.4	177.8	203.2	C	D	E
	Rail length L(±0.8)	Stroke length S (±3) * Varies with the combination with the mounting plate above.						C	D	E
	305	224.6	199.2	173.8	148.4	—	—	—	152.4	254.0
	356	275.4	250.0	224.6	199.2	173.8	148.4	—	203.2	304.8
	406	326.2	300.8	275.4	250.0	224.6	199.2	—	254.0	355.6
	457	377.0	351.6	326.2	300.8	275.4	250.0	203.2	304.8	406.4
	508	427.8	402.4	377.0	351.6	326.2	300.8	228.6	355.6	457.2
	559	478.6	453.2	427.8	402.4	377.0	351.6	254.0	406.4	508.0
	610	529.4	504.0	478.6	453.2	427.8	402.4	279.4	457.2	558.8
	660	580.2	554.8	529.4	504.0	478.6	453.2	304.8	508.0	609.6
	711	631.0	605.6	580.2	554.8	529.4	504.0	330.2	558.8	660.4
	762	681.8	656.4	631.0	605.6	580.2	554.8	355.6	609.6	711.2
	Pitch of the mounting plate mounting hole (B±0.3)	60.2	85.6	111.0	136.4	161.8	187.2	—	—	—
	Permissible load (N/pair)	588	784	980	1176	1372	1568	—	—	—

Note) The permissible load indicates the value for a pair of 2 units.

Model number coding

FBL56F +305L #6

Model number

Model number of mounting plate

Overall rail length (in mm)

Model FBL 48DR

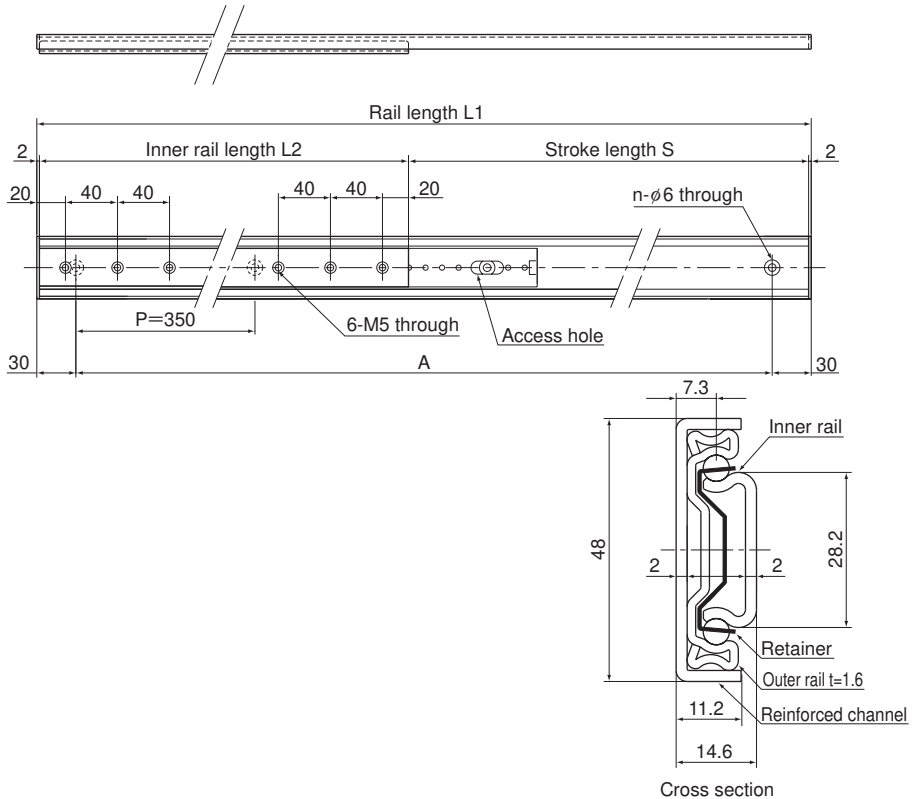

Unit: mm

Outer rail length L_1	Inner rail length L_2	Stroke length S	Mounting hole pitch A	No. of mounting holes n
1110	496	610	P350×3	4
1110	696	410	P350×3	4
1460	496	960	P350×4	5
1460	696	760	P350×4	5
1810	696	1110	P350×5	6
2160	496	1660	P350×6	7
2160	696	1460	P350×6	7

Model number coding

FBL48DR +1810L

Model number

Overall rail length (in mm)

Model E15

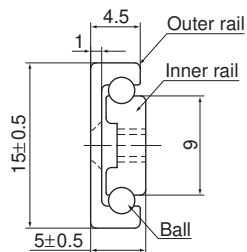
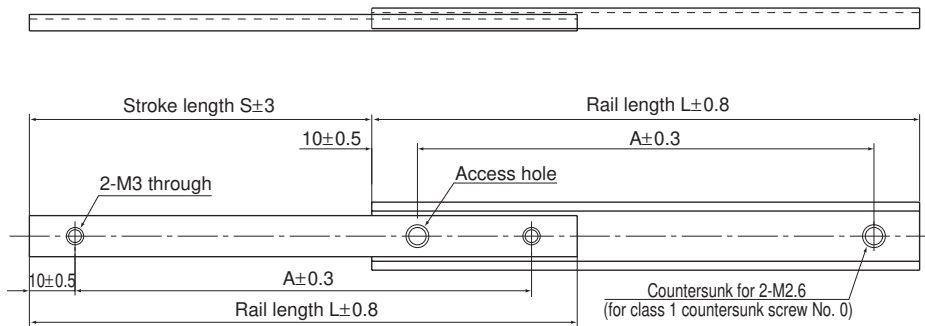

Cross section

Unit: mm

Rail length $L (\pm 0.8)$	Stroke $S (\pm 3)$	Mounting hole dimensions $A \pm 0.3$	Permissible load N/pair
50	20	30.0	5
80	45	60.0	8
100	60	80.0	10
120	75	100.0	10

Note) The permissible load indicates the value for a pair of 2 units.

Model number coding

E15 +100L

Model number Overall rail length (in mm)

Model E20

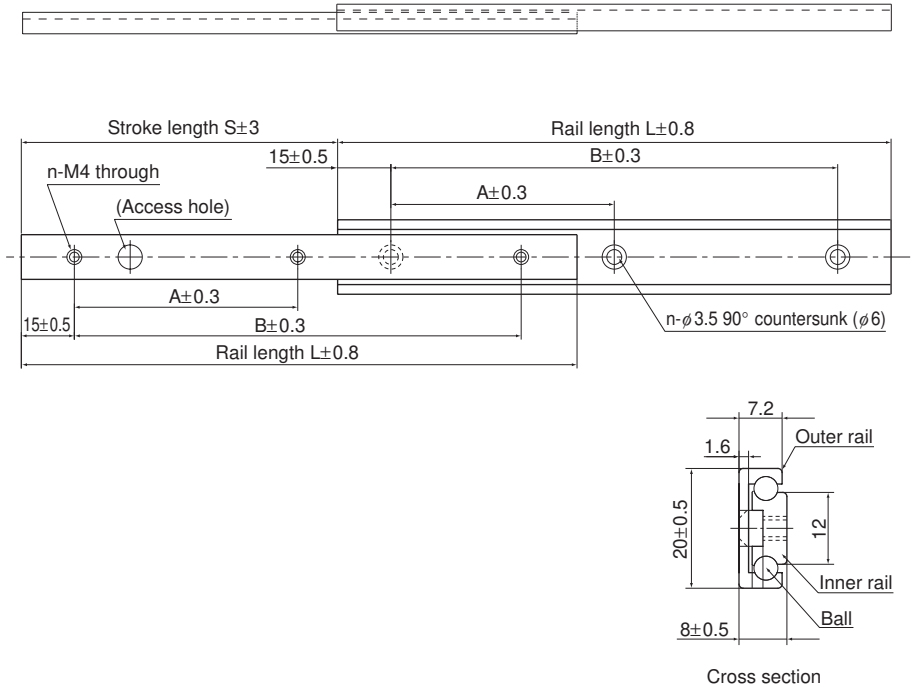

Unit: mm

Rail length L (± 0.8)	Stroke S (± 3)	Mounting hole dimensions			Permissible load N/pair
		A ± 0.3	B ± 0.3	n (pcs)	
80	45	50.0	—	2	20
100	60	70.0	—	2	30
150	85	60.0	120.0	3	80
200	120	85.0	170.0	3	140
300	180	135.0	270.0	3	145

Note) The permissible load indicates the value for a pair of 2 units.

Model number coding

E20 +150L

Model number Overall rail length (in mm)

Model D20

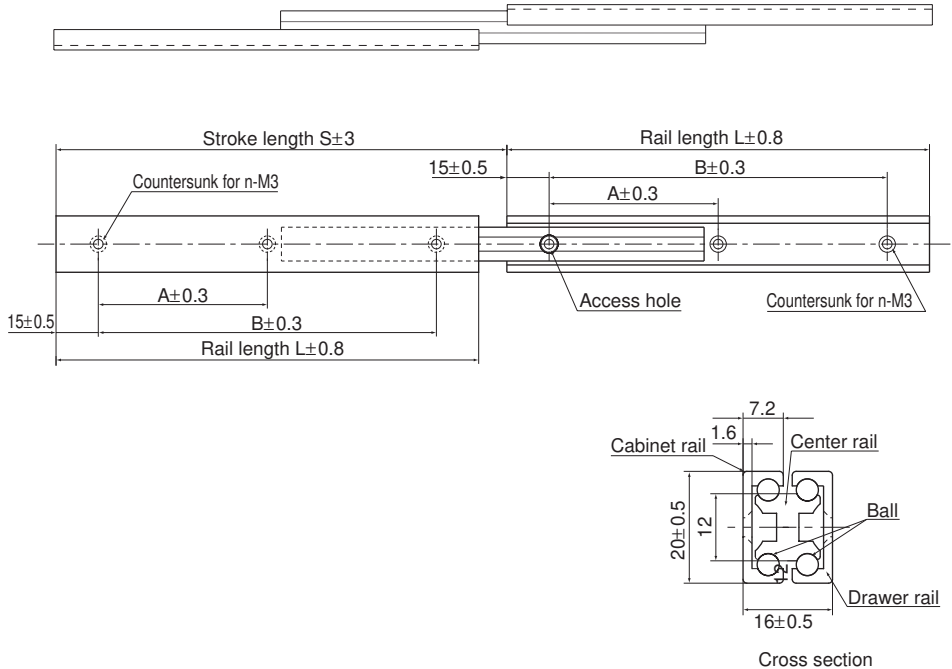

Unit: mm

Rail length L (±0.8)	Stroke S (±3)	Mounting hole dimensions			Permissible load N/pair
		A±0.3	B±0.3	n (pcs)	
80	80	50.0	—	2	20
100	100	70.0	—	2	30
150	160	60.0	120.0	3	80
200	223	85.0	170.0	3	140
300	345	135.0	270.0	3	145

Note) The permissible load indicates the value for a pair of 2 units.

Model number coding

D20 +300L

Model number Overall rail length (in mm)