

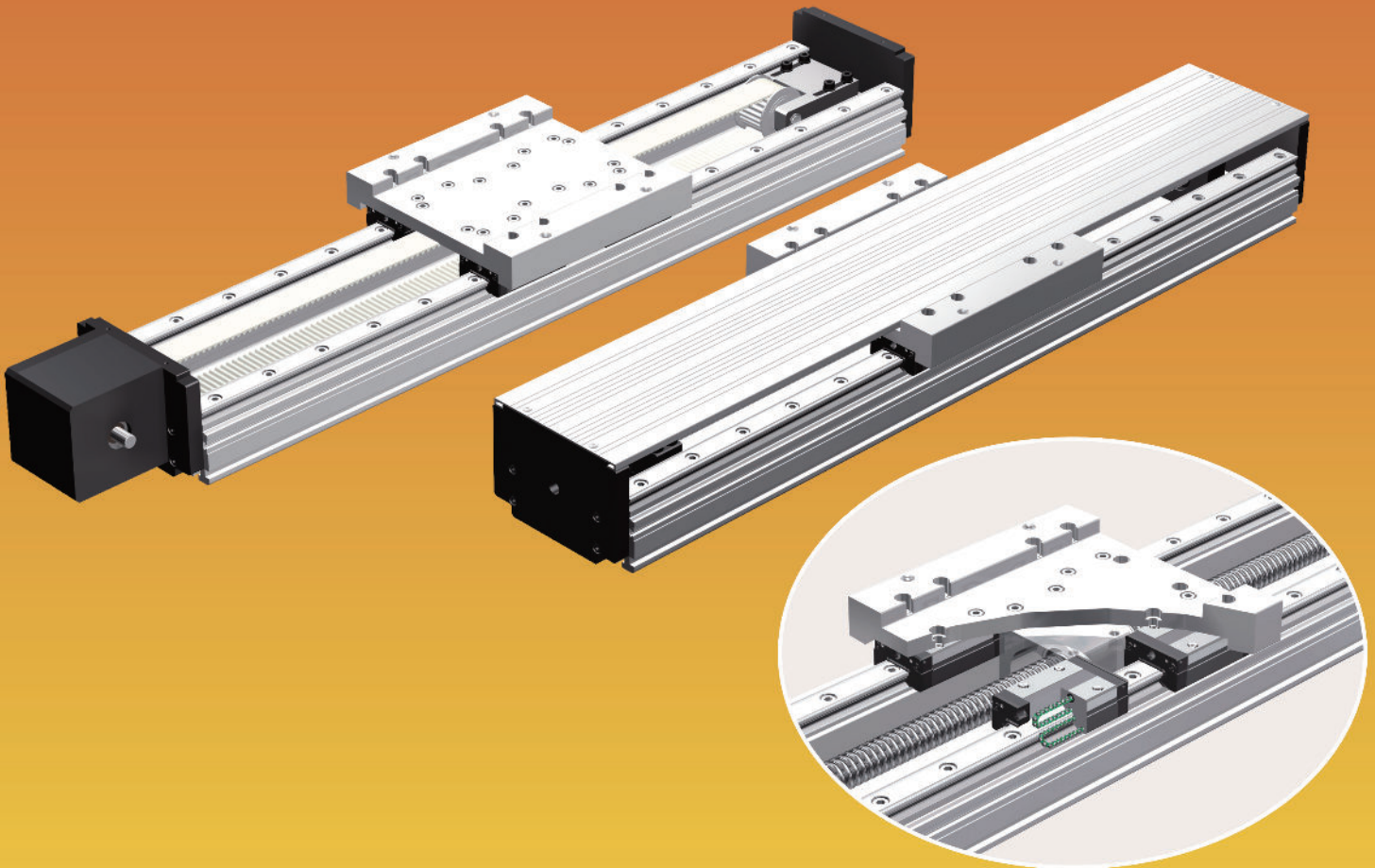

LM Actuator

Equipped with Caged Ball
LM Guides and QZ Lubricator
for Ball Screw

GL-N



For details, visit THK at www.thk.com

*Product information is updated regularly on the THK website.

THK CO., LTD.
TOKYO, JAPAN

CATALOG No. 177-3E

Structures of LM Actuator GL-N Model

Ball Screw

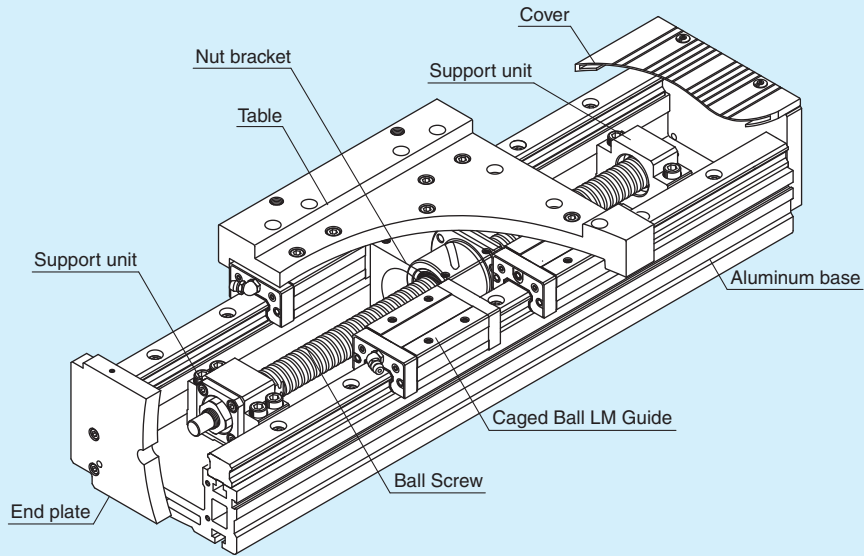

Figure 1 Ball Screw Type Structure

Timing Belt

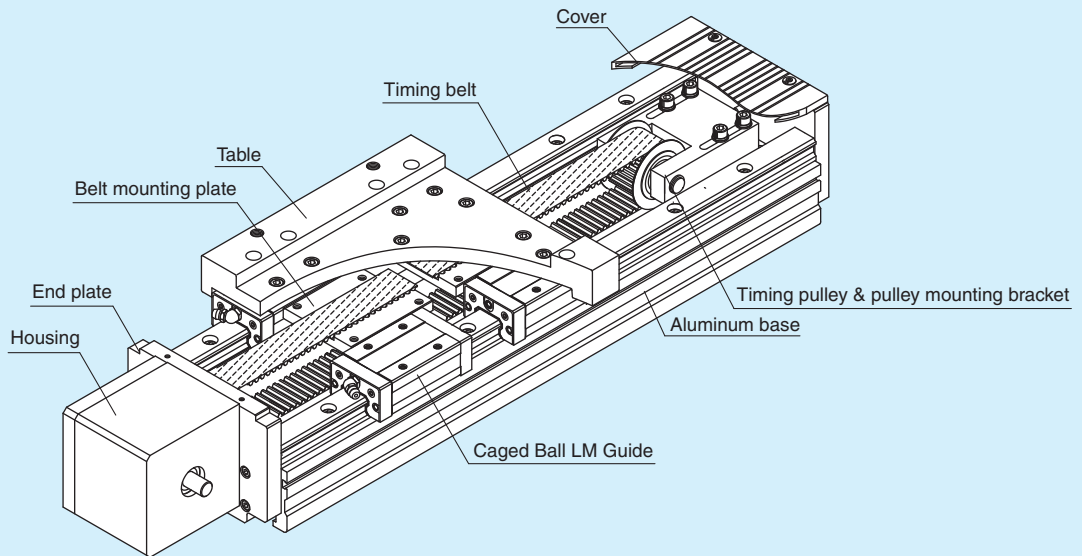

Figure 2 Timing Belt Type Structure

Features of LM Actuator GL-N Model

Lightweight, high rigidity aluminum base with Caged Ball LM Guides has been utilized for the guide portion. A screw or belt options are available for the drive system.

In addition, Caged Ball LM Guides and QZ Lubricator for the Ball Screw has been utilized to provide a long-term maintenance free actuator.

Utilizing Caged Ball LM Guide (SSR, SHS)

SSR model: Due to its 90-degree ball contact structure, is best suited to horizontal applications with relatively low moment loads.

SHS model: It can handle loads from all directions (radial, reverse radial, and horizontal) with its 4-way equal load rating capability.

Drive System

[Ball Screw Type]

Variety of screw leads can be selected.

Table 1 Ball Screw Leads by Model Numbers (Rolled ball screw)

Model number	Ball Screw lead (mm)
GL15N	5, 10, 16, 20, 30
GL20N	5, 10, 20, 40

Note: For wrap-around motor types, three motor directions (left, right and bottom) can be selected. (See page 4 for details.)

[Timing Belt Type]

Highly rigid timing belt ensures that high speed processes are possible for longer stroke (max. 2720 mm) applications than the Ball Screw driven type.

Table 2 Pitch Diameter of the Timing Pulley

Model number	Pitch diameter (mm)	Slider move distance per pulley rotation (mm)
GL15N	35.01	$35.01 \times \pi \approx 110$
GL20N	38.20	$38.20 \times \pi \approx 120$

Note: Because the timing pulley has a large pitch diameter, the use of a reducer is recommended. For details, see pages 18 and 19.

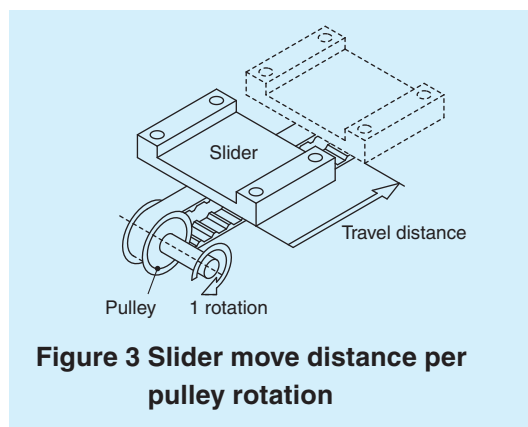

Figure 3 Slider move distance per pulley rotation

Lightweight and High Rigidity

By using a hollow aluminum extrusion, lightweight and high rigidity is achieved.

Table 3 Geometrical Moment of Inertia and Weight in the Base

Model number	Geometrical Moment of Inertia		Weight (kg/m)
	I_x (mm ⁴)	I_y (mm ⁴)	
GL15N	1.61×10^5	2.47×10^6	4.85
GL20N	3.15×10^5	4.28×10^6	6.47*

* The weight of the SSR model is 6.69kg/m.

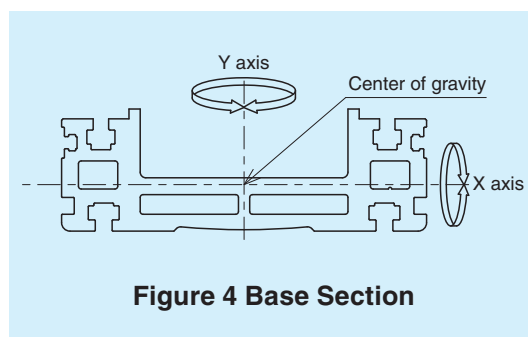

Figure 4 Base Section

GL-N Model also available with optional QZ Lubricator

A Caged Ball LM Guide and QZ Lubricator for the Ball Screw have been utilized to ensure a long-term maintenance-free actuator.

Ensuring Adaptability with Most Advanced Motors

A wide variety of end plates (motor mounting plates, motor brackets, reducers) are available to be attached to motors with the latest control technologies. As well as, motors with features applicable for Model GL-N. (See pages 16 to 19.)

Multiple Options Available

Multiple options such as covers, bellows, sensors and cable carriers are available.

Height Dimensions Standardized with Model GL

With the same height dimensions as Model GL using the conventional full-ball type Model GSR, replacing with the maintenance-free actuator Model GL-N using Caged Ball LM Guide is possible.

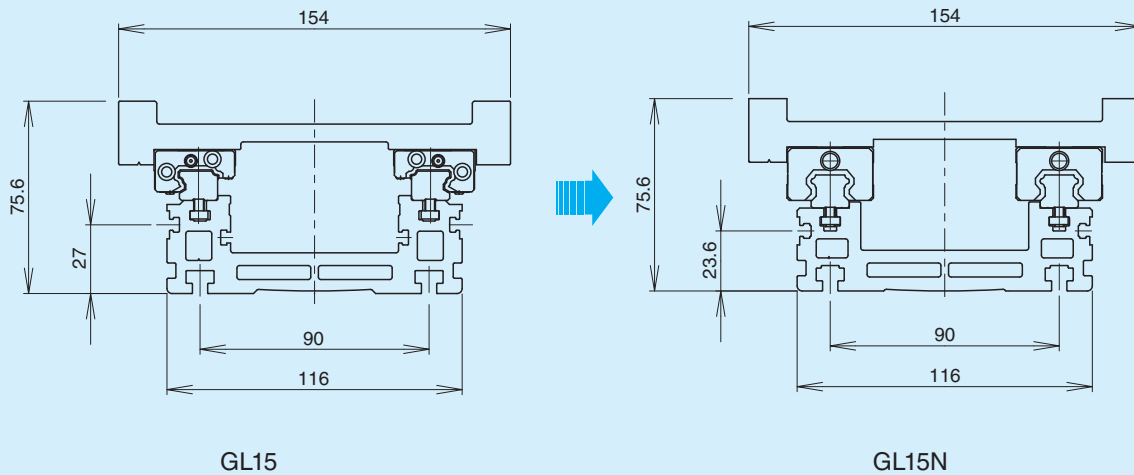

Figure 5 Cross-section comparative views

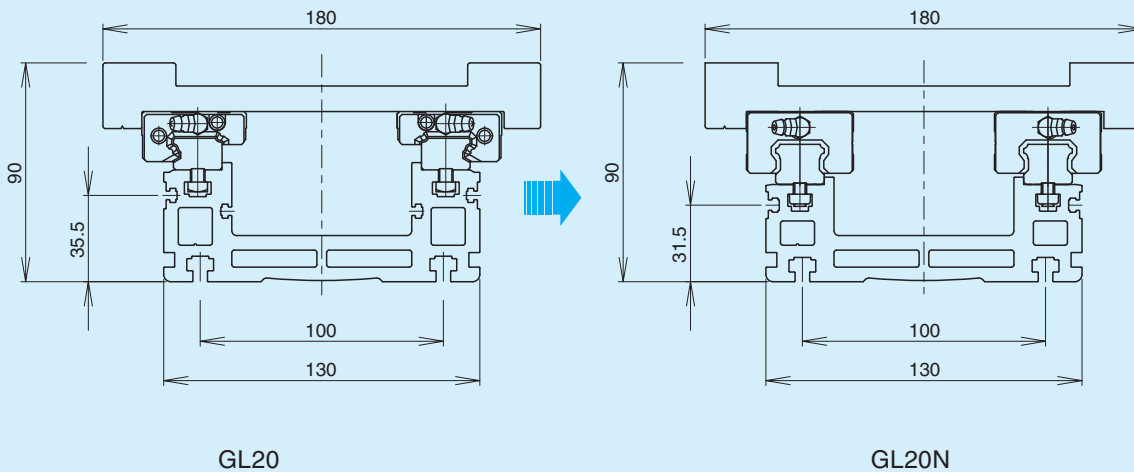

Figure 6 Cross-section comparative views

Types and Features

Types of Drive Systems

[Ball Screw Drive]

Direct Mounting

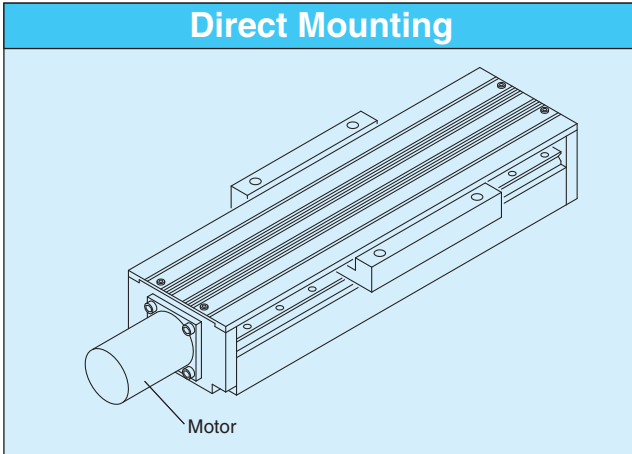

Requires Servo Coupling to connect the ball screw shaft with input motor shaft.

Lateral wrap-around Option

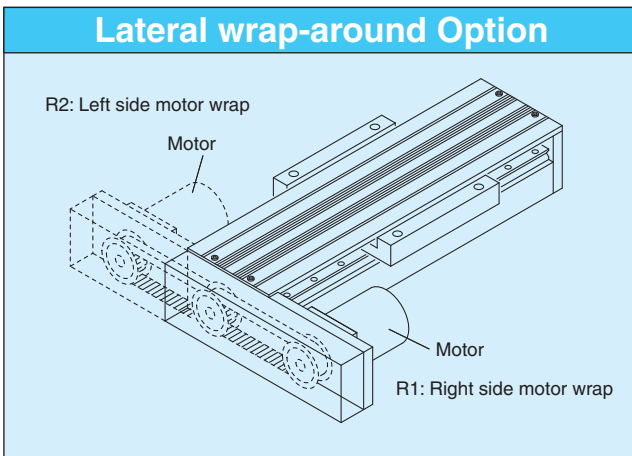

Axial dimensions are kept to minimum by applying the Wrap-Around option.
(Pulley ratio: 1:1)

Bottom wrap-around Option

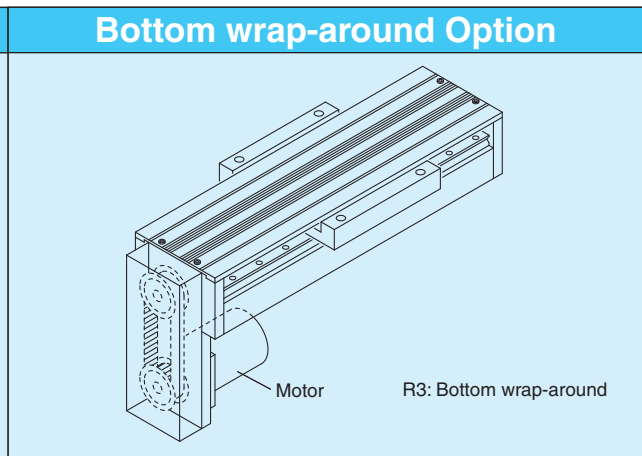

When horizontal space is at a minimum, the bottom side Wrap-Around option is available.
(Pulley ratio: 1:1)

[Timing Belt Type]

Horizontal Mounting

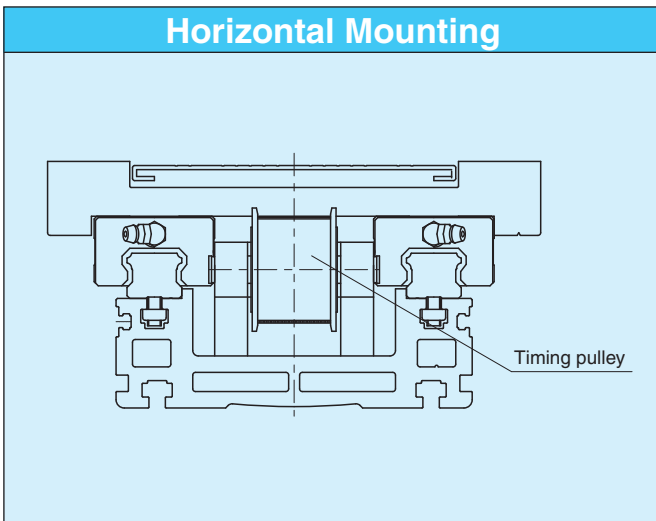

Note 1: Please mount Model GL-N horizontally. Contact THK if Model GL-N will be mounted on a wall.

Note 2: Please note that Model GL-N with timing belts cannot be mounted vertically.

Specification

Model number		GL15N						GL20N					
Drive system		Ball Screw						Belt					
Screw lead (mm)		5	10	16	20	30	-						
Pulley pitch diameter (mm)		-						35.01					
Repeatability ^{Note 1)} (mm)		±0.02						±0.08					
Effective stroke ^{Note 2)} (mm)		100 to 1200						50 to 1700					
Maximum load capacity guideline ^{Note 3) Note 4)} [kg]	200W	Horizontal	60	60	50	45	20	30					
		Vertical	20	16	10	10	3	-					
	400W	Horizontal	-	-	-	-	-	70					
		Vertical	-	-	-	-	-	30					
Static permissible load ^{Note 5)} [N]	Reverse radial direction	9600						14300					
	Horizontal direction	2900						4500					
	Axial direction	2100						-					
Static permissible moment ^{Note 6)} [N-m]	M _A	430						710					
	M _B	240						430					
	M _C	610						1020					

Note 1: This repeatability is ensured at an ambient temperature of 20°C.

Note 2: The effective stroke decreases depending on the table length. See the dimensional drawings (pages 7 to 14) for stroke details.

Note 3: Maximum load capacity guideline is determined based on rated revolution of the motor at the acceleration of 0.3G.

The motor capacity assumes the use of an AC servomotor.

Note 4: Values for the belt drive type are guidelines when using 1/5 reducers.

Note 5: The static permissible load is determined by the bolt joint strength, and the static rated load of the LM guide unit, ball screw unit and the support bearing.

For safety purposes, please take into consideration that the strength of the actuator mounting unit is not included.

Note 6: The static permissible moment is the maximum value of the moment in each direction.

For details on fatigue life, see "Service Life Time and Static Safety Factor" on pages 25 to 26.

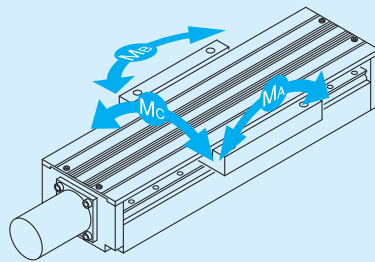

M_A : Pitching direction

M_B : Yawing direction

M_C : Rolling direction

Figure 7 Directions of static permissible moment

Types of Tables

S type: Short table (applicable LM Guide model number: SSR-XV)

A short table length ensures a longer stroke.

L type: Long table (applicable LM Guide model number: SSR-XW, and SHS-V)

This table is suitable for mounting large sized objects or if the load is off center.

L-QZ type: Long table with an LM Guide QZ Lubricator (applicable LM Guide model numbers: SSR-XWQZ and SHS-VQZ)

The LM Guide is provided with a QZ Lubricator. (This table is longer than the L-type table. See dimensional drawings for more details.)

Maximum Travel Speed of the LM Actuator

Ball Screw Type

Ball Screws have an allowable rotational speed based on the DN value and the critical speed.

The table travel speed (mm/s) of the LM Actuator depends on the rotational speed of the Ball Screw and the rated rpm (3000 min⁻¹) of the AC servo motor.

Maximum travel speed

Unit: mm/s

Nominal model number		GL15N						GL20N			
Ball Screw lead		5	10	16	20	30	5	10	20	40	
Base length	340	248	500	800	1000	1500	-	-	-	-	
	460	248	500	800	1000	1500	202	500	1000	2000	
	580	248	500	800	1000	1500	202	500	1000	2000	
	700	248	500	800	1000	1500	202	500	1000	2000	
	820	248	500	800	1000	1500	202	500	1000	2000	
	1060	207	391	685	776	1175	202	396	1000	2000	
	1240	144	271	474	540	815	185	275	763	1533	
	1420	105	198	349	396	595	136	201	560	1120	
	1600	-	-	-	-	-	104	-	426	860	
	1780	-	-	-	-	-	82	-	336	673	

Note: The LM actuator may not reach the maximum travel speed if the moving distance is short.

Timing Belt Type

The table shown below summarizes the table travel speed (mm/s) of when the LM Actuator is equipped with a reducer and the AC servo motor is operated at a rated rpm (3000min⁻¹).

Maximum travel speed

Unit: mm/s

Nominal model number		GL15N			GL20N		
Reduction ratio		1/3	1/5	1/9	1/3	1/5	1/9
Maximum travel speed		1833	1100	611	2000	1200	667

Ball Screw Driven Dimensions

GL15N Model, Ball Screw Driven

[Direct Mounting Specification]

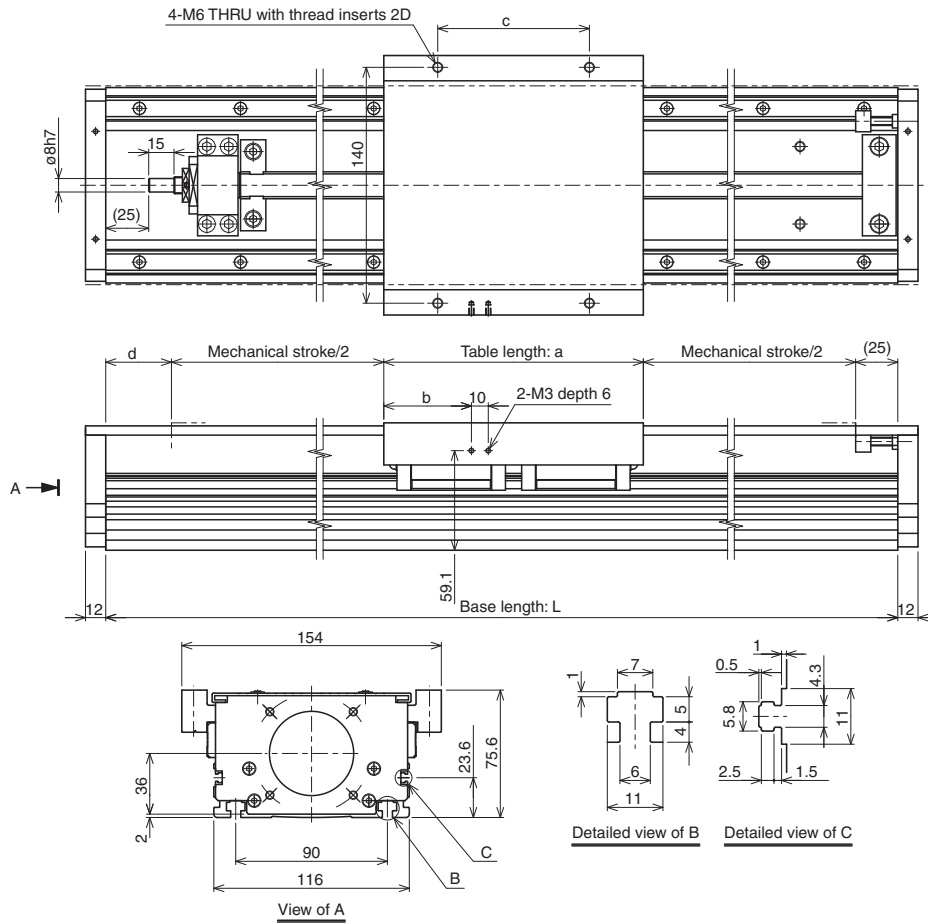

Unit: mm

Table type	Table length: a	b	c	d
S type	126	38	90	53
L type	154	52	90	39
L(QZ) type	154	52	90	48
L-QZ type	180	65	120	21

Base length: L [mm]		340	460	580	700	820	1060	1240	1420	
Mechanical stroke [mm]	Table	S type	136	256	376	496	616	856	1036	1216
		L type	122	242	362	482	602	842	1022	1202
		L(QZ) type	113	233	353	473	593	833	1013	1193
		L-QZ type	114	234	354	474	594	834	1014	1194
Main unit weight [kg]	Table	S type	5.8	6.9	8.0	9.2	10.3	12.5	14.2	15.9
		L type (SSR15XW)	6.1	7.2	8.3	9.5	10.6	12.8	14.5	16.2
		L type (SHS15V)	6.5	7.6	8.8	9.9	11.1	13.4	15.1	16.8

Note 1: The main unit weight includes the cover weight.

Note 2: The table L(QZ) type shows a QZ specification only for the Ball Screw.

Note 3: The main unit weight of the QZ type is the main unit weight of the table +0.1kg.

[Lateral Wrap-around Specification]

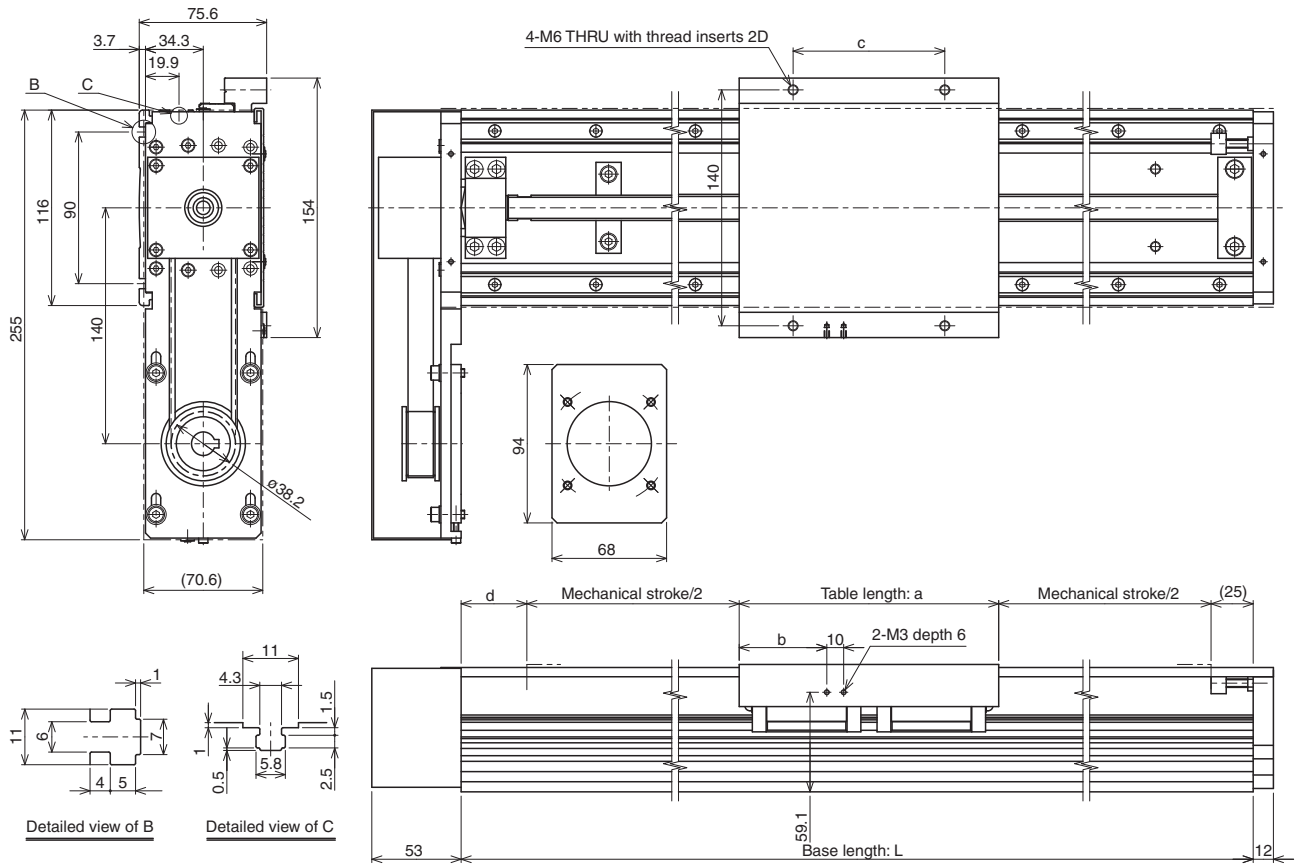

Unit: mm

Table type	Table length: a	b	c	d
S type	126	38	90	53
L type	154	52	90	39
L(QZ) type	154	52	90	48
L-QZ type	180	65	120	21

Base length: L [mm]		340	460	580	700	820	1060	1240	1420	
Mechanical stroke [mm]	Table	S type	136	256	376	496	616	856	1036	1216
		L type	122	242	362	482	602	842	1022	1202
		L(QZ) type	113	233	353	473	593	833	1013	1193
		L-QZ type	114	234	354	474	594	834	1014	1194
Main unit weight [kg]	Table	S type	7.4	8.5	9.6	10.8	11.9	14.1	15.8	17.5
		L type (SSR15XW)	7.7	8.8	9.9	11.1	12.2	14.4	16.1	17.8
		L type (SHS15V)	8.1	9.2	10.4	11.5	12.7	15.0	16.7	18.4

Note 1: The main unit weight includes the cover weight.

Note 2: The table L(QZ) type shows a QZ specification only for the Ball Screw.

Note 3: The main unit weight of the QZ type is the main unit weight of the table +0.1kg.

[Bottom Wrap-around Specification]

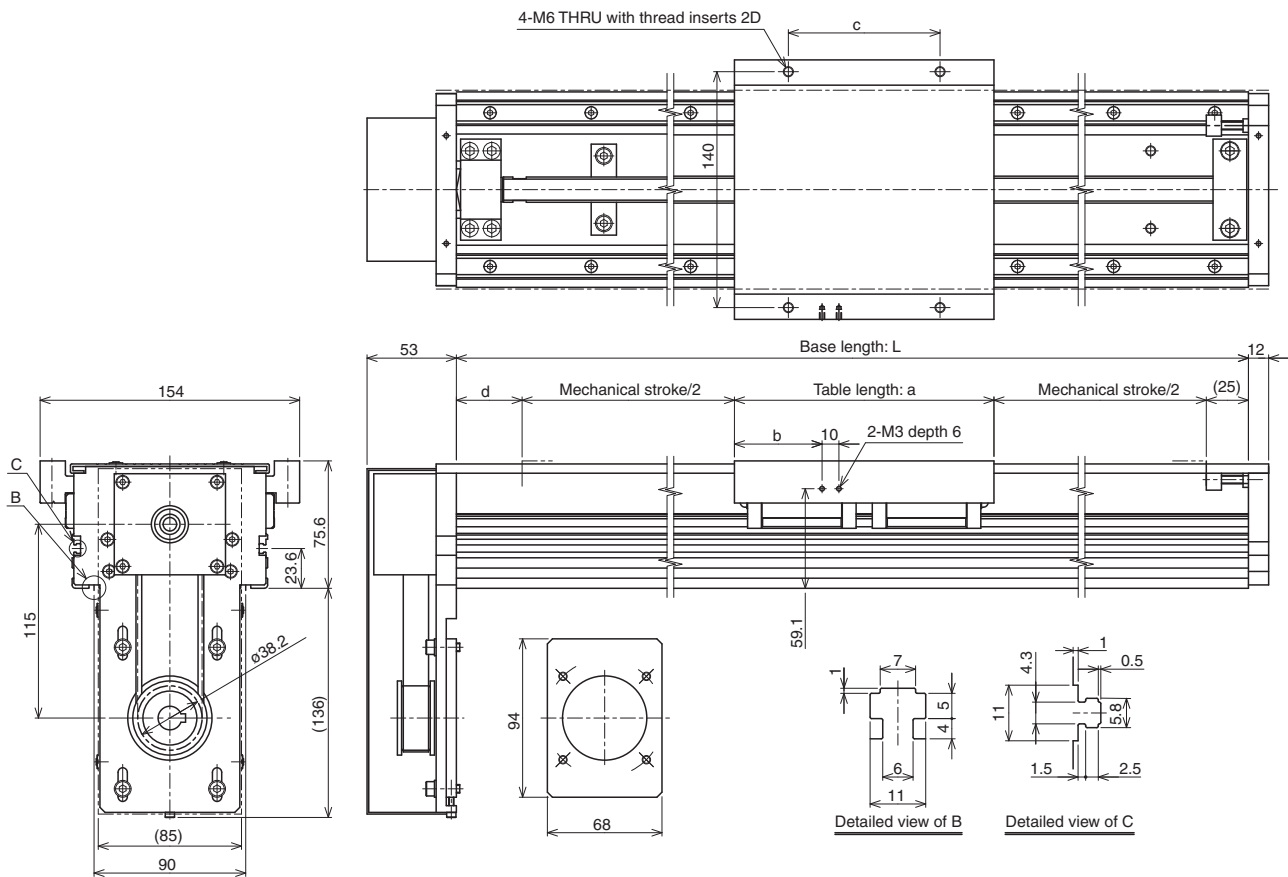

Unit: mm

Table type	Table length: a	b	c	d
S type	126	38	90	53
L type	154	52	90	39
L(QZ) type	154	52	90	48
L-QZ type	180	65	120	21

Base length: L [mm]		340	460	580	700	820	1060	1240	1420	
Mechanical stroke [mm]	Table	S type	136	256	376	496	616	856	1036	1216
		L type	122	242	362	482	602	842	1022	1202
		L(QZ) type	113	233	353	473	593	833	1013	1193
		L-QZ type	114	234	354	474	594	834	1014	1194
Main unit weight [kg]	Table	S type	7.4	8.5	9.6	10.8	11.9	14.1	15.8	17.5
		L type (SSR15XW)	7.7	8.8	9.9	11.1	12.2	14.4	16.1	17.8
		L type (SHS15V)	8.1	9.2	10.4	11.5	12.7	15.0	16.7	18.4

Note 1: The main unit weight includes the cover weight.

Note 2: The table L(QZ) type shows a QZ specification only for the Ball Screw.

Note 3: The main unit weight of the QZ type is the main unit weight of the table +0.1kg.

[Direct Mounting Specification]

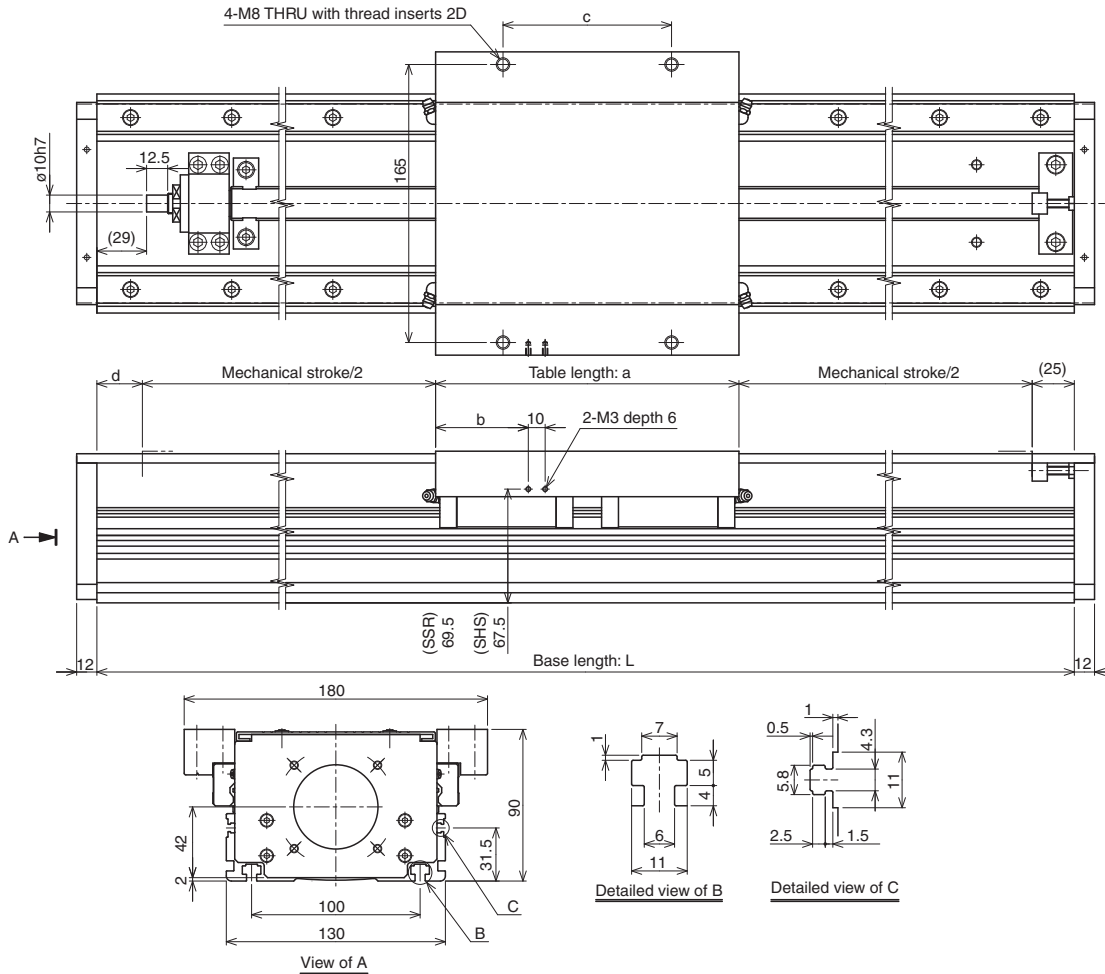

Unit: mm

Table type	Table length: a	b	c	d
S type	160	45	100	37
L type	180	55	100	27
L(QZ) type	180	55	100	34
L-QZ type	210	70	150	5

Base length: L [mm]		460	580	700	820	1060	1240	1420	1600	1780
Mechanical stroke [mm]	Table	S type	238	358	478	598	838	1018	1198	1558
		L type	228	348	468	588	828	1008	1188	1548
		L(QZ) type	221	341	461	581	821	1001	1181	1541
		L-QZ type	220	340	460	580	820	1000	1180	1540
Main unit weight [kg]	Table	S type	9.9	11.5	13.2	14.8	18.1	20.6	23.1	28.0
		L type (SSR20XW)	10.4	12.0	13.7	15.3	18.6	21.1	23.6	28.5
		L type (SHS20V)	11.2	12.9	14.6	16.3	19.7	22.2	24.7	29.8

Note 1: The main unit weight includes the cover weight.

Note 2: The table L(QZ) type shows a QZ specification only for the Ball Screw.

Note 3: The main unit weight of the QZ type is the main unit weight of the table +0.1kg.

Note 4: The maximum base length for the 10mm ball screw lead is 1420mm.

[Lateral Wrap-around Specification]

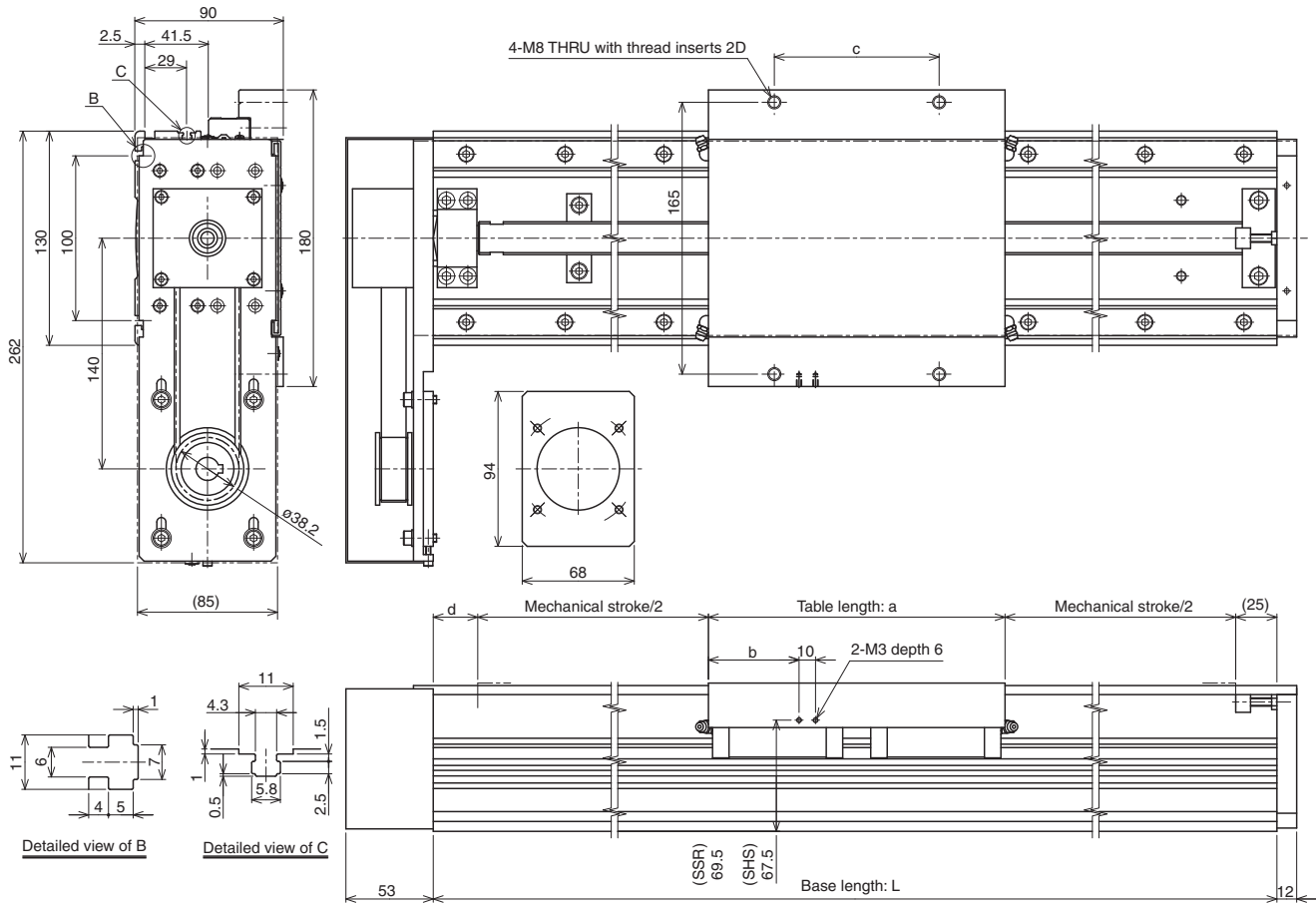

Unit: mm

Table type	Table length: a	b	c	d
S type	160	45	100	37
L type	180	55	100	27
L(QZ) type	180	55	100	34
L-QZ type	210	70	150	5

Base length: L [mm]		460	580	700	820	1060	1240	1420	1600	1780	
Mechanical stroke [mm]	Table	S type	238	358	478	598	838	1018	1198	1378	1558
		L type	228	348	468	588	828	1008	1188	1368	1548
		L(QZ) type	221	341	461	581	821	1001	1181	1361	1541
		L-QZ type	220	340	460	580	820	1000	1180	1360	1540
Main unit weight [kg]	Table	S type	11.8	13.4	15.1	16.7	20.0	22.5	25.0	27.4	29.9
		L type (SSR20XW)	12.3	13.9	15.6	17.2	20.5	23.0	25.5	27.9	30.4
		L type (SHS20V)	13.1	14.8	16.5	18.2	21.6	24.1	26.6	29.2	31.7

Note 1: The main unit weight includes the cover weight.

Note 2: The table L(QZ) type shows a QZ specification only for the Ball Screw.

Note 3: The main unit weight of the QZ type is the main unit weight of the table +0.1kg.

Note 4: The maximum base length for the 10mm ball screw lead is 1420mm.

[Bottom Wrap-around Specification]

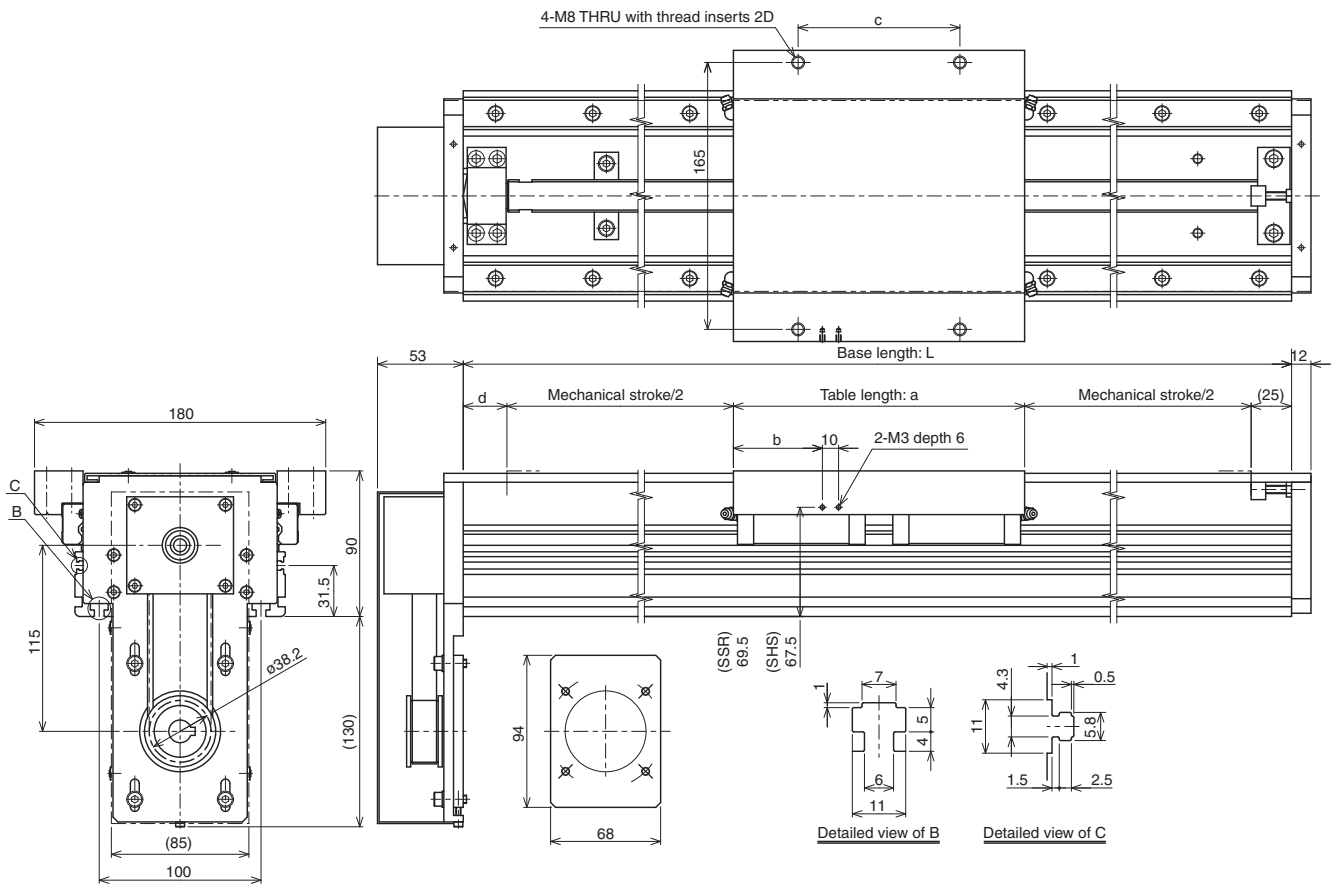

Unit: mm

Table type	Table length: a	b	c	d
S type	160	45	100	37
L type	180	55	100	27
L(QZ) type	180	55	100	34
L-QZ type	210	70	150	5

Base length: L [mm]		460	580	700	820	1060	1240	1420	1600	1780
Mechanical stroke [mm]	S type	238	358	478	598	838	1018	1198	1378	1558
	L type	228	348	468	588	828	1008	1188	1368	1548
	L(QZ) type	221	341	461	581	821	1001	1181	1361	1541
	L-QZ type	220	340	460	580	820	1000	1180	1360	1540
Main unit weight [kg]	S type	11.8	13.4	15.1	16.7	20.0	22.5	25.0	27.4	29.9
	L type (SSR20XW)	12.3	13.9	15.6	17.2	20.5	23.0	25.5	27.9	30.4
	L type (SHS20V)	13.1	14.8	16.5	18.2	21.6	24.1	26.6	29.2	31.7

Note 1: The main unit weight includes the cover weight.

Note 2: The table L(QZ) type shows a QZ specification only for the Ball Screw.

Note 3: The main unit weight of the QZ type is the main unit weight of the table +0.1kg.

Note 4: The maximum base length for the 10mm ball screw lead is 1420mm.

Belt Driven Dimensions

GL15N Model, Belt Driven

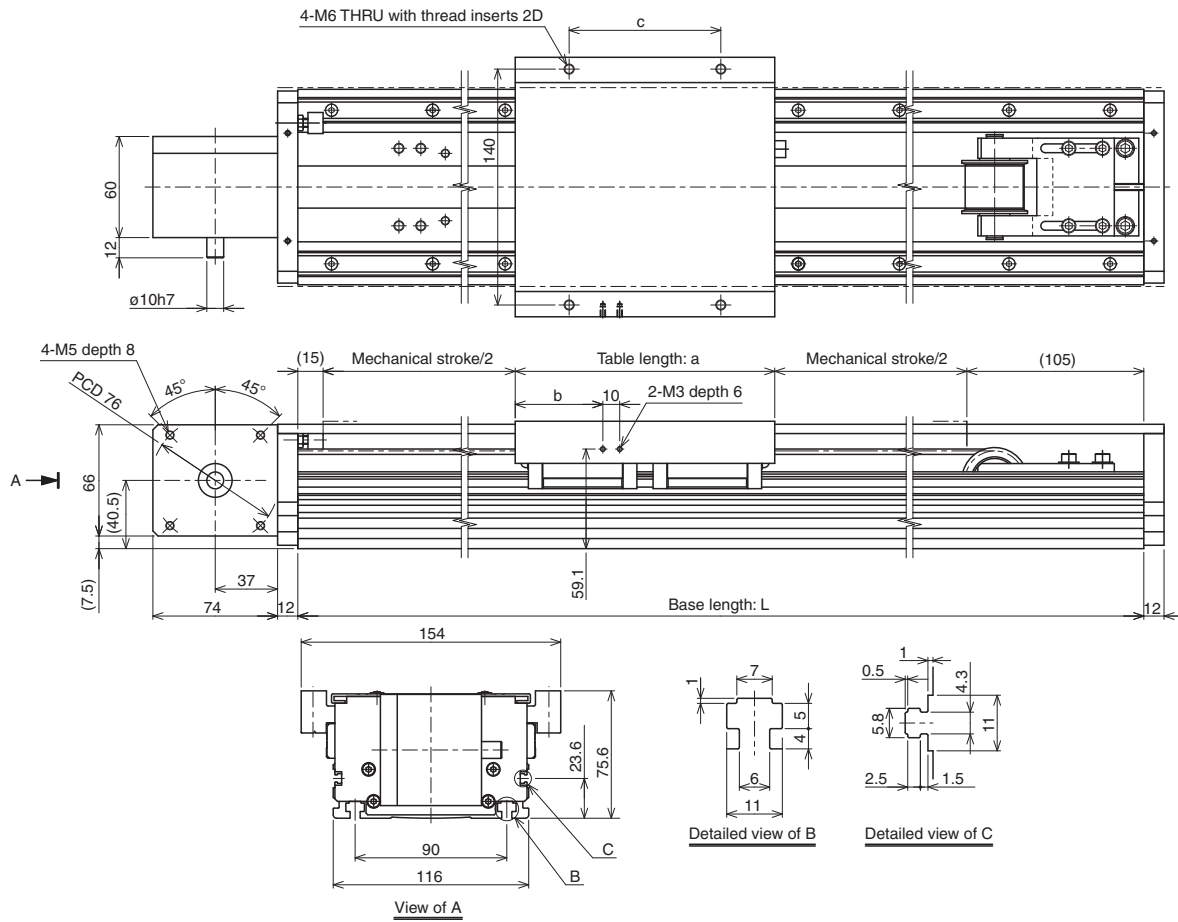

Unit: mm

Table type	Table length: a	b	c
S type	126	38	90
L type	154	52	90
L-QZ type	180	65	120

Base length: L [mm]		340	460	580	700	820	1060	1240	1420	1600	1780	1960	
Mechanical stroke [mm]	Table	S type	94	214	334	454	574	814	994	1174	1354	1534	1714
		L type	66	186	306	426	546	786	966	1146	1326	1506	1686
		L-QZ type	40	160	280	400	520	760	940	1120	1300	1480	1660
Main unit weight [kg]	Table	S type	7.1	8.1	9.1	10.1	11.1	13.1	14.5	16.0	17.5	19.0	20.5
		L type (SSR15XW)	7.4	8.4	9.4	10.4	11.4	13.4	14.8	16.3	17.8	19.3	20.8
		L type (SHS15V)	7.8	8.8	9.8	10.9	11.9	13.9	15.4	16.9	18.5	20.0	21.5

Note 1: The main unit weight includes the cover weight.

Note 2: The main unit weight of QZ type is the main unit weight of the table +0.1kg.

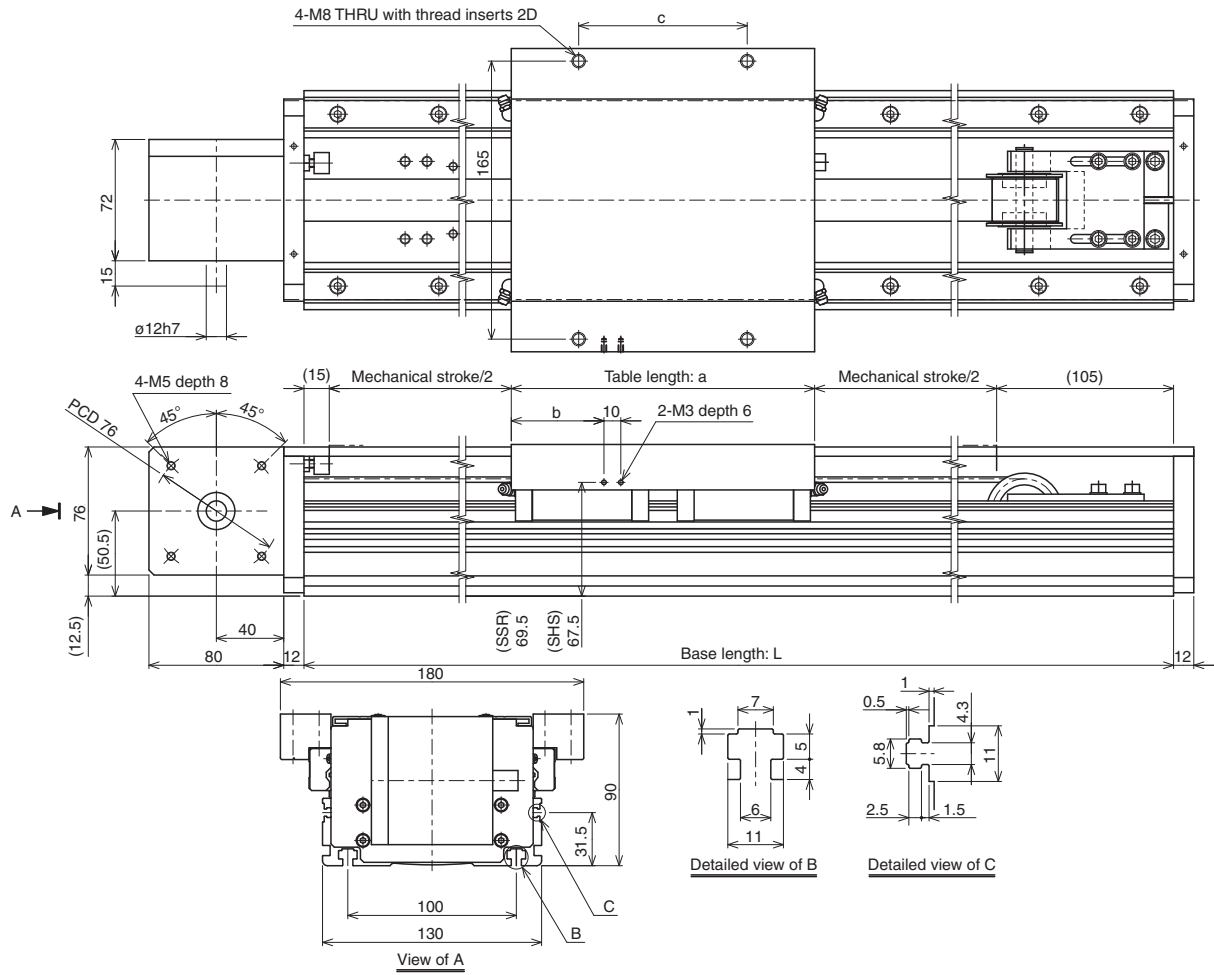

Unit: mm

Table type	Table length: a	b	c
S type	160	45	100
L type	180	55	100
L-QZ type	210	70	150

Base length: L [mm]		460	580	700	820	1060	1240	1420	1600	1780	1960	2200	2320	2500	3000
Mechanical stroke [mm]	Table														
	S type	180	300	420	540	780	960	1140	1320	1500	1680	1920	2040	2220	2720
	L type	160	280	400	520	760	940	1120	1300	1480	1660	1900	2020	2200	2700
Main unit weight [kg]	Table														
	L-QZ type	130	250	370	490	730	910	1090	1270	1450	1630	1870	1990	2170	2670
	S type	11.5	12.9	14.3	15.7	18.6	20.7	22.8	24.9	27.0	29.1	31.9	33.3	35.5	41.3
	L type (SSR20XW)	12.0	13.4	14.8	16.2	19.1	21.2	23.3	25.4	27.5	29.6	32.4	33.8	36.0	41.8
	L type (SHS20V)	12.8	14.2	15.7	17.1	20.1	22.2	24.4	26.6	28.8	31.0	33.9	35.4	37.5	43.6

Note 1: The main unit weight includes the cover weight.

Note 2: The main unit weight of QZ type is the main unit weight of the table +0.1kg.

[LM Guide]

QZ Lubricator, composed of high-density fiber net feeds the right amount of lubricant to the raceway of the LM rail. This allows oil film to continuously be formed between balls and raceways and significantly extends the lubrication and maintenance intervals.

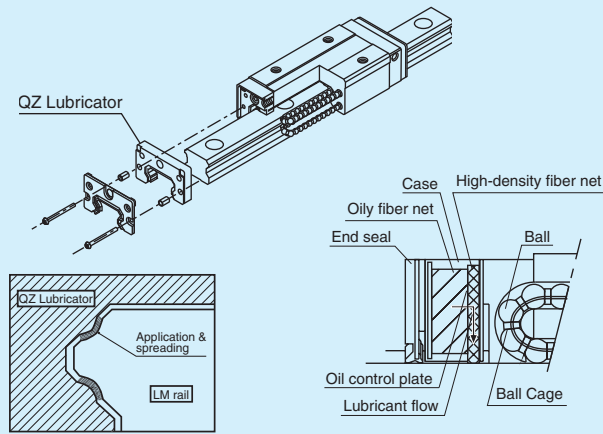

Figure 8 QZ Lubricator Structure Diagram (LM Guide)

[Ball Screw]

An adequate amount of lubricant can be supplied to necessary locations as in the LM Guide portion so that maintenance interval can be greatly extended.

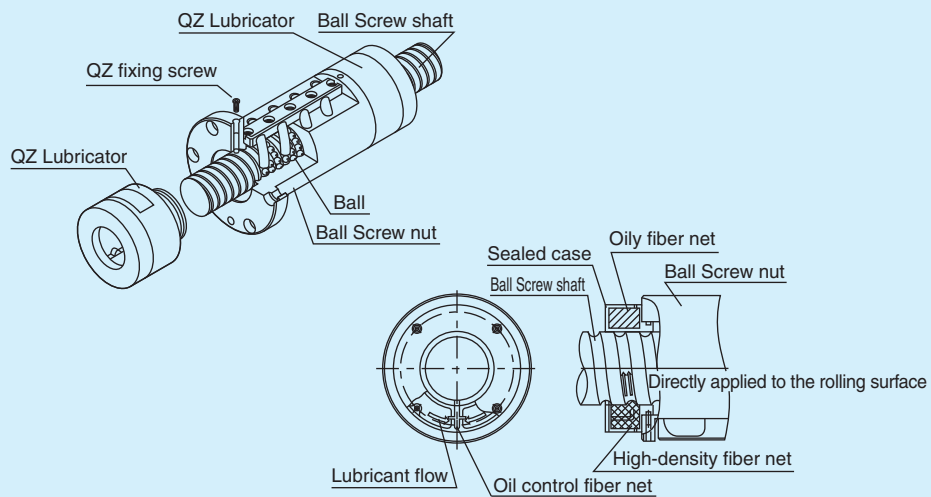

Figure 9 QZ Lubricator Structure Diagram (Ball Screw)

[Control Number]

Motor brackets are available to mount various types of motors. The following table lists by model number the motor brackets available for motors. When purchasing a motor bracket, specify the corresponding model number.

Table 4 Motors and Applicable motor Brackets

	Motor					GL15N		GL20N		
	Manufacturer	Series	Model number	Rated output	Flange angle	Direct motor mounting	Wrap-around	Direct motor mounting	Wrap-around	
AC Servo motor	YASKAWA Electric Corporation	Σ-V	SGMJV-01	100W	□40	A	-	A	-	
			SGMAV-01			A	-	A	-	
			SGMJV-02	200W	□60	B	B14	B	B14	
			SGMAV-02			B	B14	B	B14	
			SGMJV-04	400W	□60	-	-	B	B14	
			SGMAV-04			-	-	B	B14	
		Σ-III	SGMAS-01	100W	□40	A	-	A	-	
			SGMPS-01			B	-	B	-	
			SGMAS-02	200W	□60	B	B14	B	B14	
			SGMAS-04	400W		-	-	B	B14	
			SGMPS-02	200W	□80	-	-	J	J14	
			SGMPS-04	400W		-	-	J	J14	
		Σ-II	SGMAH-01	100W	□40	A	-	A	-	
			SGMPH-01			B	-	B	-	
			SGMAH-02	200W	□60	B	B14	B	B14	
			SGMAH-04	400W		-	-	B	B14	
	SGMPH-02		200W	□80	-	-	J	J14		
	SGMPH-04		400W		-	-	J	J14		
	Mitsubishi Electric Corporation	MELSERVO	J3	HF-MP13	100W	□40	A	-	A	-
				HF-KP13			A	-	A	-
				HF-MP23	200W	□60	B	B14	B	B14
			HF-KP23	B			B14	B	B14	
			HF-MP43	400W	□60	-	-	B	B14	
			HF-KP43			-	-	B	B14	
		J2-Super	HC-MFS13	100W	□40	A	-	A	-	
			HC-KFS13			A	-	A	-	
			HC-MFS23	200W	□60	B	B14	B	B14	
			HC-KFS23			B	B14	B	B14	
	HC-MFS43	400W	□60	-	-	B	B14			
	HC-KFS43			-	-	B	B14			
	Panasonic Corporation	MINAS A4		MSMD01	100W	□38	E	-	E	-
				MQMA01			F	-	F	-
				MSMD02	200W	□60	F	F11	F	F11
				MSMD04			400W	-	-	F
			MQMA02	200W	□80	-	-	D	D11	
			MQMA04			400W	-	-	D	D14
			MINAS A III	MSMA01	100W	□38	E	-	E	-
				MSMA02			200W	F	F11	F
		MSMA04		400W	□60	-	-	F	F14	
		MSMA01				100W	□38	E	-	E
MQMA01		200W	□60	F	-			F	-	
MSMA02				400W	□80	F	F11	F	F11	
MSMA04		400W	□80			-	-	F	F14	
MQMA02				200W	□80	-	-	D	D11	
MQMA04		400W	□80			-	-	D	D14	
OMRON Corporation				OMNUC W	R88M-U10030	100W	□40	A	-	A
		R88M-W10030	A		-			A	-	
		R88M-WP10030	200W		□60	B	-	B	-	
	R88M-U20030	B				B14	B	B14		
	R88M-W20030	400W	□60		B	B14	B	B14		
	R88M-U40030				-	-	B	B14		
	R88M-W40030	200W	□80		-	-	B	B14		
	R88M-WP20030				-	-	J	-		
	R88M-WP40030	400W	□80		-	-	J	-		
	R88M-WP40030				-	-	J	-		
FANUC	β is series	β 0.3/5000is	100W	□40	A	-	A	-		
		β 0.4/5000is			125W	B	-	B	-	
		β 0.5/5000is	200W	□60	B	B9	B	B9		
		β 1/5000is			400W	-	-	B	B14	
Sanyo Denki Co.,Ltd.	SANMOTION Q1	Q1AA04010D	100W	□40	A	-	A	-		
		Q1AA06020D	200W	□60	B	B14	B	B14		
		Q1AA06040D	400W		-	-	B	B14		
Stepping motor	ORIENTAL MOTOR Co.,Ltd.	5-phase	RK	-	□60	H	-	H	-	
						RK564	H	-	H	-
						RK566	H	-	H	-
		RK569	□85		-	-	I	-		
		RK596			-	-	I	-		
		RK599			-	-	I	-		
	α step	AS66	□60	H	-	H	-			
		ASC66		H	-	H	-			
		AS98		□85	-	-	I	-		
		AS98			-	-	I	-		

Note: A motor shaft for motor wrap option will need a key.

[Dimensional Drawing]

• Direct motor mounting

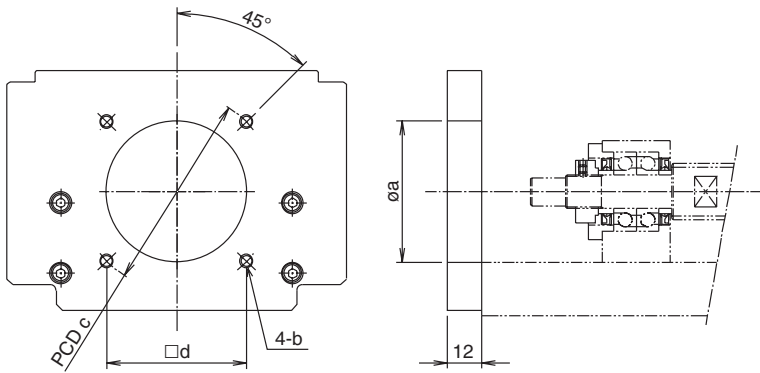

Table 5 Motor Mounting Plate Unit: mm

Bracket Symbol	Motor mount dimensions			
	a	b	c	d
A	30H7	M4	46	-
B	50H7	M5	70	-
C	50H7	M4	60	-
D	70H7	M5	90	-
E	30H7	M3	45	-
F	50H7	M4	70	-
G	34H7	M3	48	-
H	36H7	M4	-	50
I	60H7	M6	-	70
J	70H7	M6	90	-

• Motor wrap-around

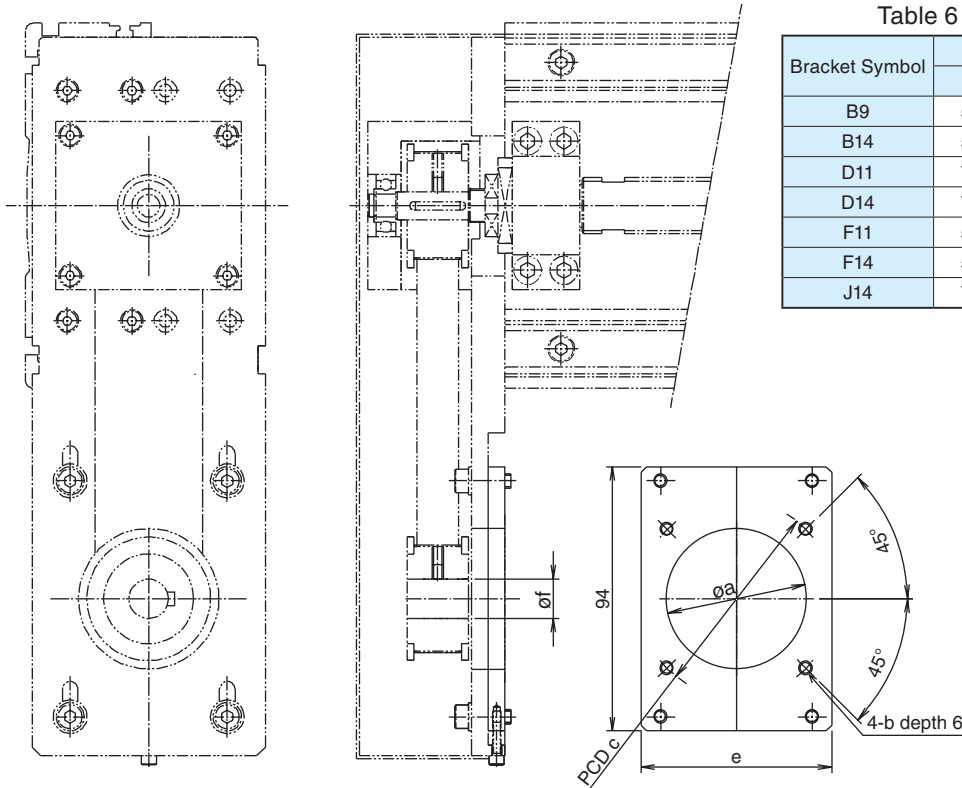

Table 6 Motor Mounting Plate Unit: mm

Bracket Symbol	Motor mount dimensions				
	a	b	c	e	f
B9	50	M5	70	68	9
B14	50	M5	70	68	14
D11	70	M5	90	80	11
D14	70	M5	90	80	14
F11	50	M4	70	68	11
F14	50	M4	70	68	14
J14	70	M6	90	80	14

Motor Bracket (Belt Type Specification)

[Control Number]

Motor brackets are available that allow different motors to be attached. The following table lists control numbers for motors with reducers and motor brackets applicable for reducers by their model numbers. Please specify the corresponding model number.

Table 7 Motors and Applicable Motor Brackets

Motor (Reducer)						Common to both, GL15N and GL20N	
Manufacturer	Series	Model Number	Rated output	Reduction Ratio			
Servomotor with reducer	YASKAWA Electric Corporation	Σ-III	SGMAS-01A*AJ1	100W	1/5	A1	
			SGMAS-02A*AJ1	200W	1/5	A2	
		Σ-II	SGMAH-01**AJ1	100W	1/5	A1	
			SGMAH-02**AJ1	200W	1/5	A2	
	Mitsubishi Electric Corporation	MELSERVO	J3	HF-KP13G1	100W	1/5	C1
				HF-MP13G1		1/12	C1
				J2-Super	HC-MFS13G1	100W	1/5
			HC-KFS13G1		100W	1/12	C1
			HC-KFS13G1			1/5	C1
			Panasonic Corporation	MINAS A4	MSMD01***1N	100W	1/5
	MSMD02***1N	200W			1/5	B1	
	MSMD04***1N	400W			1/5	B2	
	MINAS A	MSMA01**32		100W	1/5	B1	
		MSMA02**32		200W	1/5	B1	
MSMA04**32		400W		1/5	B2		
Reducer	SHIMPO DRIVES, INC.	VR	VR*F-3B-100	100W	1/3	B1	
			VR*F-5B-100		1/5	B1	
			VR*F-3B-200	200W	1/3	B1	
			VR*F-5B-200		1/5	B1	
			VR*F-3B-400	400W	1/3	B1	
			VR*F-5C-400		1/5	B2	

[Dimensional Drawing]

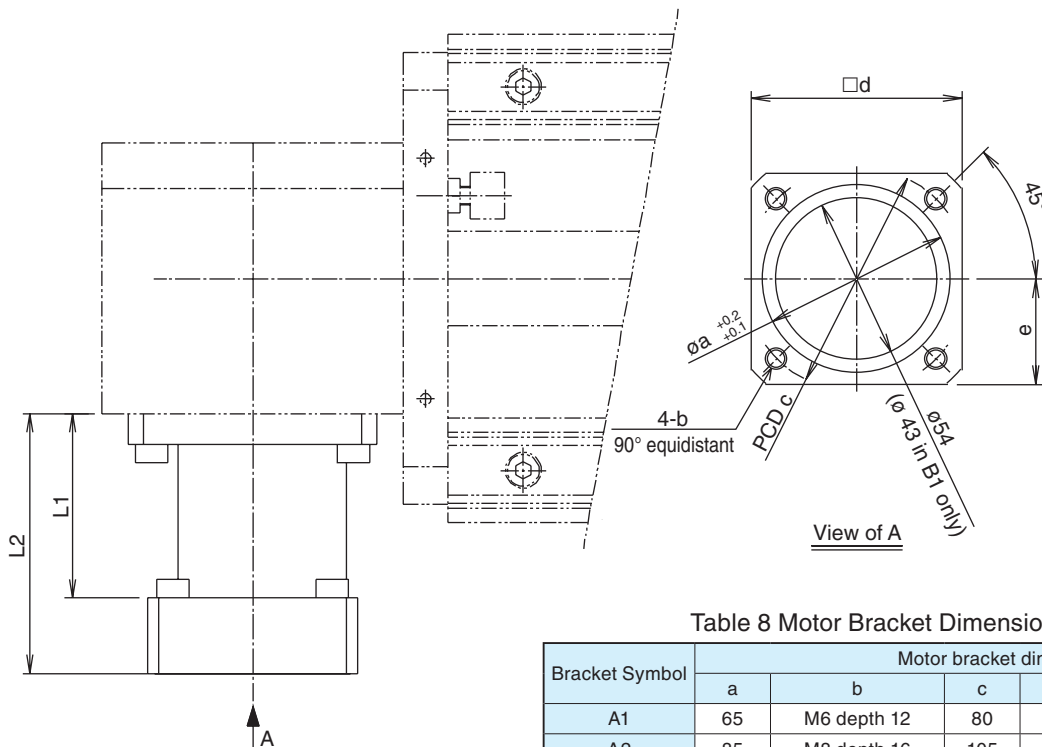

Table 8 Motor Bracket Dimensional Drawing

Unit: mm

Bracket Symbol	Motor bracket dimensions						
	a	b	c	d	e	L1	L2
A1	65	M6 depth 12	80	70	35	59	98
A2	85	M8 depth 16	105	90	45	66	112
B1	50	5.5 THRU	60	56	28	49	69
B2	70	6.6 THRU	90	78	39	60	86
C1	60	M6 depth 12	75	66	33	54	98

[Control Number]

The following table lists reducers and motors available with motor bracket B1 or B2. It also shows the control numbers of reducers available with the motors. When purchasing a reducer, specify the corresponding control number.

Table 9 Motors and Applicable Reducer

	Motor				Reduction ratio					
	Manufacture	Series	Model number	Rated output	1/3	1/5	1/9			
AC Servo motor	YASKAWA Electric Corporation	Σ-V	SGMAV-01	100W	B1G103	B1G105	B1G109			
			SGMAV-02	200W	B1G303	B1G305	B2G309			
			SGMAV-04	400W	B1G303	B2G305	B2G309			
			SGMAS-01	100W	B1G103	B1G105	B1G109			
			SGMAS-02	200W	B1G303	B1G305	B2G309			
			SGMAS-04	400W	B1G303	B2G305	B2G309			
		Σ-III	SGMAH-01	100W	B1G103	B1G105	B1G109			
			SGMAH-02	200W	B1G303	B1G305	B2G309			
			SGMAH-04	400W	B1G303	B2G305	B2G309			
			Σ-II	HF-MP13	100W	B1G103	B1G105	B1G109		
				HF-KP13		B1G103	B1G105	B1G109		
				HF-MP23		B1G303	B1G305	B2G309		
	Mitsubishi Electric Corporation	MELSERVO		J3	HF-KP23	200W	B1G303	B1G305	B2G309	
					HF-MP43		B1G303	B2G305	B2G309	
					HF-KP43		B1G303	B2G305	B2G309	
			J2-Super	HC-MFS13	100W	B1G103	B1G105	B1G109		
				HC-KFS13		B1G103	B1G105	B1G109		
				HC-MFS23		B1G303	B1G305	B2G309		
	Panasonic Corporation	MINAS A4		MINAS A	HC-KFS23	200W	B1G303	B1G305	B2G309	
					HC-MFS43		B1G303	B2G305	B2G309	
					HC-KFS43		B1G303	B2G305	B2G309	
			MINAS A	MSMD01	100W	B1G203	B1G205	B1G209		
				MSMD02		B1G403	B1G405	B2G409		
				MSMD04		B1G503	B2G505	B2G509		
	OMRON Corporation	OMNUC W		MINAS A	MSMA01	100W	B1G203	B1G205	B1G209	
					MSMA02		B1G403	B1G405	B2G409	
					MUMA02		B1G403	B1G405	B2G409	
			OMRON Corporation	OMNUC W	MINAS A	MUMA04	400W	B1G503	B2G505	B2G509
						MUMA04		B1G503	B2G505	B2G509
						MUMA04		B1G503	B2G505	B2G509
Sanyo Denki Co.,Ltd.	SANMOTION Q1	OMNUC W	R88M-U10030		100W	B1G103	B1G105	B1G109		
			R88M-W10030			B1G103	B1G105	B1G109		
			R88M-U20030		200W	B1G303	B1G305	B2G309		
			R88M-W20030	B1G303		B1G305	B2G309			
			R88M-U40030	400W	B1G303	B2G305	B2G309			
			R88M-W40030		B1G303	B2G305	B2G309			
Sanyo Denki Co.,Ltd.	SANMOTION Q1	OMNUC W	Q1AA04010D	100W	B1G103	B1G105	B1G109			
			Q1AA06020D		B1G303	B1G305	B2G309			
			Q1AA06040D		B1G303	B2G305	B2G309			

Note 1: B1: VR*F-B (SHIMPO DRIVES, INC.); B2: VR*F-C (SHIMPO DRIVES, INC.)

Note 2: When ordering a belt drive with reducer inform us of the model number of the motor to which it is to be attached.

[Dimensional Drawing]

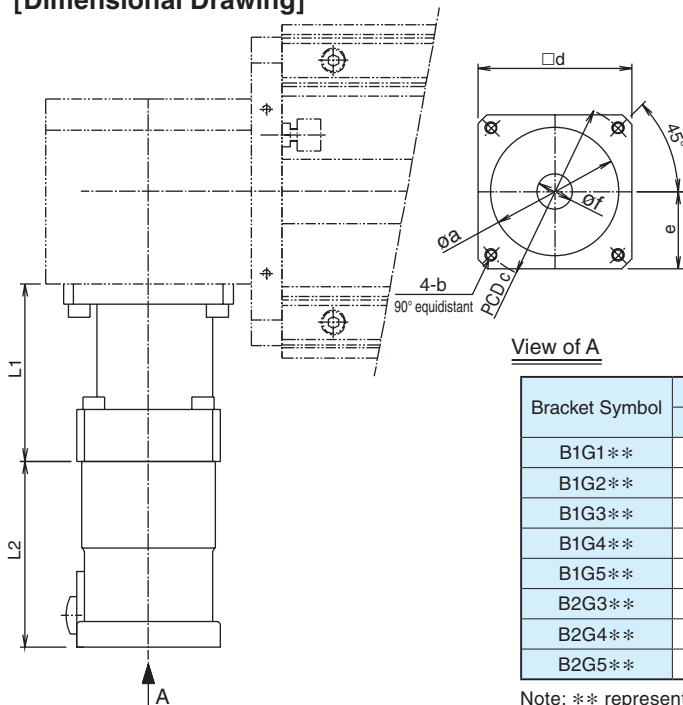

View of A

Table 10 Reducer Dimensional Drawing

Unit: mm

Bracket Symbol	Motor bracket dimensions							L1	L2
	a	b	c	d	e	f			
B1G1**	30	M4 depth 10	46	40	20	8	69	67.5	
B1G2**	30	M3 depth 8	45	38	19	8	69	67.5	
B1G3**	50	M5 depth 10	70	60	30	14	69	72.5	
B1G4**	50	M4 depth 10	70	60	30	11	69	72.5	
B1G5**	50	M4 depth 10	70	60	30	14	69	72.5	
B2G3**	50	M5 depth 10	70	60	30	14	86	89.5	
B2G4**	50	M4 depth 10	70	60	30	11	86	89.5	
B2G5**	50	M4 depth 10	70	60	30	14	86	89.5	

Note: ** represents an actual gear ratio

The GL-N model has an anti-dust cover.
This cover is common to GL15N and GL20N.

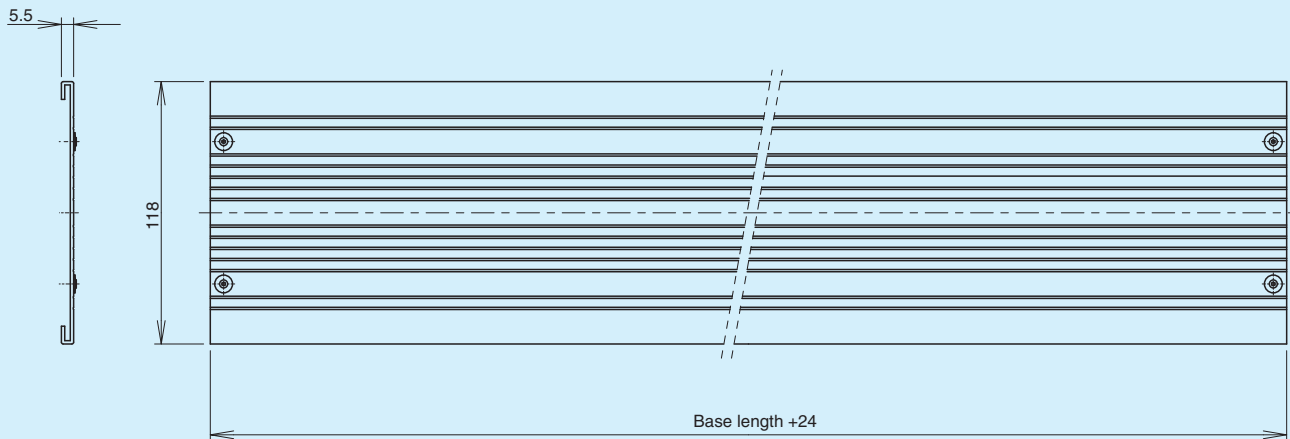

Figure 10 Cover Outline View

Note 1: Deflection of the cover increases as the base length increases. A cover-support is attached to the table to prevent table interference (See the diagram below). This is attached as standard from models with base lengths above 1000 mm. The cover may touch another part such as the rail and belt, because deflection caused by the cover's own weight increases.

Note 2: If the GL-N model is used in any position other than horizontal, a part mounted on the table might touch the cover due to deflection caused by the cover.

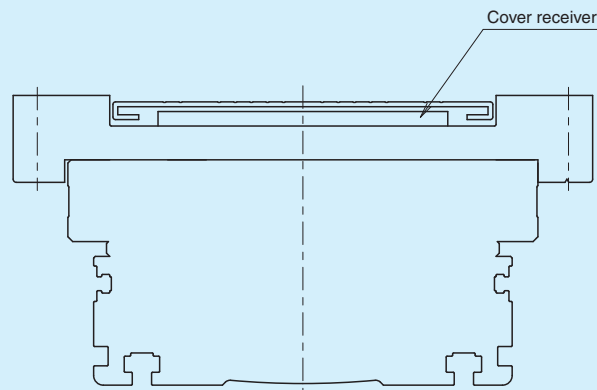
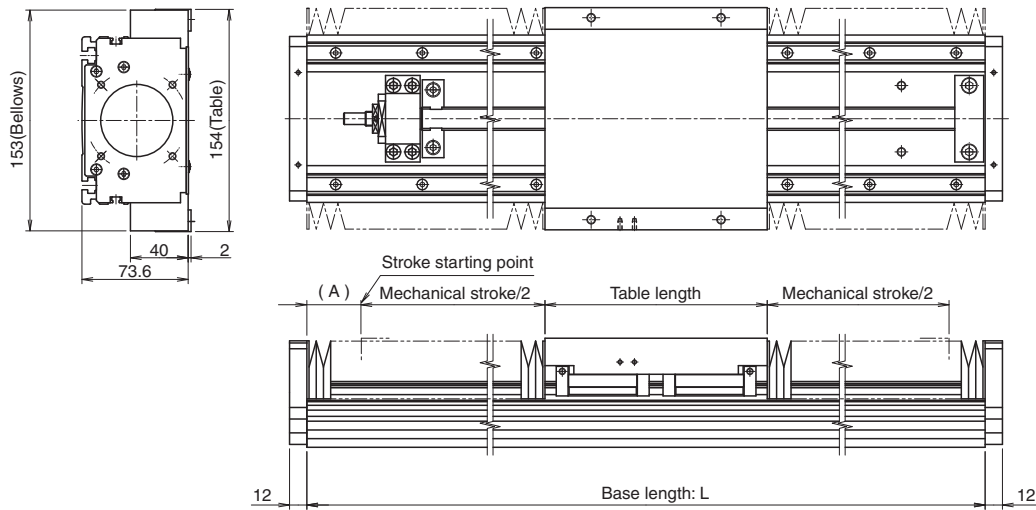

Figure 11 Section View of a Model with a Cover Receiver

The GL-N model has an anti-dust bellows as well as an anti-dust cover.

[GL15N Model, Ball Screw Driven]



Unit: mm

Base length: L		340	460	580	700	820	1060	1240	1420	
Mechanical stroke	Table	S type	133	248	358	468	563	763	913	1058
		L type	119	234	340	440	535	735	885	1030
		L(QZ) type	110	225	335	440	535	735	885	1030
		L-QZ type	104	214	314	414	509	709	859	1004
Stroke starting point: A	Table	S type	53	53	53	53	65.5	85.5	100.5	118
		L type	39	39	43	53	65.5	85.5	100.5	118
		L(QZ) type	48	48	48	53	65.5	85.5	100.5	118
		L-QZ type	28	33	43	53	65.5	85.5	100.5	118

[GL20N Model, Ball Screw Driven]

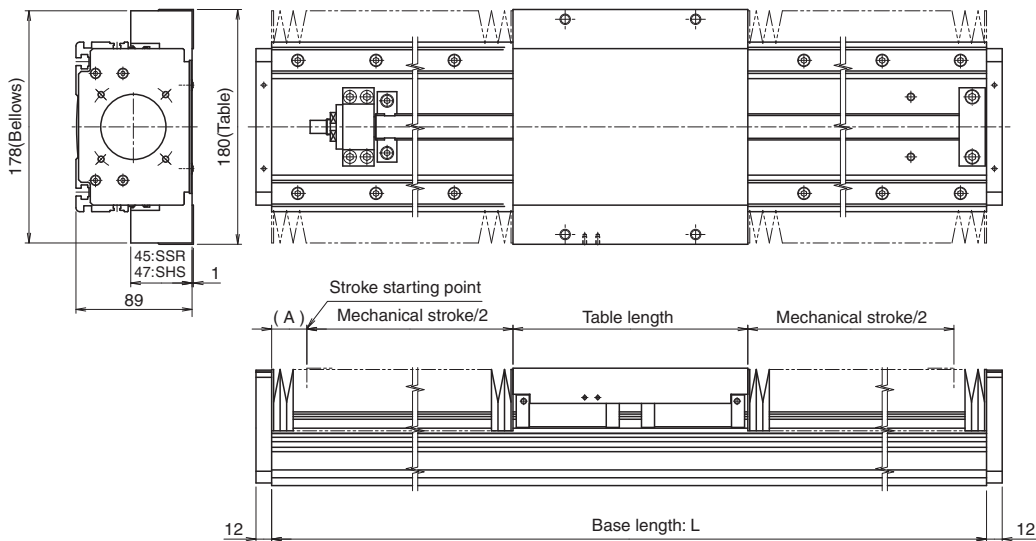

Unit: mm

Base length: L		460	580	700	820	1060	1240	1420	1600	1780	
Mechanical stroke	Table	S type	237	352	464	569	779	939	1094	1254	1409
		L type	227	339	444	549	759	919	1074	1234	1389
		L(QZ) type	220	336	444	549	759	919	1074	1234	1389
		L-QZ type	198	309	414	519	729	889	1044	1204	1359
Stroke starting point: A	Table	S type	37	37	38	45.5	60.5	70.5	83	93	105.5
		L type	27	30.5	38	45.5	60.5	70.5	83	93	105.5
		L(QZ) type	34	34	38	45.5	60.5	70.5	83	93	105.5
		L-QZ type	25.5	30.5	38	45.5	60.5	70.5	83	93	105.5

[GL15N Model, Belt Driven]

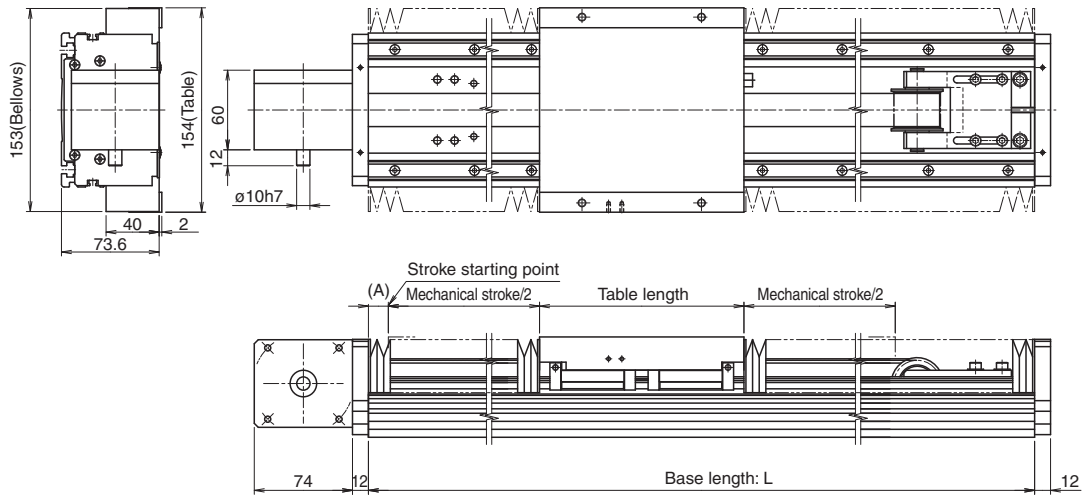

Unit: mm

Base length: L		340	460	580	700	820	1060	1240	1420	1600	1780	1960	
Mechanical stroke	Table	S type	78	186	291	396	501	698	833	973	1108	1243	1378
		L type	50	158	263	368	473	670	805	945	1080	1215	1350
		L-QZ type	24	132	237	342	447	644	779	919	1054	1189	1324
Stroke starting point: A		31	43	58	73	88	118	140.5	160.5	183	205.5	228	

[GL20N Model, Belt Driven]

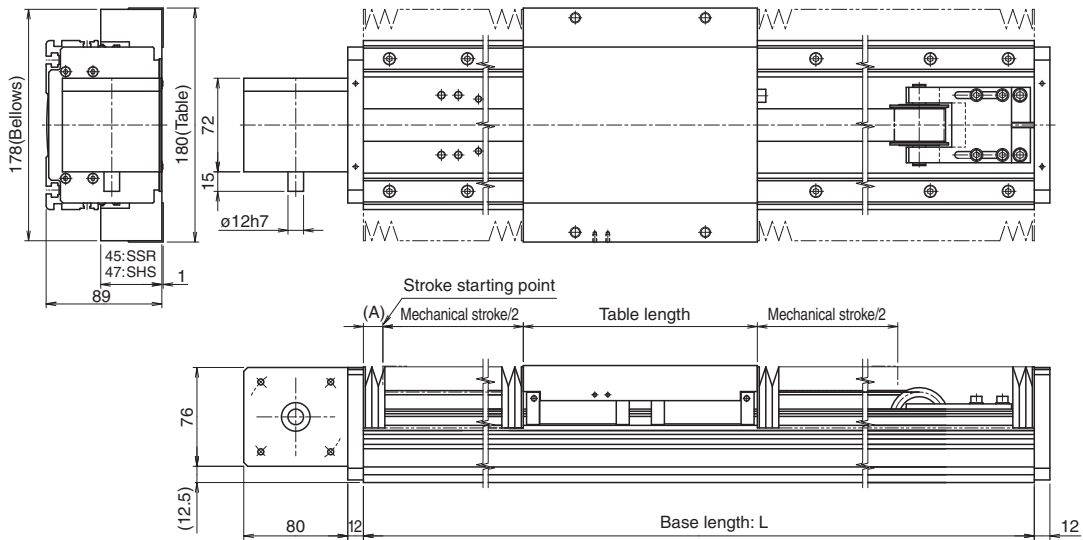

Unit: mm

Base length: L		460	580	700	820	1060	1240	1420	1600	1780	1960	2200	2320	2500	3000	
Mechanical stroke	Table	S type	159	267	374	482	697	849	989	1134	1274	1419	1609	1704	1844	2239
		L type	139	247	354	462	677	829	969	1114	1254	1399	1589	1684	1824	2219
		L-QZ type	109	217	324	432	647	799	939	1084	1224	1369	1559	1654	1794	2189
Stroke starting point: A		36	48	61	73	98	115.5	135.5	153	173	190.5	215.5	228	248	300.5	

The GL-N model allows various sensors to be set to the T groove at the side of the base.

[Control Number]

Type	Logic Mode	Sensor Model Number Type	Quantity	Manufacturer	Accessories	Symbol
Photo sensor	Selectable	EE-SX671	3	OMRON	Mounting bolts and nuts, Sensor target, Mounting plate	A
	Selectable	EE-SX674	3	OMRON	Mounting bolts and nuts, Sensor target, Mounting plate	B
Proximity sensor	N.O. (Normally Open)	TL-W3MC1	3	OMRON	Mounting bolts and nuts, Sensor target	C1
	N.O. (Normally Open)	TL-W3MC1	1			
	N.C. (Normally Closed)	TL-W3MC2	2			C2

Note 1: All sensor outputs are NPN outputs.

Note 2: The sensor and accessories are provided with the product.

Note 3: N.O.contact: Normally Open type

N.C.contact: Normally Closed type

[Dimensional Drawing]

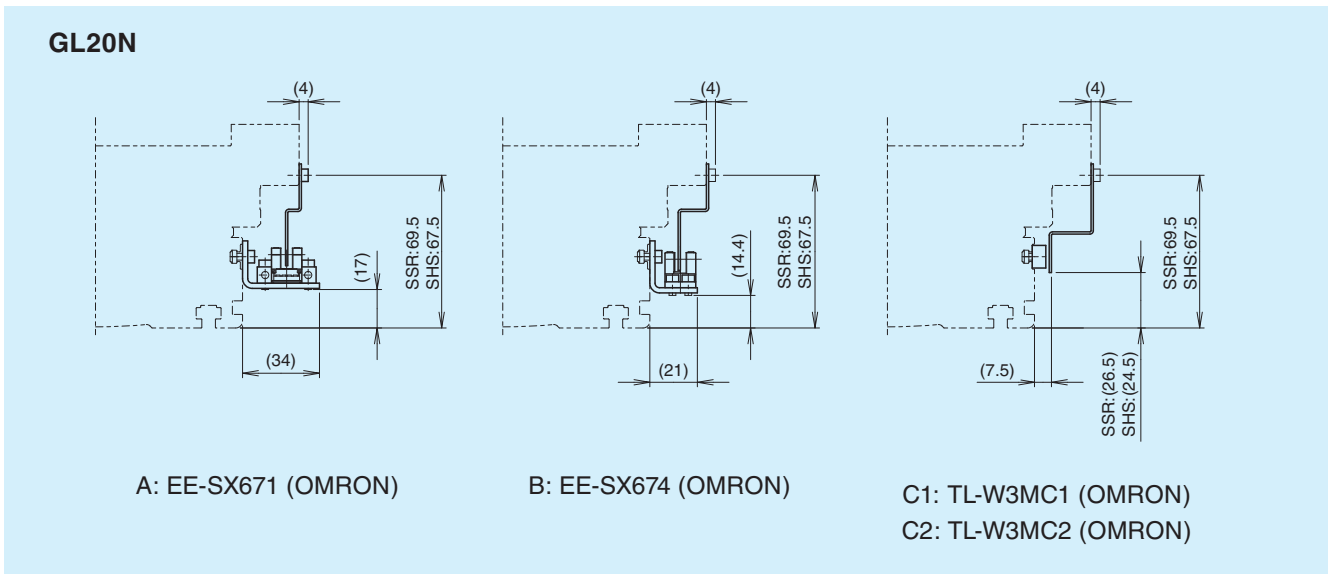
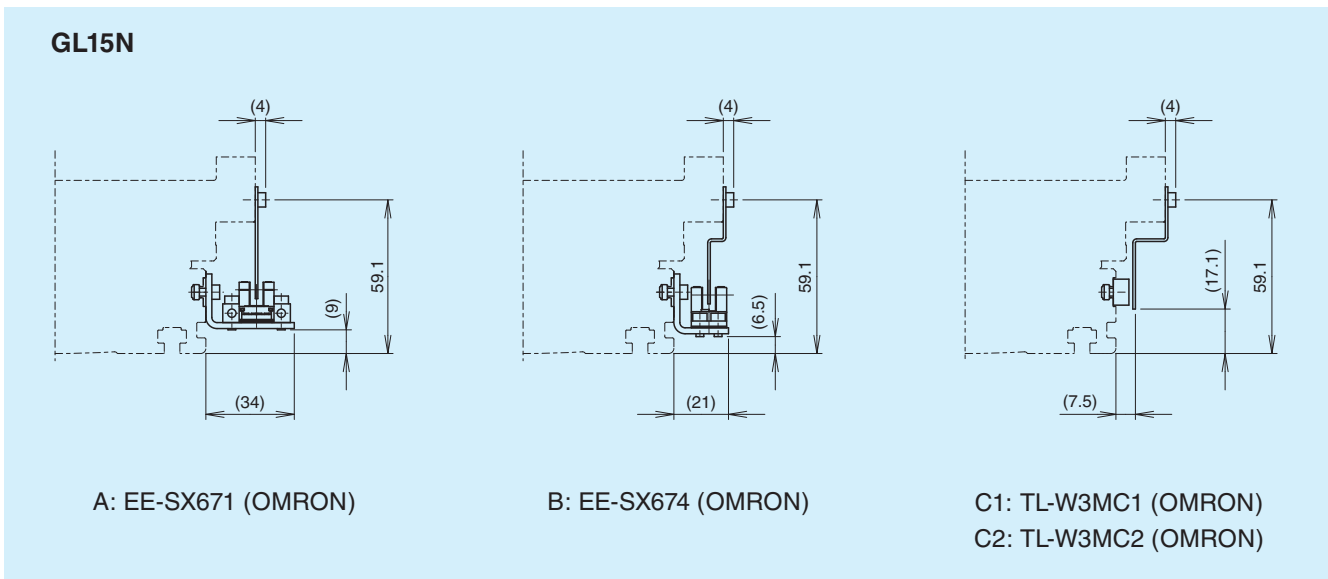

Cable Carrier

The GL-N model enables various cable carriers to be set to the T groove at the side of the base.

[Control Number]

Cable carrier model number	Manufacturer	Symbol
TKP0180-W40-R28	TSUBAKIMOTO CHAIN CO.	A
TKP0180-W40-R37		B
TKP0180-W40-R50		C
TKP0320-W24-R37		D
TKP0320-W24-R50		E

Cable carrier model number	Manufacturer	Symbol
TKP0320-W24-R75	TSUBAKIMOTO CHAIN CO.	F
TKP0320-W50-R37		G
TKP0320-W50-R50		H
TKP0320-W50-R75		I
KSH-24L-42	THK	J

Note: For the selection of cable carriers, etc., refer to the catalogs of cable carriers.

[Dimensional Drawing]

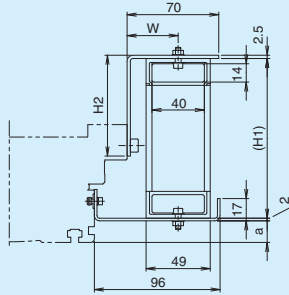

Unit: mm

Symbol	Cable carrier model number	H1	H2	Dimensions			
				W		a	
				GL15N	GL20N	GL15N	GL20N
A	TKP0180-W40-R28	(78)	33	45	39	8.6	16.5
B	TKP0180-W40-R37	(96)	51				
C	TKP0180-W40-R50	(122)	77				

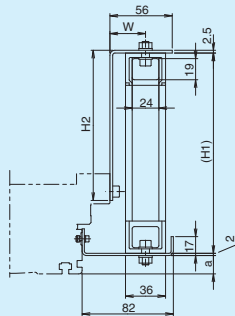

Unit: mm

Symbol	Cable carrier model number	H1	H2	Dimensions			
				W		a	
				GL15N	GL20N	GL15N	GL20N
D	TKP0320-W24-R37	(104)	59	38	32	8.6	16.5
E	TKP0320-W24-R50	(130)	85				
F	TKP0320-W24-R75	(180)	135				

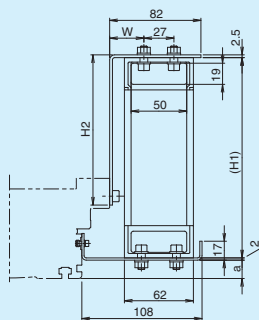

Unit: mm

Symbol	Cable carrier model number	H1	H2	Dimensions			
				W		a	
				GL15N	GL20N	GL15N	GL20N
G	TKP0320-W50-R37	(104)	59	36.75	30.75	8.6	16.5
H	TKP0320-W50-R50	(130)	85				
I	TKP0320-W50-R75	(180)	135				

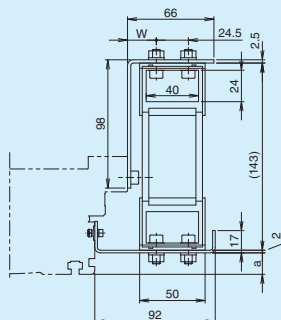

Unit: mm

Symbol	Cable carrier model number	Dimensions			
		W		a	
		GL15N	GL20N	GL15N	GL20N
J	KSH-24L-42	28	22	8.6	16.5

Nut for mounting the base (accessory)

For model GL-N, T-Slot Nuts for mounting the base are available. T-Slot Nuts for mounting the base are included.

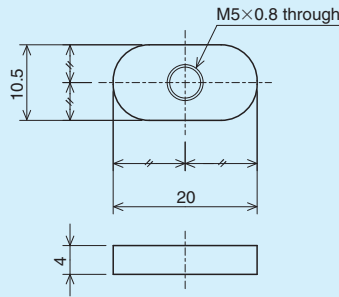

Standard base length (mm)	340	460	580	700	820	1060	1240	1420	1600	1780	1960	2200	2320	2500	3000
Quantity	4	4	6	6	8	10	10	12	14	14	16	16	18	18	20

T-Slot Nuts for base mounting are included.

Appendix

Service Life Time and Static Safety factor

The GL-N model consists of LM Guides, a ball screw, and support units. The life and safety factor of each component can be calculated from the basic dynamic load rating and the basic static load rating. For more information on these, refer to each item (LM Guides, ball screws, and support units) in the general catalog.

The nominal life of the LM Guides and ball screw can be calculated using the technical calculation software available from the THK Technical Support Site (<https://tech.thk.com/>) or contained in the CD-ROM catalog. In calculating the nominal life, see the data in the following table.

Note: Please note that the calculation of life is theoretical. In actual use, the life varies depending on the service conditions such as the usage environment, the lubricating condition, the accuracy or rigidity of the area where the LM actuator is installed, and so forth.

[LM Guide]

Actuator model number	Table type	LM Guide model number	Thrust position		Rail span W (mm)	Block span L1 (mm)	Movable section			Slider height H (mm)	
			B1 (mm)	B2 (mm)			Mass m1 (kg)	Gravity center G1 (mm) G2 (mm) G3 (mm)			
GL15N-***-SV-B	S	SSR15XVUU-Y	45	-5.4	90	82	1.7	45	41	30	43
GL15N-***-SW-B	L	SSR15XWUU-Y		-5.4		74	2.2		37	30	43
GL15N-***-SWQ-B	L-QZ	SSR15XWQZUU-Y		-5.4		94	2.4		47	30	43
GL15N-***-HV-B	L	SHS15VUU		-5.4		74	2.2		37	30	43
GL15N-***-HVQ-B	L-QZ	SHS15VQZUU		-5.4		94	2.4		47	30	43
GL20N-***-SV-B	S	SSR20XVUU	51	-2	102	108	2.7	51	54	34.6	48
GL20N-***-SW-B	L	SSR20XWUU		-2		108	3.2		54	34.6	48
GL20N-***-SWQ-B	L-QZ	SSR20XWQZUU		-2		110	3.4		55	34.6	48
GL20N-***-HV-B	L	SHS20VUU		-4		96	3.6		48	36.6	50
GL20N-***-HVQ-B	L-QZ	SHS20VQZUU		-4		110	3.8		55	36.6	50
GL15N-***-SV-E	S	SSR15XVUU-Y	45	-26	90	82	1.2	45	41	30	43
GL15N-***-SW-E	L	SSR15XWUU-Y		-26		74	1.7		37	30	43
GL15N-***-SWQ-E	L-QZ	SSR15XWQZUU-Y		-26		94	1.8		47	30	43
GL15N-***-HV-E	L	SHS15VUU		-26		74	1.7		37	30	43
GL15N-***-HVQ-E	L-QZ	SHS15VQZUU		-26		94	1.8		47	30	43
GL20N-***-SV-E	S	SSR20XVUU	51	-27	102	108	2.1	51	54	34.6	48
GL20N-***-SW-E	L	SSR20XWUU		-27		108	2.6		54	34.6	48
GL20N-***-SWQ-E	L-QZ	SSR20XWQZUU		-27		110	2.8		55	34.6	48
GL20N-***-HV-E	L	SHS20VUU		-29		96	3.0		48	36.6	50
GL20N-***-HVQ-E	L-QZ	SHS20VQZUU		-29		110	3.2		55	36.6	50

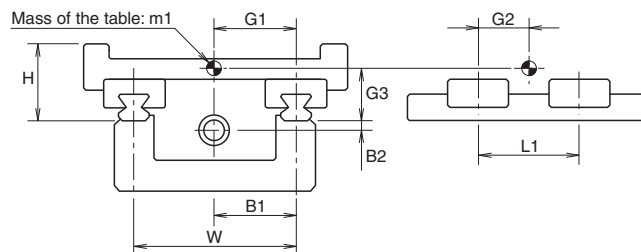

[Ball Screw]

Actuator model number			Mechanical stopper-to-mechanical stopper stroke (mm)			Ball screw			
Nominal model number	Base length* (mm)	Ball screw	S type	L type	L-QZ type	Mounting method	Category	Nut model number	Mounting distance
			SV	SW, HV	SWQ, HVQ				MAX (mm)
GL15N	034	B05	136	122	114	Fixed-support	Rolled-without pre-load	BTK1605-2.6ZZ	186
	142		1216	1202	1194				1266
GL15N	034	B10	136	122	114	Fixed-support	Rolled-without pre-load	BLK1510-5.6ZZ	179
	142		1216	1202	1194				1259
GL15N	034	B16	136	122	114	Fixed-support	Rolled-without pre-load	BLK1616-3.6	176
	142		1216	1202	1194				1256
GL15N	034	B20	136	122	114	Fixed-support	Rolled-without pre-load	WTF1520-3ZZ	179
	142		1216	1202	1194				1259
GL15N	034	B30	136	122	114	Fixed-support	Rolled-without pre-load	WTF1530-2ZZ	179
	142		1216	1202	1194				1259
GL20N	046	B05	238	228	220	Fixed-support	Rolled-without pre-load	BTK2005-2.6ZZ	299
	178		1558	1548	1540				1619
GL20N	046	B10	238	228	220	Fixed-support	Rolled-without pre-load	BLK1510-5.6ZZ	299
	142		1198	1188	1180				1259
GL20N	046	B20	238	228	220	Fixed-support	Rolled-without pre-load	BLK2020-3.6ZZ	297
	178		1558	1548	1540				1617
GL20N	046	B40	238	228	220	Fixed-support	Rolled-without pre-load	WTF2040-2ZZ	297
	178		1558	1548	1540				1617

* The base length shows the minimum and maximum lengths.
Example: 034 for a base length of 340mm and 142 for a base length of 1420mm

[Support Unit]

Nominal model number	Support unit fixed side				Support unit support side	
	Angular ball bearing				Deep-groove ball bearing	
	Model number	Bearing model number			Model number	Bearing model number
GL15N	GK10S	7000HTDFGMP5 (Direct-mounting specification)			GF10	608ZZ
		7000HTDBGMP5 (Wrap-around specification)				
GL20N	GK12S	7001HTDFGMP5 (Direct-mounting specification)			GF12	6000ZZ
		7001HTDBGMP5 (Wrap-around specification)				

Motor Selection

When selecting a motor that is installed on the GL-N model, refer to the following data. For details of the motor selection method and motor specifications, contact the motor manufacturer.

[Ball Screw Specifications]

Actuator model number			Ball screw shaft				
Nominal model number	Base length*1 (mm)	Ball screw	Model number	Outer diameter (mm)	Lead (mm)	Length*2 (mm)	Shaft-end outer diameter (mm)
GL15N	034	B05	BTK1605-2.6ZZ	16	5	311	ø 8h7
	142					1391	
GL15N	034	B10	BLK1510-5.6ZZ	15	10	311	ø 8h7
	142					1391	
GL15N	034	B16	BLK1616-3.6	16	16	311	ø 8h7
	142					1391	
GL15N	034	B20	WTF1520-3ZZ	15	20	311	ø 8h7
	142					1391	
GL15N	034	B30	WTF1530-2ZZ	15	30	311	ø 8h7
	142					1391	
GL20N	046	B05	BTK2005-2.6ZZ	20	5	427	ø 10h7
	178					1747	
GL20N	046	B10	BLK1510-5.6ZZ	15	10	427	ø 10h7
	142					1387	
GL20N	046	B20	BLK2020-3.6ZZ	20	20	427	ø 10h7
	178					1747	
GL20N	046	B40	WTF2040-2ZZ	20	40	427	ø 10h7
	178					1747	

LM Guide model number symbol	Movable section mass (kg)	Sliding resistance (N)
GL15N-***-SV	1.7	16.2
GL15N-***-SW	2.2	16.6
GL15N-***-SWQ	2.4	26.6
GL15N-***-HV	2.2	17.2
GL15N-***-HVQ	2.4	33.2
GL20N-***-SV	2.7	21.0
GL20N-***-SW	3.2	21.4
GL20N-***-SWQ	3.4	33.4
GL20N-***-HV	3.6	20.6
GL20N-***-HVQ	3.8	36.6

Timing pulley	
Nominal model number	Moment of inertia (kg-cm ²)
GL15N	0.12
GL20N	0.12

Allowable input torque*3	
Nominal model number	(N-m)
GL15N	2.8
GL20N	5.3

*1 The base length shows the minimum and maximum lengths.

Example: 034 for a base length of 340mm and 142 for a base length of 1420mm

*2 The length of a ball screw shaft is the length available for the direct-mounting specification. For the wrap-around specification, the length of the ball screw shaft is 74mm longer for the GL15N model and 78mm longer for the GL20N model.

*3 The allowable input torque is the value for the direct-mounting specification. For the wrap-around specification, contact THK.

[Belt Specifications]

Actuator model number		Belt		Timing pulley			
Nominal model number	Timing belt	Model number	Mass* (kg)	Model number	Diameter (PCD) (mm)	Table moving distance/one turn of pulley	Moment of inertia (total of two pulleys) (kg-cm ²)
GL15N	EH	025-MA5	0.38	22-MA5-025	35.01	110 mm	0.289
GL20N	EH	025-MA5	0.58	24-MA5-025	38.20	120 mm	0.447

Reducer		
Reduction ratio	Rated output (W)	Moment of inertia (kg-cm ²)
1/3	100	0.058
1/3	200	0.135
1/5	100	0.04
1/5	200	0.118
1/9	100	0.035

Allowable input torque	
Nominal model number	(N-m)
GL15N	4.8
GL20N	8.1

LM Guide model number symbol	Movable section mass (kg)	Sliding resistance (N)
GL15N-***-SV	1.2	16.2
GL15N-***-SW	1.7	16.6
GL15N-***-SWQ	1.8	26.6
GL15N-***-HV	1.7	17.2
GL15N-***-HVQ	1.8	33.2
GL20N-***-SV	2.1	21.0
GL20N-***-SW	2.6	21.4
GL20N-***-SWQ	2.8	33.4
GL20N-***-HV	3.0	20.6
GL20N-***-HVQ	3.2	36.6

* The belt mass is the mass for the maximum belt length.

Precautions on Use

Handling

- Disassembling parts may cause foreign material to enter the system or deteriorate the accuracy. Do not disassemble the product.
- Do not drop or strike this product. Doing so may damage the product. If this product is a shocked, its functions may be damaged even though it looks normal in appearance.
- Entrance of foreign material may cause damage to the ball circulating component or functional loss. Prevent foreign material, such as dust or cutting chips, from entering the system.
- When planning to use the LM system in an environment where the coolant penetrates the LM Actuator model GL-N, it may cause trouble to product functions depending on the type of the coolant. Contact THK for details.
- Exceeding the permissible rotational speed may lead the components to be damaged or cause an accident. Be sure to use the product within the specification range designated by THK.
- The service temperature range of this product is 0 to 40°C (no freezing or condensation). If you consider using this product outside the service temperature range, contact THK.
- When using the LM system in locations exposed to constant vibrations or in special environments such as clean rooms, vacuum and low/high temperature, contact THK in advance.
- If the product is operating or in the ready state, never touch a moving part. In addition, do not enter the operating area of the actuator.
- If two or more people are involved in the operation, confirm the procedures such as a sequence, signs and anomalies in advance, and appoint another person for monitoring the operation.

Lubrication

- Thoroughly remove anti-rust oil and feed lubricant before using the product.
- To maximize the performance of the LM Actuator model GL-N, lubrication is required. Using the product without lubrication may increase wear of the rolling elements or shorten the service life. This product contains THK AFB-LF grease as standard.
- The ball screw does not have a grease nipple, apply grease directly onto the rolling surface.
- Do not mix lubricants of different physical properties.
- When planning to use a special lubricant, contact THK before using it.
- When planning to use an oil lubricant, contact THK before using it.
- In normal use, the lubricant must be replenished every 100 km as a guide. However, the greasing interval varies according to the conditions. We recommend determining the greasing interval based on the result of the initial inspection.
- In locations exposed to constant vibrations or in special environments such as clean rooms, vacuum and low/high temperature, normal lubricants may not be used. Contact THK for details. For clean room applications, low dust-generative grease is available. Contact THK for details.

Storage

When storing the LM Actuator model GL-N, enclose it in a package designated by THK and store it in a horizontal orientation while avoiding high temperature, low temperature and high humidity.

- “LM GUIDE,” and “” are registered trademarks of THK CO., LTD.
- The actual products may differ from the pictures and photographs in this catalog.
- Outward appearances and specifications is subject to change without notification for purposes of improvement, please inquire before using them.
- Although great care has been taken in the production of this catalog, THK will not take any responsibility for damage resulting from typographical errors or omissions.
- In exporting our products and technology, or selling them for the purpose of export, THK has a basic policy of observing laws relating to foreign exchange, trade and other laws. For export of THK products as single items, contact THK in advance.

All rights reserved

THK CO., LTD.

HEAD OFFICE 3-11-6, NISHI-GOTANDA, SHINAGAWA-KU, TOKYO 141-8503 JAPAN
INTERNATIONAL SALES DEPARTMENT PHONE:+81-3-5434-0351 FAX:+81-3-5434-0353
Global site : <http://www.thk.com/>

NORTH AMERICA

THK America, Inc.
● HEADQUARTERS
Phone:+1-847-310-1111 Fax:+1-847-310-1271
● CHICAGO OFFICE
Phone:+1-847-310-1111 Fax:+1-847-310-1182
● NORTH EAST OFFICE
Phone:+1-845-369-4035 Fax:+1-845-369-4909
● ATLANTA OFFICE
Phone:+1-770-840-7990 Fax:+1-770-840-7897
● LOS ANGELES OFFICE
Phone:+1-949-955-3145 Fax:+1-949-955-3149
● SAN FRANCISCO OFFICE
Phone:+1-925-455-8948 Fax:+1-925-455-8965
● DETROIT OFFICE
Phone:+1-248-858-9330 Fax:+1-248-858-9455
● TORONTO OFFICE
Phone:+1-905-820-7800 Fax:+1-905-820-7811

SOUTH AMERICA

THK Brasil LTDA
Phone:+55-11-3767-0100 Fax:+55-11-3767-0101

EUROPE

THK GmbH
● EUROPEAN HEADQUARTERS
Phone:+49-2102-7425-555 Fax:+49-2102-7425-556
● DÜSSELDORF OFFICE
Phone:+49-2102-7425-0 Fax:+49-2102-7425-299

FRANKFURT OFFICE

Phone:+49-2102-7425-650 Fax:+49-2102-7425-699
● STUTTGART OFFICE
Phone:+49-7150-9199-0 Fax:+49-7150-9199-888
● MÜNCHEN OFFICE
Phone:+49-8937-0616-0 Fax:+49-8937-0616-26
● U.K. OFFICE
Phone:+44-1908-30-3050 Fax:+44-1908-30-3070
● ITALY MILANO OFFICE
Phone:+39-039-284-2079 Fax:+39-039-284-2527
● ITALY BOLOGNA OFFICE
Phone:+39-051-641-2211 Fax:+39-051-641-2230
● SWEDEN OFFICE
Phone:+46-8-445-7630 Fax:+46-8-445-7639
● AUSTRIA OFFICE
Phone:+43-7229-51400 Fax:+43-7229-51400-79
● SPAIN OFFICE
Phone:+34-93-652-5740 Fax:+34-93-652-5746
● TURKEY OFFICE
Phone:+90-216-362-4050 Fax:+90-216-362-4050
● PRAGUE OFFICE
Phone:+420-2-41025-100 Fax:+420-2-41025-199
● MOSCOW OFFICE
Phone:+7-495-649-80-47 Fax:+7-495-649-80-44
THK Europe B.V.
● EINDHOVEN OFFICE
Phone:+31-040-290-9500 Fax:+31-040-290-9599
THK France S.A.S.
Phone:+33-4-3749-1400 Fax:+33-4-3749-1401

CHINA

THK (CHINA) CO., LTD.
● HEADQUARTERS
Phone:+86-411-8733-7111 Fax:+86-411-8733-7000
● SHANGHAI OFFICE
Phone:+86-21-6219-3000 Fax:+86-21-6219-9890
● BEIJING OFFICE
Phone:+86-10-8441-7277 Fax:+86-10-6590-3557
● CHENGDU OFFICE
Phone:+86-28-8526-8025 Fax:+86-28-8525-6357
● GUANGZHOU OFFICE
Phone:+86-20-8523-8418 Fax:+86-20-3801-0456
THK (SHANGHAI) CO., LTD.
Phone:+86-21-6275-5280 Fax:+86-21-6219-9890

TAIWAN

THK TAIWAN CO., LTD.
● TAIPEI HEAD OFFICE
Phone:+886-2-2888-3818 Fax:+886-2-2888-3819
● TAICHUNG OFFICE
Phone:+886-4-2359-1505 Fax:+886-4-2359-1506
● TAINAN OFFICE
Phone:+886-6-289-7668 Fax:+886-6-289-7669

KOREA

SEOUL REPRESENTATIVE OFFICE
Phone:+82-2-3468-4351 Fax:+82-2-3468-4353

SINGAPORE

THK LM SYSTEM Pte. Ltd.
Phone:+65-6884-5500 Fax:+65-6884-5550

INDIA

BANGALORE REPRESENTATIVE OFFICE
Phone:+91-80-2330-1524 Fax:+91-80-2314-8226