



# WPLN

## The versatile right angle gearbox with spiral gearing for a quiet drive

Thanks to its spiral teeth, our **WPLN** achieves the optimal synchronism for the best surface qualities. By minimizing vibrations, it runs uniformly and quietly. The precision right angle planetary gearbox features lifetime lubrication and can be mounted virtually anywhere.

Nominal output torque **22 - 800 Nm**



Radial force **3200 - 12500 N**



Axial force **4300 - 15000 N**



Torsional backlash **3 - 5 arcmin**



Protection class **IP65**



Frame sizes

- 70
- 90
- 115
- 142

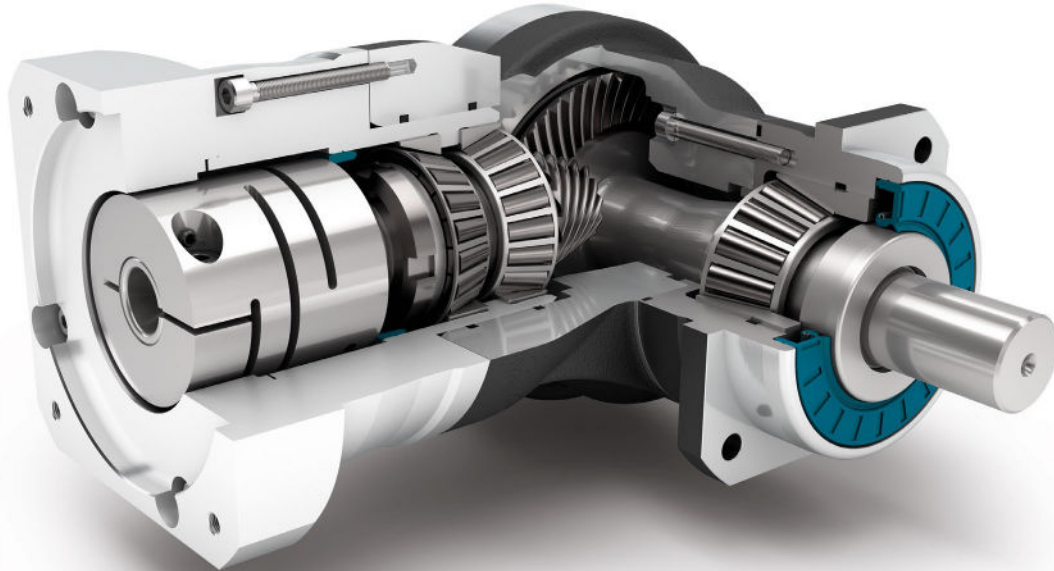

Precision Line



Counterdirectional rotation



Square type output flange



Rotary shaft seal



Option: Reduced backlash (2-stage)



Right angle gearbox



Hypoid gear right angle stage



Preloaded tapered roller bearings



Extra long centering collar



Option: Planetary gearbox with mounted pinion on page 140

Detailed explanations of the technical features starting on page 169.

Code	Gearbox characteristics			WPLN070	WPLN090	WPLN115	WPLN142	p <sup>(1)</sup>	
	Service life (L <sub>10h</sub> )	t <sub>L</sub>	h	20,000					
	Service life at T <sub>2N</sub> x 0,88			30,000					
	Efficiency at full load <sup>(2)</sup>	η	%	95				1	
				94				2	
	Min. operating temperature	T <sub>min</sub>	°C (°F)	-25 (-13)					
	Max. operating temperature	T <sub>max</sub>		90 (194)					
	Protection class	IP65							
<b>S</b>	Standard lubrication	Oil (lifetime lubrication)							
<b>F</b>	Food grade lubrication	Oil (lifetime lubrication)							
	Installation position	Any							
<b>S</b>	Standard backlash	< 5							
<b>R</b>	Reduced backlash	j <sub>t</sub>	arcmin	-				1	
				< 3				2	
	Torsional stiffness <sup>(2)</sup>	c <sub>g</sub>	Nm /arcmin (lb <sub>f</sub> .in/ arcmin)	1.8 - 3.1 (16 - 27)	4.6 - 7.0 (41 - 62)	8.6 - 13.5 (76 - 119)	24.5 - 34.0 (217 - 301)	1	
				2.3 - 3.6 (20 - 32)	5.9 - 8.6 (52 - 76)	11.3 - 16.9 (100 - 150)	31.5 - 42.5 (279 - 376)	2	
	Gearbox weight <sup>(2)</sup>	m <sub>G</sub>	kg (lb <sub>m</sub> )	3.4 (7.5)	5.4 - 5.9 (12.0 - 12.9)	11.3 (24.9)	25.9 - 26.5 (57.2 - 58.4)	1	
				4.4 - 4.5 (9.7 - 9.8)	5.8 - 5.9 (12.7 - 13.0)	10.4 - 10.7 (22.8 - 23.5)	24.6 - 25.2 (54.3 - 55.5)	2	
<b>S</b>	Standard surface	Right angle housing: Aluminum – anodized (black)							
	Running noise <sup>(3)</sup>	Q <sub>g</sub>	dB(A)	66	67	68	70		
	Max. bending moment based on the gearbox input flange <sup>(4)</sup>	M <sub>b</sub>	Nm (lb <sub>f</sub> .in)	12 (106)	25.5 (226)	53 (469)	120 (1062)	1	
				12 (106)	12 (106)	25.5 (226)	53 (469)	2	

Output shaft loads				WPLN070	WPLN090	WPLN115	WPLN142	p <sup>(1)</sup>
Radial force for 20,000 h <sup>(5)(6)</sup>	F <sub>r20.000h</sub>			3200 (719)	5200 (1169)	6000 (1349)	12500 (2810)	1
				3200 (719)	5500 (1236)	6000 (1349)	12500 (2810)	2
Axial force for 20,000 h <sup>(5)(6)</sup>	F <sub>a20.000h</sub>			4300 (967)	5900 (1326)	7000 (1574)	14500 (3260)	1
				4400 (989)	6400 (1439)	8000 (1798)	15000 (3372)	2
Radial force for 30,000 h <sup>(5)(6)</sup>	F <sub>r30.000h</sub>			3200 (719)	5200 (1169)	6000 (1349)	10900 (2450)	1
				3200 (719)	4800 (1079)	5400 (1214)	11400 (2563)	2
Axial force for 30,000 h <sup>(5)(6)</sup>	F <sub>a30.000h</sub>			3700 (832)	5200 (1169)	6100 (1371)	12000 (2698)	1
				3900 (877)	5700 (1281)	7000 (1574)	13200 (2967)	2
Maximum radial force <sup>(6)(7)</sup>	F <sub>rStat</sub>			3200 (719)	5200 (1169)	6000 (1349)	12500 (2810)	1
				3200 (719)	5500 (1236)	6000 (1349)	12500 (2810)	2
Maximum axial force <sup>(6)(7)</sup>	F <sub>aStat</sub>			4300 (967)	5900 (1326)	7000 (1574)	14500 (3260)	1
				4400 (989)	6400 (1439)	8000 (1798)	15000 (3372)	2
Tilting moment for 20,000 h <sup>(5)(7)</sup>	M <sub>K20.000h</sub>			322 (2850)	624 (5523)	1010 (8939)	2225 (19693)	1
				322 (2850)	660 (5841)	1010 (8939)	2225 (19693)	2
Tilting moment for 30,000 h <sup>(5)(7)</sup>	M <sub>K30.000h</sub>			322 (2850)	624 (5523)	1010 (8939)	1940 (17170)	1
				322 (2850)	576 (5098)	909 (8045)	2029 (17958)	2

Moment of inertia				WPLN070	WPLN090	WPLN115	WPLN142	p <sup>(1)</sup>
Mass moment of inertia <sup>(2)</sup>	J	kgcm <sup>2</sup> (lb <sub>f</sub> .in.s <sup>2</sup> 10 <sup>-4</sup> )		0.500 - 0.658 (4.425 - 5.824)	1.013 - 1.387 (8.966 - 12.276)	4.767 - 5.875 (42.192 - 51.998)	15.090 - 20.883 (133.558 - 184.830)	1
				0.498 - 0.642 (4.408 - 5.682)	0.497 - 0.649 (4.399 - 5.744)	1.014 - 1.419 (8.975 - 12.559)	4.807 - 6.387 (42.546 - 56.530)	2

(1) Number of stages  
 (2) The ratio-dependent values can be retrieved in Tec Data Finder – www.neugart.com  
 (3) Sound pressure level from 1 m, measured on input running at n<sub>i</sub>=3000 rpm no load; i=5  
 (4) Max. motor weight\* in kg = 0.2 x M<sub>g</sub> / motor length in m  
 \* with symmetrically distributed motor weight  
 \* with horizontal and stationary mounting  
 (5) These values are based on an output shaft speed of n<sub>2</sub>=100 rpm  
 (6) Based on center of output shaft  
 (7) Other (sometimes higher) values following changes to T<sub>2N</sub>, F<sub>r</sub>, F<sub>a</sub>, cycle, and service life of bearing. Application specific configuration with NCP – www.neugart.com

Output torques			WPLN070	WPLN090	WPLN115	WPLN142	i <sup>(1)</sup>	p <sup>(2)</sup>
Nominal output torque <sup>(3)(4)</sup>	T <sub>2N</sub>	Nm (lb <sub>r</sub> .in)	45 (398)	90 (797)	160 (1416)	320 (2832)	4	1
			42 (372)	75 (664)	140 (1239)	280 (2478)	5	
			28 (248)	51 (451)	91 (805)	189 (1673)	7	
			27 (239)	50 (443)	90 (797)	180 (1593)	8	
			22 (195)	40 (354)	75 (664)	160 (1416)	10	
			77 (682)	150 (1328)	300 (2655)	640 (5664)	16	2
			77 (682)	150 (1328)	300 (2655)	800 (7081)	20	
			65 (575)	140 (1239)	260 (2301)	700 (6196)	25	
			60 (531)	112 (991)	204 (1806)	364 (3222)	28	
			77 (682)	108 (956)	200 (1770)	360 (3186)	32	
			65 (575)	140 (1239)	255 (2257)	455 (4027)	35	
			65 (575)	135 (1195)	250 (2213)	450 (3983)	40	
			65 (575)	110 (974)	200 (1770)	375 (3319)	50	
			40 (354)	80 (708)	150 (1328)	450 (3983)	64	
27 (239)	60 (531)	125 (1106)	305 (2699)	100				
Max. output torque <sup>(4)(5)</sup>	T <sub>2max</sub>	Nm (lb <sub>r</sub> .in)	72 (637)	144 (1275)	256 (2266)	512 (4532)	4	1
			67 (593)	120 (1062)	224 (1983)	448 (3965)	5	
			45 (398)	82 (726)	145 (1283)	302 (2673)	7	
			43 (381)	80 (708)	144 (1275)	288 (2549)	8	
			35 (310)	64 (566)	120 (1062)	256 (2266)	10	
			123 (1089)	240 (2124)	480 (4248)	1024 (9063)	16	2
			123 (1089)	240 (2124)	480 (4248)	1280 (11329)	20	
			104 (920)	224 (1983)	416 (3682)	1120 (9913)	25	
			96 (850)	180 (1593)	328 (2903)	580 (5133)	28	
			123 (1089)	172 (1522)	320 (2832)	576 (5098)	32	
			104 (920)	224 (1983)	410 (3629)	725 (6417)	35	
			104 (920)	216 (1912)	400 (3540)	720 (6373)	40	
			104 (920)	176 (1558)	320 (2832)	600 (5310)	50	
			64 (566)	128 (1133)	240 (2124)	720 (6373)	64	
43 (381)	96 (850)	200 (1770)	488 (4319)	100				

(1) Ratios (i=n<sub>1</sub>/n<sub>2</sub>)  
 (2) Number of stages  
 (3) Application specific configuration with NCP – www.neugart.com  
 (4) Values for feather key (code "A"): for repeated load  
 (5) 30,000 rotations of the output shaft permitted; see page 158

Output torques			WPLN070	WPLN090	WPLN115	WPLN142	$i^{(1)}$	$p^{(2)}$
Emergency stop torque <sup>(3)</sup>	$T_{2Stop}$	Nm (lb <sub>f</sub> .in)	100 (885)	200 (1770)	400 (3540)	800 (7081)	4	1
			100 (885)	200 (1770)	400 (3540)	800 (7081)	5	
			75 (664)	150 (1328)	300 (2655)	700 (6196)	7	
			75 (664)	150 (1328)	300 (2655)	700 (6196)	8	
			75 (664)	150 (1328)	300 (2655)	700 (6196)	10	
			150 (1328)	300 (2655)	650 (5753)	1600 (14161)	16	
		150 (1328)	300 (2655)	650 (5753)	1600 (14161)	20	2	
		150 (1328)	300 (2655)	650 (5753)	1600 (14161)	25		
		120 (1062)	280 (2478)	600 (5310)	1200 (10621)	28		
		150 (1328)	300 (2655)	600 (5310)	1200 (10621)	32		
		130 (1151)	280 (2478)	650 (5753)	1500 (13276)	35		
		150 (1328)	300 (2655)	650 (5753)	1500 (13276)	40		
		150 (1328)	300 (2655)	600 (5310)	1200 (10621)	50		
		80 (708)	200 (1770)	380 (3363)	1000 (8851)	64		
80 (708)	200 (1770)	480 (4248)	750 (6638)	100				

Input speeds			WPLN070	WPLN090	WPLN115	WPLN142	$i^{(1)}$	$p^{(2)}$
Average thermal input speed at $T_{2N}$ and S1 <sup>(4)(5)</sup>	$n_{1N}$	rpm	1800 <sup>(6)</sup>	1650 <sup>(6)</sup>	1150 <sup>(6)</sup>	950 <sup>(6)</sup>	4	1
			2000 <sup>(6)</sup>	1900 <sup>(6)</sup>	1250 <sup>(6)</sup>	1000 <sup>(6)</sup>	5	
			2350 <sup>(6)</sup>	2250 <sup>(6)</sup>	1400 <sup>(6)</sup>	1200 <sup>(6)</sup>	7	
			2350 <sup>(6)</sup>	2250 <sup>(6)</sup>	1450 <sup>(6)</sup>	1200 <sup>(6)</sup>	8	
			2500 <sup>(6)</sup>	2400 <sup>(6)</sup>	1500 <sup>(6)</sup>	1300 <sup>(6)</sup>	10	
			1850 <sup>(6)</sup>	1800 <sup>(6)</sup>	1650 <sup>(6)</sup>	1000 <sup>(6)</sup>	16	
		2000 <sup>(6)</sup>	2100 <sup>(6)</sup>	1950 <sup>(6)</sup>	1050 <sup>(6)</sup>	20	2	
		2150 <sup>(6)</sup>	2250 <sup>(6)</sup>	2150 <sup>(6)</sup>	1150 <sup>(6)</sup>	25		
		2200 <sup>(6)</sup>	2250 <sup>(6)</sup>	2150 <sup>(6)</sup>	1400 <sup>(6)</sup>	28		
		2300 <sup>(6)</sup>	2300 <sup>(6)</sup>	2200 <sup>(6)</sup>	1400 <sup>(6)</sup>	32		
		2350 <sup>(6)</sup>	2300 <sup>(6)</sup>	2200 <sup>(6)</sup>	1400 <sup>(6)</sup>	35		
		2400 <sup>(6)</sup>	2300 <sup>(6)</sup>	2250 <sup>(6)</sup>	1450 <sup>(6)</sup>	40		
		2500 <sup>(6)</sup>	2450 <sup>(6)</sup>	2400 <sup>(6)</sup>	1550 <sup>(6)</sup>	50		
		2600 <sup>(6)</sup>	2950 <sup>(6)</sup>	2850 <sup>(6)</sup>	1750 <sup>(6)</sup>	64		
2700 <sup>(6)</sup>	3100 <sup>(6)</sup>	3050 <sup>(6)</sup>	1900 <sup>(6)</sup>	100				
Max. mechanical input speed <sup>(4)</sup>	$n_{1Limit}$	rpm	16000	14000	9500	8000		1
			16000	16000	14000	9500		2

(1) Ratios ( $i=n_1/n_2$ )  
 (2) Number of stages  
 (3) Permitted 1000 times  
 (4) Application-specific speed configurations with NCP – [www.neugart.com](http://www.neugart.com)  
 (5) See page 158 for the definition  
 (6) Average thermal input speed at 50%  $T_{2N}$  and S1

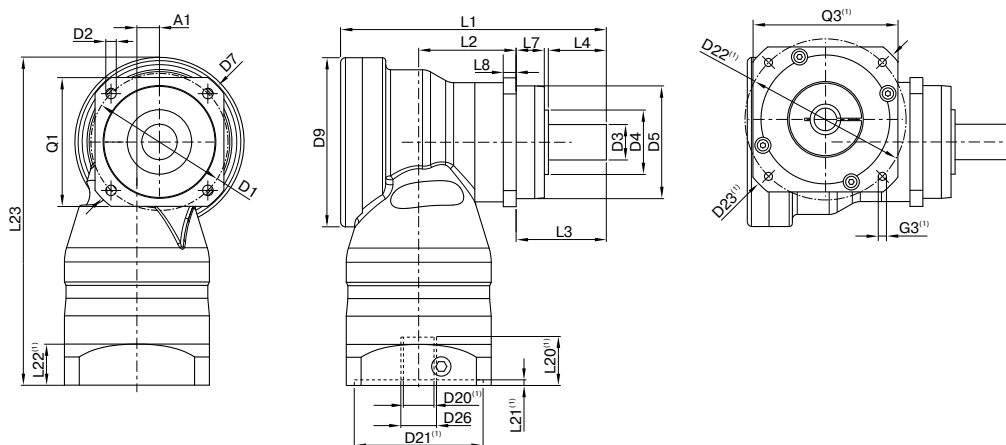

Drawing corresponds to a WPLN090 / 1-stage / smooth output shaft / 19 mm clamping system / motor adaptation – 2-part – round universal flange / B5 flange type motor

<sup>(1)</sup> The dimensions vary with the motor/gearbox flange. The input flange dimensions can be retrieved for each specific motor in Tec Data Finder at [www.neugart.com](http://www.neugart.com)

Geometry <sup>(2)</sup>			WPLN070	WPLN090	WPLN115	WPLN142	p <sup>(3)</sup>	Code
Axis offset	A1		10 (0.394)	14 (0.551)	20 (0.787)	26 (1.024)	1	
			10 (0.394)	10 (0.394)	14 (0.551)	20 (0.787)	2	
Pitch circle diameter output	D1		68 - 75 (2.677 - 2.953)	85 (3.346)	120 (4.724)	165 (6.496)		
Mounting bore output	D2	4x	5.5 (0.217)	6.5 (0.256)	9.0 (0.354)	11.0 (0.433)		
Shaft diameter output	D3	k6	16 (0.630)	22 (0.866)	32 (1.260)	40 (1.575)		
Shaft collar output	D4		30 (1.181)	40 (1.575)	45 (1.772)	70 (2.756)	1	
			35 (1.378)	40 (1.575)	45 (1.772)	70 (2.756)	2	
Centering diameter output	D5	g7	60 (2.362)	70 (2.756)	90 (3.543)	130 (5.118)		
Diagonal dimension output	D7		92 (3.622)	100 (3.937)	140 (5.512)	185 (7.283)		
Max. diameter	D9		86 (3.386)	105 (4.134)	120 (4.724)	170 (6.693)	1	
			86 (3.386)	86 (3.386)	105 (4.134)	120 (4.724)	2	
Flange cross section output	Q1	■	70 (2.756)	80 (3.150)	110 (4.331)	142 (5.591)		
Total length	L1		137.5 (5.413)	165 (6.496)	218 (8.583)	273 (10.748)	1	
			185 (7.283)	207 (8.150)	248.5 (9.783)	342.5 (13.484)	2	
Housing length	L2		46.5 (1.831)	60.5 (2.382)	73.5 (2.894)	76 (2.992)	1	
			94 (3.701)	108 (4.252)	112 (4.409)	176 (6.929)	2	
Shaft length output	L3		48 (1.890)	56 (2.205)	88 (3.465)	110 (4.331)		
Centering depth output	L7		18 (0.709)	17.5 (0.689)	28 (1.102)	28 (1.102)	1	
			19 (0.748)	17.5 (0.689)	28 (1.102)	28 (1.102)	2	
Flange thickness output	L8		7 (0.276)	8 (0.315)	10 (0.394)	12 (0.472)		
Offset length	L9		43 (1.693)	48.5 (1.909)	56.5 (2.224)	87 (3.425)	1	
			43 (1.693)	43 (1.693)	48.5 (1.909)	56.5 (2.224)	2	
Min. overall height	L23		179.0 (7.047)	203.5 (8.012)	247.5 (9.744)	318.0 (12.520)	1	
			179.0 (7.047)	182.5 (7.185)	210.0 (8.268)	258.5 (10.177)	2	
Motor shaft diameter j6/k6	D20		More information on page 155/156					
Clamping system diameter input	D26		More information on page 155/156					
Output shaft with feather key (DIN 6885-1)			A 5x5x25	A 6x6x28	A 10x8x50	A 12x8x65		A
Feather key width (DIN 6885-1)	B1		5 (0.197)	6 (0.236)	10 (0.394)	12 (0.472)		
Shaft height including feather key (DIN 6885-1)	H1		18 (0.709)	24,5 (0.965)	35 (1.378)	43 (1.693)		
Shaft length from shoulder	L4		28 (1.102)	36 (1.417)	58 (2.283)	80 (3.150)		
Feather key length	L5		25 (0.984)	28 (1.102)	50 (1.969)	65 (2.559)		
Distance from shaft end	L6		2 (0.079)	4 (0.157)	4 (0.157)	8 (0.315)		
Center hole (DIN 332, type DR)	C		M5x12,5	M8x19	M12x28	M16x36		
Smooth output shaft								B
Shaft length from shoulder	L4		28 (1.102)	36 (1.417)	58 (2.283)	80 (3.150)		
Splined output shaft (DIN 5480)			W16x0,8 x18x6m	W22x1,25 x16x6m	W32x1,25 x24x6m	W40x2,0 x18x6m		C
Width of gearing	L <sub>v</sub>		15 (0.591)	15 (0.591)	15 (0.591)	20 (0.787)		
Shaft collar output	L3		48 (1.890)	56 (2.205)	88 (3.465)	110 (4.331)		
Shaft length from shoulder	L4		28 (1.102)	36 (1.417)	58 (2.283)	80 (3.150)		
Center hole (DIN 332, type DR)	C		M5x12,5	M8x19	M12x28	M16x36		

<sup>(2)</sup> Dimensions in mm

<sup>(3)</sup> Number of stages