

IMA-S

HYGIENIC INTEGRATED SERVO ACTUATOR

ENDURANCE TECHNOLOGYSM
A Tolomatic Design Principle
Patented



Designed for the most demanding food & beverage applications

The IMA-S is a hygienically designed integrated servo actuator for the food and beverage processing industry. The IP69K hygienic design features including 316 stainless steel construction, allows for open machine designs and clean-in-place compatibility.









The IMA-S's unique hygienic integrated design

Features:

- Prevents bacterial growth
- Resists corrosion
- Provides IP69K wash-down protection
- Improves performance, flexibility, and efficiency

TOLOMATIC'S ELECTRIC ROD-STYLE ACTUATORS

	ERD	RSH	RSA	RSX	GSA	IMA
						
	Rod-Style Actuator	Hygienic Rod-Style Actuator	Rod-Style Actuator	Rod-Style Actuator	Guided Rod-Style Actuator	Integrated Servo Actuator
Force up to:	2.22 kN <i>(500 lbf)</i>	35 kN <i>(7,943 lbf)</i>	58 kN <i>(13,039 lbf)</i>	222.4 kN <i>(50,000 lbf)</i>	4.23 kN <i>(950 lbf)</i>	30.6 kN <i>(6,875 lbf)</i>
Speed up to:	1,016 mm/sec <i>(40 in/sec)</i>	498 mm/sec <i>(19.6 in/sec)</i>	3,124 mm/sec <i>(123 in/sec)</i>	760 mm/sec <i>(29.9 in/sec)</i>	3,124 mm/sec <i>(123 in/sec)</i>	1,334 mm/sec <i>(52.5 in/sec)</i>
Stroke Length up to:	609 mm <i>(24 in)</i>	1,219 mm <i>(48 in)</i>	1,524 mm <i>(60 in)</i>	890 mm <i>(35 in)</i>	914 mm <i>(36 in)</i>	457 mm <i>(18 in)</i>
Screw/Nut Type	Solid, Ball & Roller	Ball & Roller	Solid, Ball & Roller	Roller	Solid & Ball	Ball & Roller
<i>For complete information see www.tolomatic.com or literature number:</i>						
Literature Number:	2190-4000	2100-4010	3600-4166	2171-4001	3600-4166	2700-4000

(Not all models deliver maximum values listed, i.e.: Maximum thrust may not be available with maximum speed)

IMA-S - Hygienic Integrated Servo Actuator

Applications

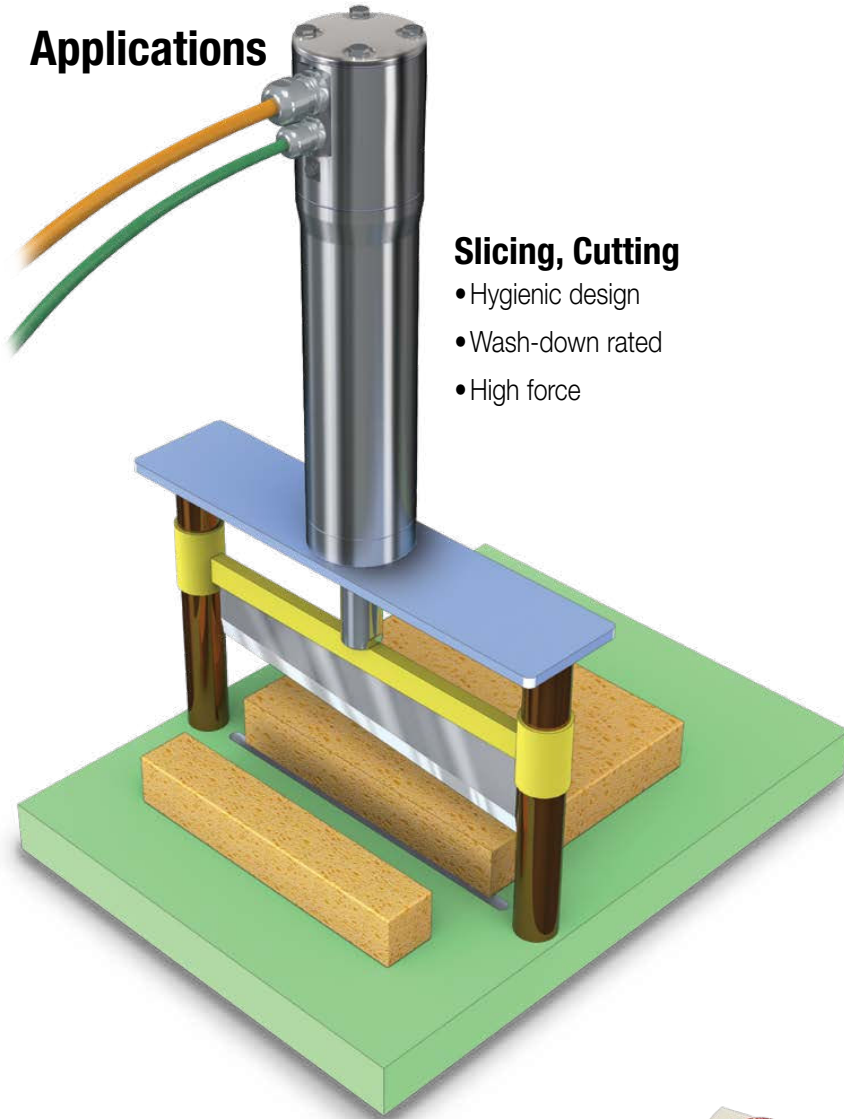

Slicing, Cutting

- Hygienic design
- Wash-down rated
- High force

Volumetric Filling, Pumping & Dispensing

- Repeatable force
- Smooth velocity
- Infinite positioning

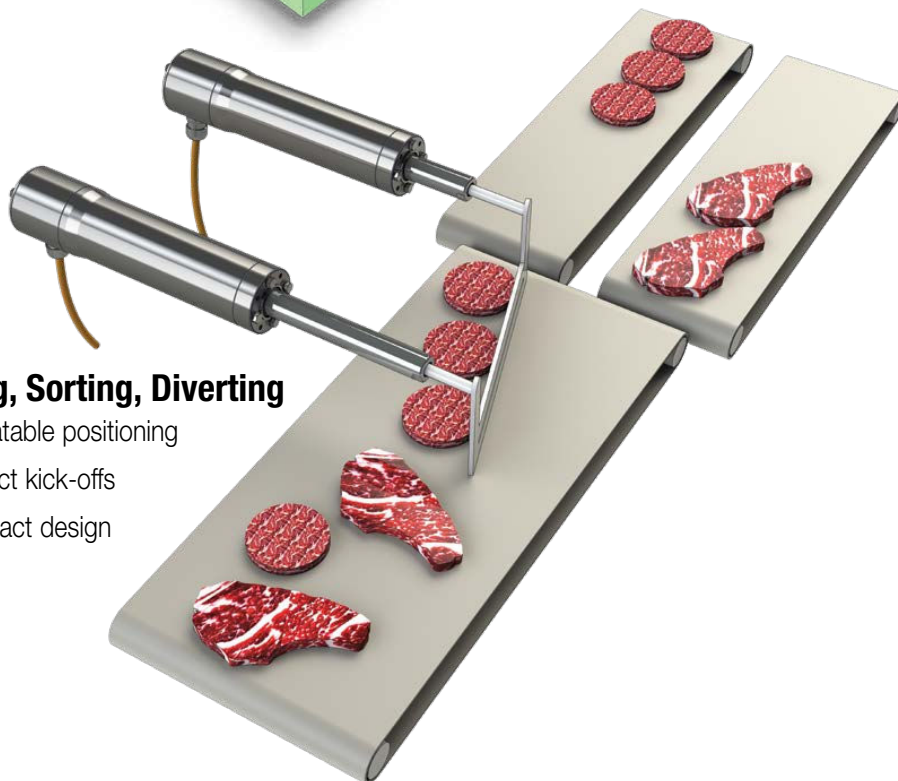

Gating, Sorting, Diverting

- Repeatable positioning
- Product kick-offs
- Compact design



CONTENTS

What is the IMA-S? . . .	2
IMA-S Applications . . .	3
IMA-S Features	4
IMA-S Specs & Performance . . .	6-10
IMA Dimensions . . .	11-12
Selection Guidelines .	13
Application Data Worksheet	14
Ordering	15

IMA-S: HYGIENIC INTEGRATED SERVO ACTUATOR

The IMA-S is a hygienically designed integrated servo actuator for the food and beverage processing industry. The hygienic design features all 316 stainless steel construction, IP69K ingress protection, blue seals/o-rings, and hygienic fasteners/cord grips allowing for open machine designs and clean-in-place compatibility. The product line also includes the IMA-SA model which incorporates an internal anti-rotate feature eliminating the need for an external guidance mechanism making it a perfect actuator for applications such as volumetric filling and pumping.

ENDURANCE TECHNOLOGYSM

A Tolomatic Design Principle

EFFICIENT INTEGRATED MOTOR DESIGN

- Skewed winding minimizes cogging torque for smooth, repeatable motion
- Low electric time constant motor for quick response
- Power dense
- 230 Vac or 460 Vac windings

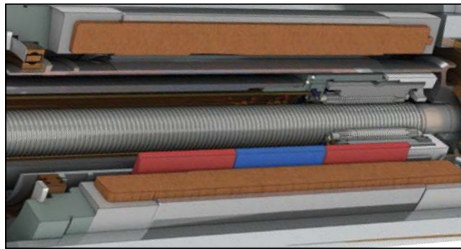

WELDED JOINTS

Welded, polished joints create the most hygienic seam

FOOD GRADE GREASE

- FDA approved grease

HEX FASTENERS

- Stainless steel for corrosion resistance
- Hex head design for fewer particulate collection points



- Hygienic fastener option available

GREASE PORT

- Integrated into rod end for hygienic design
- Screw re-lubrication system via needle zerk extends screw service life

FDA APPROVED SEAL OPTION

- Compliant to FDA standards for human and food contact

FIELD REPLACEABLE SEAL CARTRIDGE

- IP69K rated, wash-down protection
- Clean-in-place compatible
- FDA approved seal cartridge option

M

- Ball screw efficient and economic

- Roller screw the highest longest life

Tolomatic™... MAXIMUM DURABILITY

EXCELLENCE IN MOTION

HIGH RESOLUTION FEEDBACK

OPTIONS:

- Multi-turn absolute encoder, Hiperface, Hiperface DSL, EnDat 2.2
- Resolver
- Incremental encoder

DRIVE/ROBOT CONTROLLER COMPATABILITY

Compatible with the following robot & drive/controller manufacturers:

- Allen Bradley
- Beckhoff
- Bosch Rexroth
- Nidec
- Kollmorgen
- Lenze
- Siemens
- And More

STAINLESS STEEL DESIGN

- 316 Stainless steel construction
- Superior corrosion resistance

HYGIENIC CORD GRIPS

- EHEDG (European Hygienic Engineering and Design Group) cord grip eliminates harborage points

FLEXIBLE FEEDBACK & CABLE OPTIONS



Single (DSL) and dual cable options

BLUE GASKETS & O-RINGS

- Chemically inert
- Wear resistant
- FDA approved

ADDITIONAL OPTIONS

- Brake
- Externally threaded rod end
- Front flange mount
- Rear clevis mount
- Hygienic fasteners
- FDA approved seal cartridge

MULTIPLE SCREW TECHNOLOGIES

... provide motion at an ... price



... provide ... force and ... fe



IMA-SA INTERNAL ANTI-ROTATE OPTION

- Provides hygienic, internal anti-rotate feature, eliminating need for external guidance mechanism
- Often used in volumetric filling and pumping applications

IMA-S - Hygienic Integrated Servo Actuator

Performance & Mechanical Specifications:

SERIES	STACK ¹	NUT/ SCREW	SCREW LEAD	DYNAMIC LOAD RATING (1 MIL REVS)	CONT. FORCE	PEAK FORCE	MAX. VELOCITY	BASE INERTIA ²	INERTIA PER UNIT OF STROKE	BREAK- AWAY TORQUE	NOMINAL BACK DRIVE FORCE ³
			mm	kN	kN	kN	mm/sec	kg-cm ²	kg-cm ² / mm	N-m	N
IMA-ST22	1	BN05	5	5.72	0.45	1.45	355	0.6550	0.00017	0.34	217.95
	3	BN05	5	5.72	1.15	1.45	355	1.2572	0.00017	0.34	217.95
	1	BN10	10	4.40	0.22	1.36	497	0.6643	0.00021	0.34	111.20
	3	BN10	10	4.40	0.57	1.45	497	1.2695	0.00021	0.34	111.20
IMA-ST33	1	BN05	5	8.71	1.19	4.45	304	2.2924	0.00040	0.54	346.94
	3	BN05	5	8.71	3.46	4.45	292	4.4048	0.00040	0.54	346.94
	1	BN10	10	5.40	0.60	2.90	497	2.3138	0.00047	0.54	173.47
	3	BN10	10	5.40	1.73	4.00	497	4.4312	0.00047	0.54	173.47
	1	BN20	20	11.39	0.30	1.45	497	2.5132	0.00156	0.54	88.96
	3	BN20	20	11.39	0.87	3.44	497	4.7137	0.00156	0.54	88.96
	1	RN04	4	41.08	1.30	6.30	243	2.2937	0.00043	0.60	435.90
	3	RN04	4	41.08	3.77	11.12	233	4.4079	0.00043	0.60	435.90
	1	RN05	5	45.42	1.04	5.04	304	2.2968	0.00044	0.60	346.94
	3	RN05	5	45.42	3.02	11.12	292	4.4116	0.00044	0.60	346.94
	1	RN10	10	45.42	0.52	2.52	497	2.3262	0.00054	0.60	173.47
	3	RN10	10	45.42	1.51	5.99	497	4.4488	0.00054	0.60	173.47
IMA-SA33	3	RN04	4	45.42	3.77	11.12	233	4.8199	0.00118	0.72	524.86
	3	RN05	5	45.42	3.02	11.12	292	4.8254	0.00119	0.72	418.11
	3	RN10	10	45.42	1.51	5.99	497	4.8991	0.00132	0.72	209.06

			in	lbf	lbf	lbf	in/sec	lb-in ²	lb-in ² / in	in-lb	lbf
IMA-ST22	1	BN05	0.197	1286	100	325	14.0	0.22383	0.00148	3	49
	3	BN05	0.197	1286	258	325	14.0	0.42960	0.00148	3	49
	1	BN10	0.394	989	50	305	19.6	0.22701	0.00182	3	25
	3	BN10	0.394	989	129	325	19.6	0.43381	0.00182	3	25
IMA-ST33	1	BN05	0.197	1958	269	1000	12.0	0.78337	0.00351	4.8	78
	3	BN05	0.197	1958	779	1000	11.5	1.50519	0.00351	4.8	78
	1	BN10	0.394	1214	134	651	19.6	0.79067	0.00408	4.8	39
	3	BN10	0.394	1214	389	900	19.6	1.51421	0.00408	4.8	39
	1	BN20	0.787	2560	67	326	19.6	0.85882	0.01355	4.8	20
	3	BN20	0.787	2560	195	773	19.6	1.61076	0.01355	4.8	20
	1	RN04	0.157	9236	292	1417	9.6	0.78379	0.00372	5.3	98
	3	RN04	0.157	9236	847	2500	9.2	1.50624	0.00372	5.3	98
	1	RN05	0.197	10211	234	1134	12.0	0.78485	0.00380	5.3	78
	3	RN05	0.197	10211	678	2500	11.5	1.50753	0.00380	5.3	78
	1	RN10	0.394	10211	117	567	19.6	0.79490	0.00468	5.3	39
	3	RN10	0.394	10211	339	1346	19.6	1.52022	0.00468	5.3	39
IMA-SA33	3	RN04	0.157	10211	847	2500	9.2	1.64703	0.01022	6.4	118
	3	RN05	0.197	10211	678	2500	11.5	1.64893	0.01029	6.4	94
	3	RN10	0.394	10211	339	1346	19.6	1.67409	0.01149	6.4	47

¹ Stack winding MV21 / 41
3 Stack winding MV23 / 43

²Value given is for a zero stroke actuator † To be determined, visit www.tolomatic.com for up-to-date information

³In all vertical application an unpowered IMA-S will require a brake to maintain position. Tolomatic recommends that the nominal back drive force specification be used for reference only. Back drive force is subject to change throughout the life of the actuator, due to mechanical break in, ambient temperature, and duty cycle variation.

Reference Only

Back drive force is subject to change throughout the life of the actuator, due to mechanical break in, ambient temperature, and duty cycle variation.



IMA-S - Hygienic Integrated Servo Actuator



sizeit.tolomatic.com
for fast, accurate
actuator selection

Performance & Mechanical Specifications:

		IMA-ST22 (1 STACK, MV21/41)	IMA-ST22 (3 STACK, MV23/43)	IMA-ST33 (1 STACK, MV21/41)	IMA-ST33 (3 STACK, MV23/43)	IMA-SA33
FACE SIZE	mm	64	64	89	89	89
	in	2.52	2.52	3.504	3.504	3.504
STROKE	mm	76.2 to 304.8	152.4 to 304.8	76.2 to 457.2	152.4 to 457.2	0 to 304.8
	in	3.0 to 12.0	6.0 to 12.0	3.0 to 18.0	6.0 to 18.0	0.0 to 12
*BASE WEIGHT	kg	4.8	6.1	10.2	12.5	13.9
	lb	10.5	13.4	22.5	27.5	30.6
WEIGHT PER UNIT OF STROKE	kg/mm	0.0079	0.0079	0.0132	0.0132	0.0173
	lb/in	0.4408	0.4408	0.7390	0.7390	0.9690
SCREW LEAD ACCURACY	BN	mm/300 = 0.051 in/ft = 0.002		(0.004 in/ft for IMA-S33BN20)		
	RN	mm/300 = 0.010 in/ft = 0.0004				
SCREW LEAD BACKLASH	BN	mm = 0.1	in = 0.004			
	RN	mm = 0.051	in = 0.002			
TEMP RANGE	°C	-20 to 40				
	°F	-4 to 104				
IP RATING	IP69K (Static)					
REL. HUMIDITY (NON-CONDENSING)	5 to 90%					
SHOCK	20 gpeak, half sine, 6ms, 3 axis, IEC 60068-2-27					
VIBRATION	2.5 grms, 30-2000 Hz, 3-axis, 1hr, IEC 60068-2-64					

*Value given is for an actuator with minimum stroke, add weight per unit of stroke to calculate weight of entire actuator

Motor Specifications:

		IMA-S22				IMA-S33				IMA-SA33	
WINDING/MOTOR VOLTAGE		MV21	MV41	MV23	MV43	MV21	MV41	MV23	MV43	MV23	MV43
TORQUE CONSTANT (K _t)	N-m/A Peak	0.37	0.75	0.49	0.93	0.61	1.21	0.62	1.21	0.62	1.21
	in-lb/A Peak	3.3	6.6	4.3	8.2	5.4	10.7	5.5	10.7	5.5	10.7
VOLTAGE CONSTANT (K _e)	V/Krpm Peak	51	102	61	122	81	160	79.8	154	79.8	154
CONTINUOUS STALL TORQUE	N-m	0.42	0.42	1.07	1.07	1.12	1.12	3.24	3.24	3.24	3.24
	in-lb	3.7	3.7	9.5	9.5	9.9	9.9	28.7	28.7	28.7	28.7
CONTINUOUS STALL CURRENT	A _{RMS}	0.8	0.4	1.55	0.775	1.3	0.65	3.7	1.85	3.7	1.85
PEAK TORQUE	N-m	2.54	2.54	4.51	4.51	5.42	5.42	13.22	12.88	13.22	12.88
	in-lb	22.5	22.5	39.9	39.9	48	48	117	114	117	114
PEAK CURRENT	A _{RMS}	4.8	2.4	6.6	3.45	6.3	3.3	15	7.5	15	7.5
RESISTANCE	Ohms	18.1	72.4	7.1	28.3	10	40.1	2.07	8.3	2.07	8.3
INDUCTANCE	mH	10.7	42	4.5	18	13.6	54.1	3.8	15	3.8	15
BUS VOLTAGE	V _{RMS}	230	460	230	460	230	460	230	460	230	460
SPEED @ RATED V	RPM	4,264				3,650		3,500		3,500	
NO. OF POLES		8									

RoHS Compliant Components;



Performance data was validated using an aluminum face mount plate: IMA22/33 (8.25" x 7.0" x 0.7");

Ambient Temperature = 77°F (25°C); Elevation < 3281' (1,000 m); Drive specifications: Sinusoidal Commutation and PWM Voltage Source

IMA-S - Hygienic Integrated Servo Actuator

CRITICAL SPEED

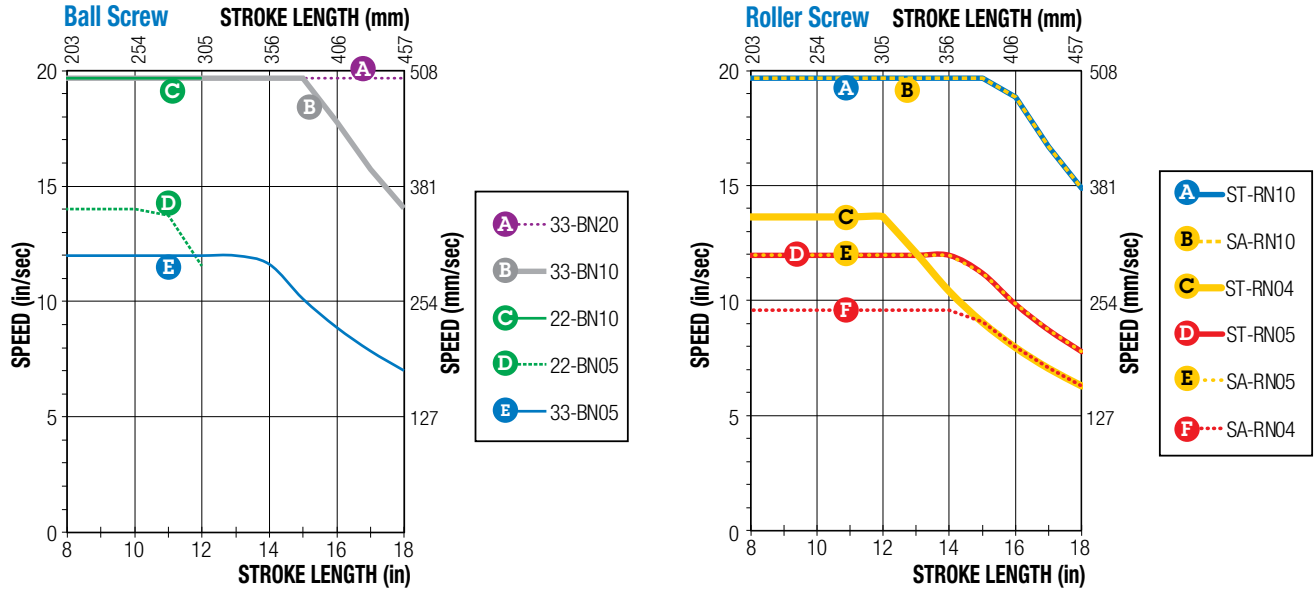

All curves represent properly lubricated and maintained actuators.

ROLLER SCREW BUCKLING LOAD

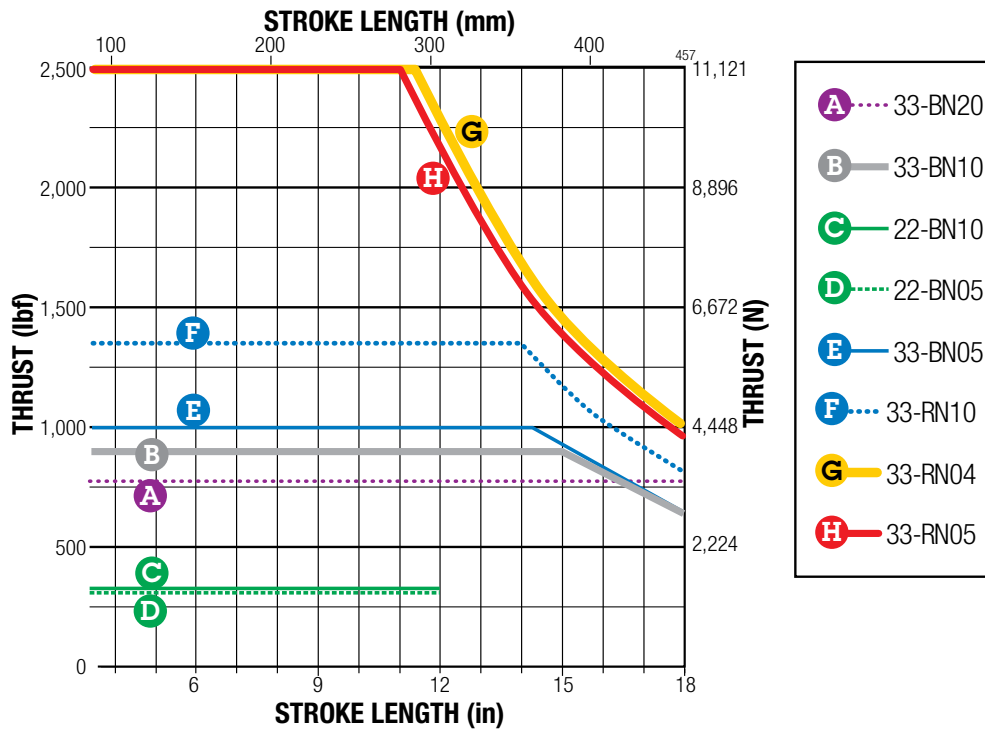

All curves represent properly lubricated and maintained actuators.

LIFE

BALL SCREW

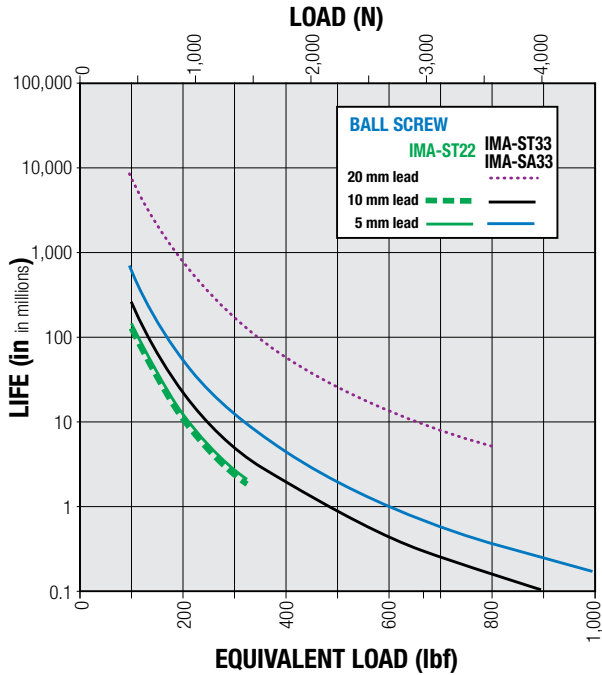

ROLLER SCREW

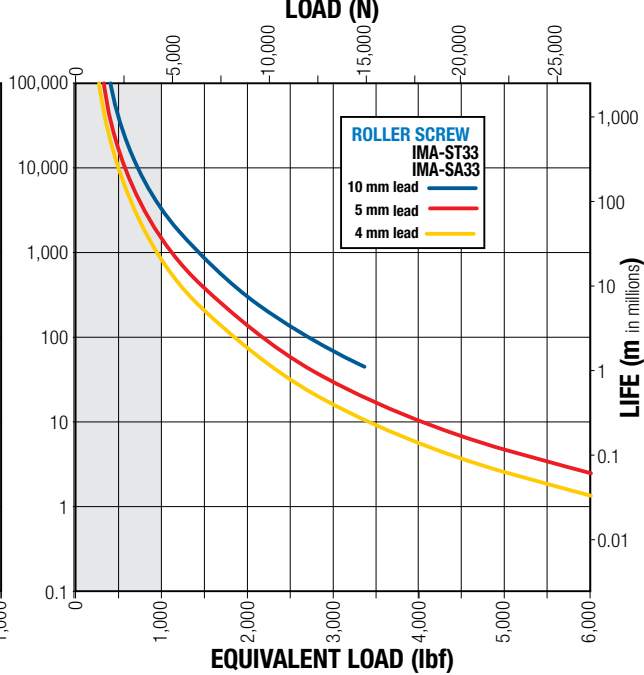

NOTE: The L_{10} expected life of a ball screw linear actuator is expressed as the linear travel distance that 90% of properly maintained ball screw manufactured are expected to meet or exceed. This is not a guarantee and this graph should be used for estimation purposes only.

The underlying formula that defines this value is:

$$L_{10} = \left(\frac{C}{P_e} \right)^3 \cdot \ell \equiv$$

L_{10} Travel life in millions of units (in or mm), where:

- C** = Dynamic load rating (lbf) or (N)
- P_e** = Equivalent load (lbf) or (N)
If load is constant across all movements then:
actual load = equivalent load
- ℓ** = Screw lead (in/rev) (mm/rev)

Use the "Equivalent Load" calculation below, when the load is not constant throughout the entire stroke. In cases where there is only minor variation in loading, use greatest load for life calculations.

Where:

$$P_e = \sqrt[3]{\frac{L_1(P_1)^3 + L_2(P_2)^3 + L_3(P_3)^3 + L_n(P_n)^3}{L}}$$

- P_e** = Equivalent load (lbf) or (N)
- P_n** = Each increment at different load (lbf) or (N)
- L** = Total distanced traveled per cycle (extend + retract stroke)
[$L = L_1 + L_2 + L_3 + L_n$]
- L_n** = Each increment of stroke at different load (in) or (mm)

IMA-S - Hygienic Integrated Servo Actuator

RE-LUBRICATION RECOMMENDATION:

IMA-ST33, IMA-SA33: Lubrication requirements for IMA-S electric actuators depend on the motion cycle (velocity, force, duty cycle), type of application, ambient temperature, environmental surrounding and various other factors.

For many general purpose applications, Tolomatic ball screw actuators are typically considered lubricated for life unless otherwise specified, such as those actuator models outfitted with a re-lubrication feature. For roller screw or ball screw actuators outfitted with a re-lubrication feature, Tolomatic recommends to re-lubricate the actuator at least once per year or every 1,000,000 cycles, whichever comes first, to maximize service life. For more demanding applications such as pressing, high frequency or other highly stressed applications, the re-lubrication interval for these actuators will vary and will need to be more frequent. In these

demanding applications, it is recommended to execute at least 5 full stroke moves every 5,000 cycles of operation (or more frequent if possible) to re-distribute the grease within the actuator.

Re-lubricate with standard Tolomatic Grease #2744-9099 or optional Food grade grease #2733-1303 into the grease zerk located on the rod end.

	Quantity	
IMA-ST33	2.5 + [0.010 x L (mm)]	g
IMA-SA33	4.8 + [0.010 x L (mm)]	g
IMA-ST33	0.09 + [0.009 x L (in)]	oz
IMA-SA33	0.17 + [0.009 x L (in)]	oz
L=stroke length (mm or in)		

NOTE: IMA22ST does not accommodate relubrication

 In some applications oil may leak from the grease zerk. In contamination sensitive applications replace grease zerk with plug.

SIDE LOAD CONSIDERATIONS

The IMA-S integrated motor actuator is not meant to be used in applications where side loading occurs. Loads must be guided and supported. Loads should be aligned with the line of motion of the thrust rod. Side loading will affect the life of the actuator.



IMA-S SIDE LOAD SPECIFICATIONS

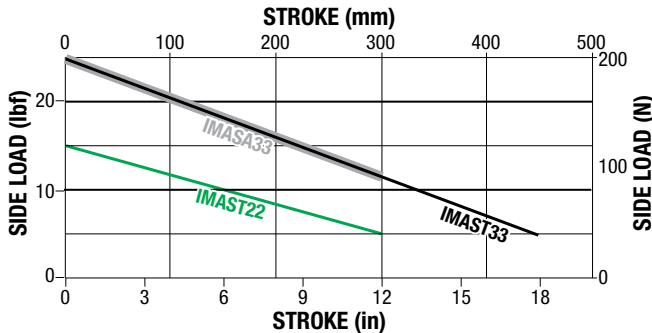

BRAKE CONSIDERATIONS

In all vertical application an unpowered IMA will require a brake to maintain position. Tolomatic recommends that the nominal back drive force specification (listed in the table on IMAS_6) be used for reference only. Back drive force is subject to change throughout the life of the actuator, due to mechanical break in, ambient temperature, and duty cycle variation.

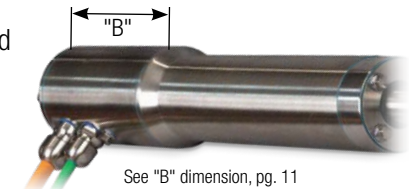

A brake can be used with the actuator to keep it from backdriving, typically in vertical applications. A brake may be used for safety reasons or for energy savings allowing the actuator to hold position when un-powered. See page IMAS_15 for ordering information.

NOTE: The optional Spring-Applied / Electronically-Released Brake requires 24V power. Input current rating: IMA-ST22 - 0.35 Amps; IMA-S_33 - 0.43 Amps;

Brake Specifications:

	SERIES	IMA-ST22	IMA-ST33	IMA-SA33
ROTOR INERTIA	gm-cm ²	19	73	73
	oz-in ²	0.104	0.400	0.400
CURRENT	Amp	0.35	0.43	0.43
HOLDING TORQUE	N-m	1.6	4.0	4.0
	in-lb	14	35	35
ENGAGE TIME	mSec	75	40	40
DISENGAGE TIME	mSec	20	50	50
VOLTAGE	Vdc	24		

IMA-S - Hygienic Integrated Servo Actuator

tolomatic.com/CAD Download 3D CAD Always use CAD solid model to determine critical dimensions



Dimensions: **All Sizes**

DIMENSIONS

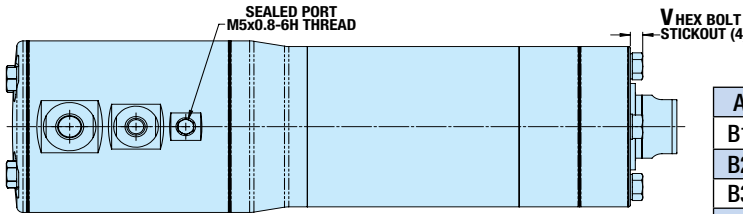
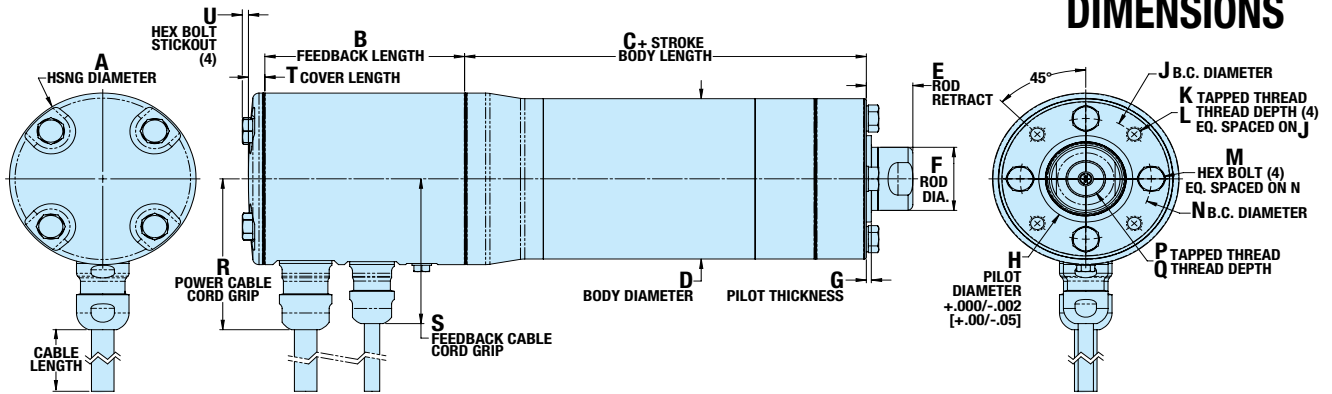

	ST22	ST33	SA33
A	76.2	95.3	95.3
B1	87.7	80.0	80.0
B2	119.1	121.4	121.4
B3	113.9	102.0	102.0
B4	142.7	140.1	140.1
C1**	123.7	158.8	381.6
C2**	126.2	161.4	384.1
D	64.0	89.0	89.0
E1	18.4	23.7	23.7
E2	15.9	21.2	21.2
F	25.38	35.00	35.00
G*	2.54	2.54	2.54
H*	35.500	48.000	48.000
J*	48.00	70.00	70.00
K*	M6x 1.0-6H	M8x 1.25-6H	M8x 1.25-6H
L*	12.5	13.0	13.0
M	M5	M8	M8
N	48.00	67.00	67.00
P	M12x 1.25-6H	M20x 1.5-6H	M20x 1.5-6H
Q	16.0	25.4	25.4
R †	73.6	83.8	83.8
S †	70.4	80.4	80.4
T	8.1	8.4	8.4
U1	1.7	3.1	3.1
U2	5.5	9.1	9.1
V1	4.5	6.3	6.3
V2	8.3	12.0	12.0

KEY FEATURES: 1-STACK & 3-STACK MOTORS

ST22		
SERIES	MV21/41	MV23/43
STROKE	mm	76.2 to 304.8
	in	3.0 to 12.0
PEAK FORCE	N	up to 1,446
	lbf	up to 325

ST33		
SERIES	MV21/41	MV23/43
STROKE	mm	76.2 to 457.2
	in	3.0 to 18.0
PEAK FORCE	N	up to 4,673
	lbf	up to 1,050

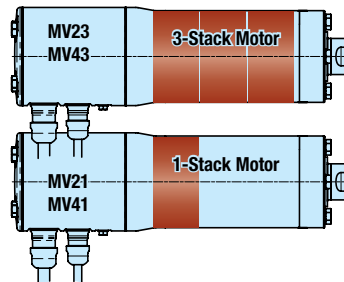

NOTE: See page IMAS_7 for IMA-SA33 stroke

Allows 3" to <6" Stroke

* Not compatible with PCD option

** C1 for standard actuator; C2 for actuator with PCD option

† Only 1 cord grip required with Sick Hiperface DSL

(no "S", separate feedback cable); 22 size (74.9 mm [2.99"]); 33 size (85.4 mm [3.36"])

	Units	ST22	ST33	SA33
A	in	3.00	3.75	3.75
B1	in	3.45	3.15	3.15
B2	in	4.69	4.78	4.78
B3	in	4.49	4.01	4.01
B4	in	5.62	5.51	5.51
C1**	in	4.87	6.25	15.02
C2**	in	4.97	6.35	15.12
D	in	2.52	3.50	3.50
E1	in	0.72	0.93	0.93
E2	in	0.62	0.83	0.83
F	in	0.999	1.378	1.378
G*	in	0.100	0.100	0.100
H*	in	1.3976	1.8898	1.8898
J*	in	1.890	2.756	2.756
K*	mm	M6x 1.0-6H	M8x 1.25-6H	M8x 1.25-6H
L*	in	0.49	0.51	0.51
M	mm	M5	M8	M8
N	in	1.890	2.638	2.638
P	mm	M12x 1.25-6H	M20x 1.5-6H	M20x 1.5-6H
Q	in	0.63	1.00	1.00
R †	in	2.90	3.30	3.30
S †	in	2.77	3.16	3.16
T	in	0.32	0.33	0.33
U1	in	0.07	0.12	0.12
U2	in	0.22	0.36	0.36
V1	in	0.18	0.25	0.25
V2	in	0.33	0.47	0.47

Dimensions in inches (threads are metric)

Dimensions in millimeters

Item	Code	Description
B1	CA2 A2N	Allen Bradley VP Connector, SICK Hiperface DSL
	CT2 A2N	Tolomatic Standard VP Connector, SICK Hiperface DSL
	FA2 A2N	Allen Bradley Flying Lead, SICK Hiperface DSL
	FT2 A2N	Tolomatic Standard Flying Lead, SICK Hiperface DSL
B2	CA2 A2B	Allen Bradley VP Connector, SICK Hiperface DSL, Brake
	CT2 A2B	Tolomatic Standard VP Connector, SICK Hiperface DSL, Brake
	FA2 A2B	Allen Bradley Flying Lead, SICK Hiperface DSL, Brake
	FT2 A2B	Tolomatic Standard Flying Lead, SICK Hiperface DSL, Brake
B3	FA1 A1N	Allen Bradley Flying Lead, SICK Hiperface
	FT1 A1N	Tolomatic Standard Flying Lead, SICK Hiperface
	FT1 D1N	Tolomatic Standard Flying Lead, Incremental
	FT1 H1N	Tolomatic Standard Flying Lead, Heidenhain Endat 2.2
	FT1 R1N	Tolomatic Standard Flying Lead, Resolver

Item	Code	Description
B4	FA1 A1B	Allen Bradley Flying Lead, SICK HIPERFACE, Brake
	FT1 A1B	Tolomatic Standard Flying Lead, SICK HIPERFACE, Brake
	FT1 D1B	Tolomatic Standard Flying Lead, Incremental, Brake
	FT1 H1B	Tolomatic Standard Flying Lead, Heidenhain Endat 2.2, Brake
	FT1 R1B	Tolomatic Standard Flying Lead, Resolver, Brake
C1	—	Standard
C2	PCD	With PCD Option
E1	—	Standard
E2	PCD	With PCD Option
U1	—	Standard
U2	HYG2	With HYG2 Option
V1	—	Standard
V2	HYG2	With HYG2 Option

IMA-S - Hygienic Integrated Servo Actuator

tolomatic.com/CAD Download 3D CAD Always use CAD solid model to determine critical dimensions



Dimensions: Rod End Options

EXTERNAL THREADED ROD END (MET)

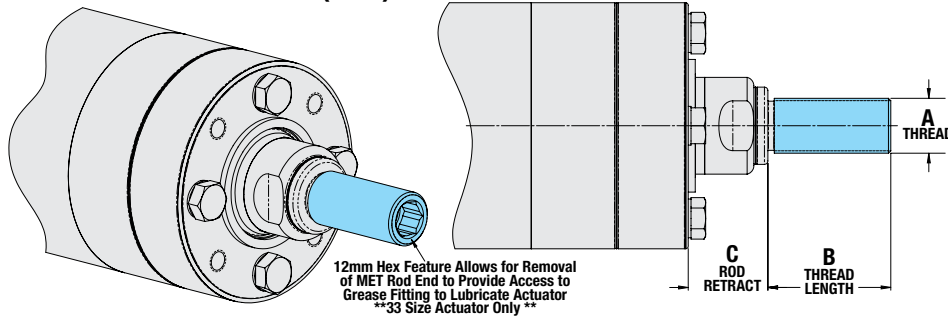

	ST22	ST33	SA33
A	M16x 1.5-6g	M20x 1.5-6g	M20x 1.5-6g
B	37.3	44.5	44.5
C	18.4	28.8	28.8

Dimensions in millimeters

	UNITS	ST22	ST33	SA33
A	mm	M16x 1.5-6g	M20x 1.5-6g	M20x 1.5-6g
B	in	1.47	1.75	1.75
C	in	0.72	1.13	1.13

Dimensions in inches (threads are metric)

Dimensions: Mounting Options

FRONT FLANGE MOUNT (FFG)

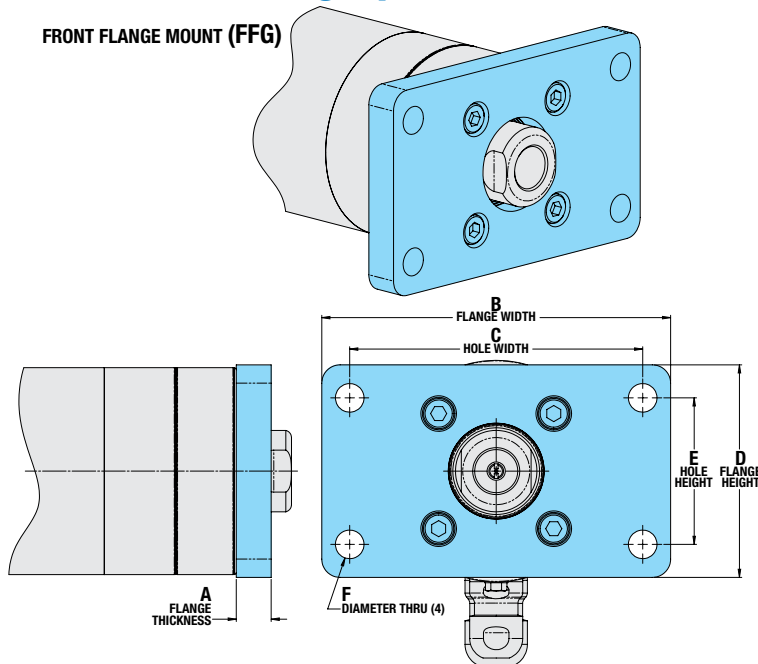

	ST22	ST33	SA33
A	11.2	15.0	15.0
B	117.3	150.0	150.0
C	100.0	126.0	126.0
D	67.3	91.4	91.4
E	50.0	63.0	63.0
F	8.7	12.3	12.3

Dimensions in millimeters

	ST22	ST33	SA33
A	0.44	0.59	0.59
B	4.62	5.91	5.91
C	3.94	4.96	4.96
D	2.65	3.60	3.60
E	1.97	2.48	2.48
F	0.34	0.48	0.48

Dimensions in inches

REAR CLEVIS MOUNT (PCD)

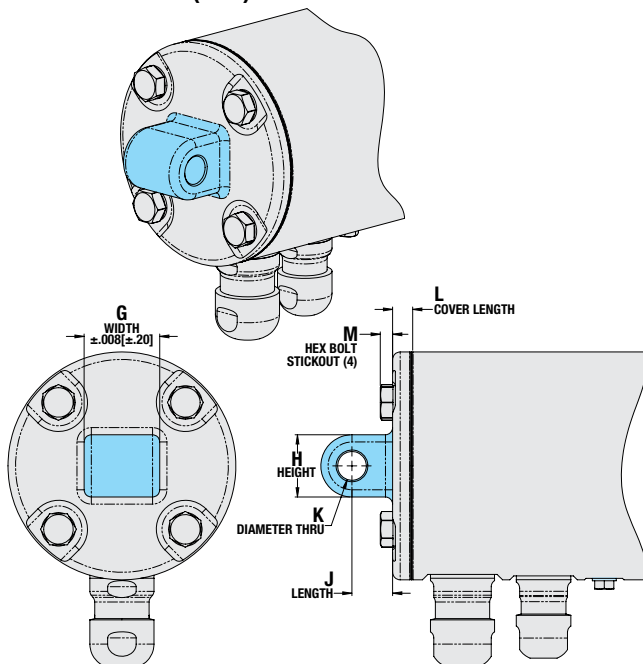

	ST22	ST33	SA33
G	25.6	31.6	31.6
H	22.0	26.0	26.0
J	14.1	17.1	17.1
K	10.036/ 10.000	12.043/ 12.000	12.043/ 12.000
L	8.1	8.4	8.4
M1*	3.6	5.2	5.2
M2*	7.4	10.9	10.9

Dimensions in millimeters

	ST22	ST33	SA33
G	1.01	1.24	1.24
H	0.87	1.02	1.02
J	0.56	0.67	0.67
K	0.3951/ 0.3937	0.4741/ 0.4724	0.4741/ 0.4724
L	0.32	0.33	0.33
M1*	0.14	0.20	0.20
M2*	0.29	0.43	0.43

Dimensions in inches

*M1 Standard actuator; M2 with HYG2 option

IMA-S - Hygienic Integrated Servo Actuator

Selection Guidelines

1 ESTABLISH MOTION PROFILE

Using the application stroke length, desired cycle time and loads establish the motion profile details.

2 COMPARE OPERATING (PEAK) FORCE AND VELOCITY TO OPERATING REGION

Calculate the application required operating (peak) force and velocity and compare to tables on pages IMAS_6. The calculated force and velocity must fall within the operating region of the actuator.

3 COMPARE SEVERE DUTY (CONTINUOUS) FORCE AND VELOCITY TO SEVERE DUTY REGION

Calculate the RMS force and velocity required and compare to tables on pages IMAS_6-7. The calculated force and velocity must fall within the severe duty region.

$$T_{RMS} = \sqrt{\frac{\sum (T_i^2 \times t_i)}{\sum (t_i)}} \quad v_{RMS} = \sqrt{\frac{\sum (V_i^2 \times t_i)}{\sum (t_i)}}$$

4 CONSIDER SCREW/NUT CHOICES

Choose roller nuts for its longer life (see Life graph on page IMAS_9) and higher peak loads (see graphs on pages IMAS_8). Ball nuts are cost competitive and more efficient (see table on page IMAS_6).

SCREW ACCURACY

Roller Nut	± 0.0004"/ft.	± 0.0102mm/300mm
Ball Nut	± 0.002"/ft.	± 0.051mm/300mm

5 VERIFY CRITICAL SPEED OF THE SCREW

Verify that the application's peak linear velocity does not exceed the critical speed value for the size and lead of the screw selected.

6 VERIFY AXIAL BUCKLING STRENGTH OF THE SCREW

Verify that the peak force does not exceed the critical buckling force for the size of the screw selected.

7 MOTOR WINDINGS & VOLTAGES

Choose motor windings optimized for 230 Vac and 460 Vac voltage busses. The 1 stack motor (MV21-230V & MV41-460V), available for the IMA-S22/33, allows strokes of 3" (76.2mm) vs the minimum 6" (152.4mm) stroke required for 3 stack motors, providing the force needed for many applications in a more compact, lighter weight package

8 CALCULATE LUBRICATION INTERVAL

See page IMAS_10 for an overview and IMA-S Users Guide (#2700-4016) for complete instructions to calculate lubrication interval.

9 TEMPERATURE

The IMA-S is intended to operate in an environment with an ambient temperature between -4 to +104°F, (-10 to +40°C). Performance should be de-rated if the ambient temperature is above 77°F (25°C). Contact the factory if the ambient temperature does not fit within this range. NOTE: Temperature

of the actuator's body can approach 180°F (82°C) in aggressive applications. Adequate clearance to ensure actuator's ambient conditions do not rise drastically should be allowed.

10 BRAKE CONSIDERATIONS

In all vertical application an unpowered IMA will require a brake to maintain position. Tolomatic recommends that the nominal back drive force specification (listed in the table on page IMAS_6) be used for reference only. Back drive force is subject to change throughout the life of the actuator, due to mechanical break in, ambient temperature, and duty cycle variation.

A brake can be used with the actuator to keep it from back-driving, typically in vertical applications. A brake may be used for safety reasons or for energy savings allowing the actuator to hold position when un-powered. See page IMAS_15 for ordering information.

NOTE: The optional Spring-Applied/Electronically Released Brake requires 24V power. Input current rating: IMA22 - 0.35Amps; IMA33 - 0.43Amps;

11 CHOOSE MOTOR CONNECTORS & FEEDBACK DEVICE

Connector choice and wiring emulates popular motor manufacturers for compatibility. Cable/connector options include:

- Allen Bradley VP series
- Tolomatic standard
- Flying leads
- Cables are available in 3m, 5m and 10m lengths

Feedback options include:

- Incremental Encoder
- Absolute Encoder, Hiperface, Hiperface DSL, EnDat 2.2
- Resolver

Contact Tolomatic for additional motor connectors, feedback combinations and motor files for third party drives.

12 CONSIDER MOUNTING & ROD END OPTIONS

Examine mounting options dimensional drawings on page IMAS_12. Standard mounting on the IMA-S are 4 tapped holes on the front rod end face of the actuator. Other fixed mounting option is the Front Flange Mount (FFG). Pivoting mount option is the Rear Clevis Mount (PCD).

Rod End Option is: External Threaded Rod End (MET).

NOTE: Regardless of the mounting option chosen, care must be taken to ensure that the load is guided and in-line with the force rod's line of motion. Misalignment of the force rod's line of motion will cause degradation in the actuator's expected life.

13 CONSIDER ENVIRONMENTAL RATING AND ANTI-ROTATE OPTIONS

The environmental rating for a standard IMA-S is IP69K for protection against water and dust ingress. Choose the Anti-Rotate Option (IMA-SA) if required. Call Tolomatic at 1-800-328-2174 for help in determining the best actuator for your application.



APPLICATION DATA WORKSHEET Fill in known data. Not all information is required for all applications

ORIENTATION

Horizontal

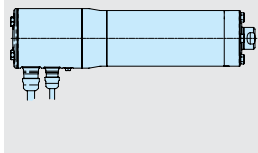

Vertical

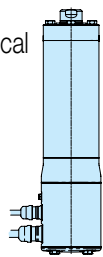

Incline °

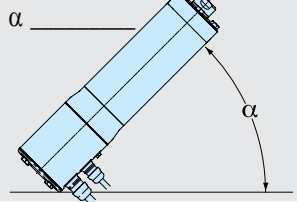

Load supported by actuator OR Load supported by other mechanism



MOVE PROFILE

EXTEND

Move Distance _____

inch millimeters

Move Time _____ sec

Max. Speed _____

in/sec mm/sec

Dwell Time After Move _____ sec

RETRACT

Move Distance _____

inch millimeters

Move Time _____ sec

Max. Speed _____

in/sec mm/sec

Dwell Time After Move _____ sec

NO. OF CYCLES

per minute per hour

HOLD POSITION? Required

Not Required

After Move During Power Loss

STROKE LENGTH

order in _____ millimeters (S M)
mm ONLY (Metric)

NOTE: If load or force changes during cycle use the highest numbers for calculations

EXTEND

LOAD

lb kg
(U.S. Standard) (Metric)

FORCE

lbf N
(U.S. Standard) (Metric)

RETRACT

LOAD

lb kg
(U.S. Standard) (Metric)

FORCE

lbf N
(U.S. Standard) (Metric)

PRECISION

Repeatability _____

inch millimeters

OPERATING ENVIRONMENT

Temperature, Contamination, Water, etc.

MOTION PROFILE

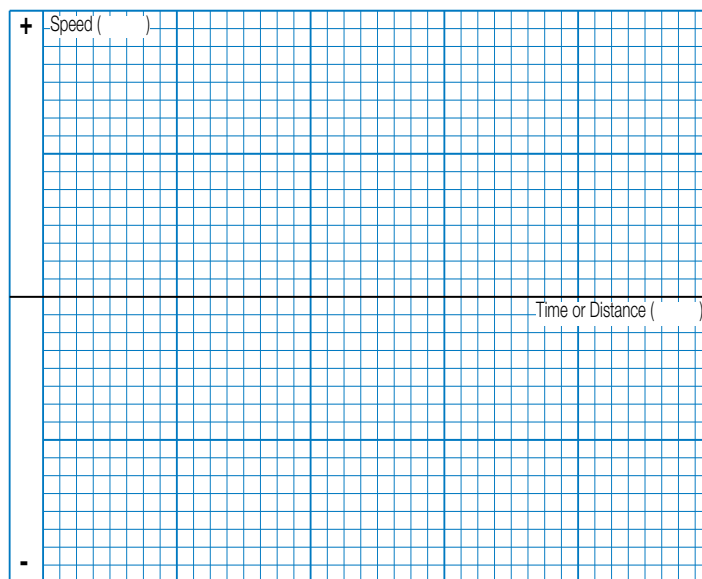

Graph your most demanding cycle, including accel/decel, velocity and dwell times. You may also want to indicate load variations and I/O changes during the cycle. Label axes with proper scale and units.

CONTACT INFORMATION

Name, Phone, Email
Co. Name, Etc.



USE THE TOLOMATIC SIZING AND SELECTION SOFTWARE AVAILABLE ON-LINE AT www.tolomatic.com OR... CALL TOLOMATIC AT 1-800-328-2174. We will provide any assistance needed to determine the proper actuator for the job.

FAX 1-763-478-8080

EMAIL help@tolomatic.com

IMA-S - Hygienic Integrated Servo Actuator

Ordering

MODEL SELECTION (MUST BE IN THIS ORDER)

I M A S T 3 3 R N 0 5 S M 3 0 4 . 8 M V 2 3 C T 2 A 2 N C R 5 F F G H Y G 2 H Y G 3

OPTIONS (IN ANY ORDER)

MODEL	
IMA-ST	Stainless IMA Standard
IMA-SA	Stainless IMA Anti-Rotate

SIZE	
22	22 Series Actuator (Anti-Rotate not available)
33	33 Series Actuator

NUT / SCREW			
Screw/Nut combinations available			
22	33	33SA	Description
BN05	BN05	—	Ball Nut, 5 mm lead
BN10	BN10	—	Ball Nut, 10 mm lead
—	BN20	—	Ball Nut, 20 mm lead
—	RN04	RN04	Roller Nut, 4 mm lead
—	RN05	RN05	Roller Nut, 5 mm lead
—	RN10	RN10	Roller Nut, 10 mm lead

STROKE LENGTH	
SM _ _ . _	Stroke, enter stroke length in millimeters
<i>NOTE: See page IMAS_7 for stroke min. & max.</i>	

MOTOR VOLTAGE	
MV21*	230 Vac, Motor Voltage, 1 Stack Winding
MV41*	460 Vac, Motor Voltage, 1 Stack Winding
MV23	230 Vac, Motor Voltage, 3 Stack Winding
MV43	460 Vac, Motor Voltage, 3 Stack Winding
 <i>*NOTE: Not available for "SA" Anti-Rotate actuators</i>	

BRAKE OPTION	
N	NO Brake
B	Brake

CABLE(S)	
CR3	3m cable(s), power and feedback
CR5	5m cable(s), power and feedback
CR10	10m cable(s), power and feedback
For custom cable lengths please contact Tolomatic. Lead times will vary.	

ROD END OPTIONS	
—	Standard , female, internally threaded rod end
MET	Male Externally Threaded Rod End

MOUNTING OPTIONS	
—	Standard Face Mount
FFG	Front Flange Mount
PCD	Clevis Mount, Rear
PCDR	Clevis Mount, Rear (Rotated 90°)

OTHER OPTIONS*	
HYG2	Hygienic Fasteners
HYG3	FDA Rod Wipers
*Order none, 1 or both	

 Contact Tolomatic for Lead Time
Some feedback devices are not compatible with some connectors.
Contact Tolomatic for complete motor connector & feedback combination information

MOTOR SERIES CONNECTORS	FEEDBACK DEVICE
Cable + Allen Bradley VP Connector	CA2 A2 SICK Hiperface DSL
Allen Bradley Flying Lead	FA1 A1 SICK Hiperface
Allen Bradley Flying Lead	FA2 A2 SICK Hiperface DSL
Cable + Tolomatic Std. VP Connector	CT2 A2 SICK Hiperface DSL
Tolomatic Std. Flying Lead	FT1 D1 Incremental

MOTOR SERIES CONNECTORS	FEEDBACK DEVICE
Tolomatic Std. Flying Lead	FT1 A1 SICK Hiperface
Tolomatic Std. Flying Lead	FT1 H1 Heidenhain Endat 2.2
Tolomatic Std. Flying Lead	FT1 R1 Resolver
Tolomatic Std. Flying Lead	FT2 A2 SICK Hiperface DSL

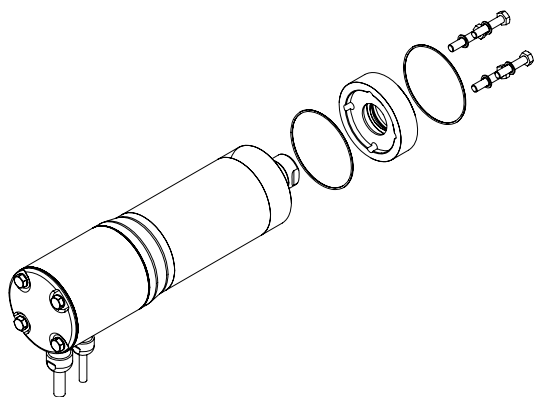

REPLACEABLE SEAL CARTRIDGE			
Description	IMA-ST22	IMA-ST33	IMA-SA33
Standard	2622-9070	2633-9070	2633-9070
Standard with Rear Clevis Mount (PCD_)	2622-9071	2633-9071	2633-9071
FDA Rod Wipers (HYG3)	2622-9072	2633-9072	2633-9072
FDA Rod Wipers (HYG3 with Rear Clevis Mount (PCD_))	2622-9073	2633-9073	2633-9073



The Tolomatic Difference Expect More From the Industry Leader:



INNOVATIVE PRODUCTS

Solutions with Endurance TechnologySM for challenging applications.



FAST DELIVERY

Built-to-order with configurable stroke lengths and flexible mounting options.



ACTUATOR SIZING

Size and select electric actuators with our online software.



YOUR MOTOR HERE[®]

Match your motor to compatible mounting plates with Tolomatic actuators.



CAD LIBRARY

Download 2D or 3D CAD files for Tolomatic products.



TECHNICAL SUPPORT

Get a question answered or request a virtual design consultation with one of our engineers.

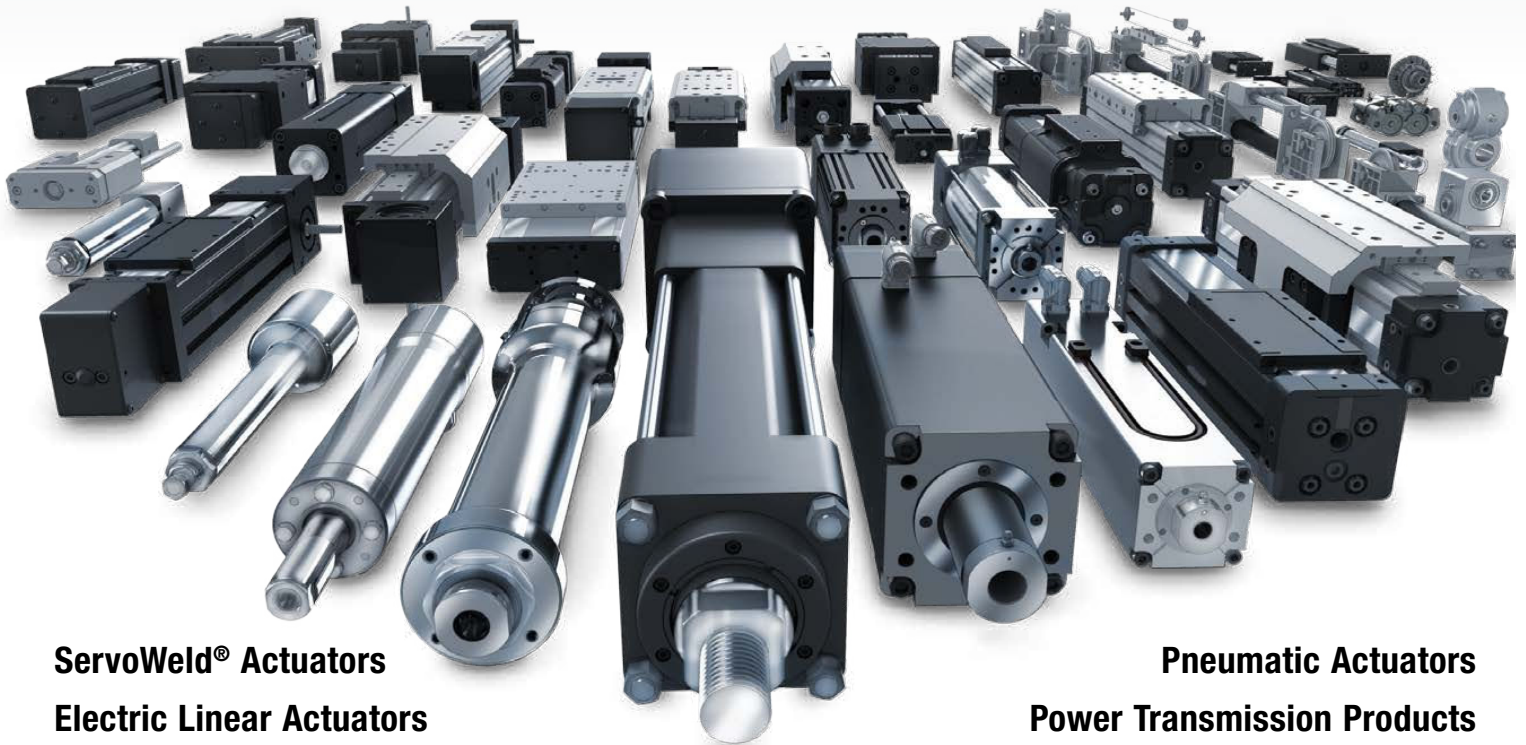

ServoWeld[®] Actuators
Electric Linear Actuators

Pneumatic Actuators
Power Transmission Products



MADE IN U.S.A.

Tolomatic[™]

EXCELLENCE *IN* MOTION

COMPANY WITH
QUALITY SYSTEM
CERTIFIED BY DNV
= ISO 9001 =
Certified site: Hamel, MN

USA - Headquarters

Tolomatic Inc.

3800 County Road 116
Hamel, MN 55340, USA

Phone: (763) 478-8000

Toll-Free: **1-800-328-2174**

sales@tolomatic.com

www.tolomatic.com

MEXICO

Centro de Servicio

Parque Tecnológico Innovación
Int. 23, Lateral Estatal 431,
Santiago de Querétaro,

El Marqués, México, C.P. 76246

Phone: +1 (763) 478-8000

help@tolomatic.com

EUROPE

Tolomatic Europe GmbH

Elisabethenstr. 20
65428 Rüsselsheim
Germany

Phone: +49 6142 17604-0

help@tolomatic.eu

www.tolomatic.com/de-de

CHINA

Tolomatic Automation Products (Suzhou) Co. Ltd.

No. 60 Chuangye Street, Building 2
Huqiu District, SND Suzhou
Jiangsu 215011 - P.R. China

Phone: +86 (512) 6750-8506

Tolomatic_China@tolomatic.com

All brand and product names are trademarks or registered trademarks of their respective owners. Information in this document is believed accurate at time of printing. However, Tolomatic assumes no responsibility for its use or for any errors

that may appear in this document. Tolomatic reserves the right to change the design or operation of the equipment described herein and any associated motion products without notice. Information in this document is subject to change without notice.

Visit www.tolomatic.com for the most up-to-date technical information