

# ServoWeld<sup>TM</sup> Actuators

## GSWA MODELS



**FOR RESISTANCE SPOT WELDING**

# ServoWeld GSWA

Tolomatic is the world's leading manufacturer of integrated servo actuators for resistance spot welding used by the world's top weld gun OEM's and numerous global vehicle manufacturers.



## Superior Integrated Servo Motor Actuators

Tolomatic's ServoWeld family of integrated servo actuators are designed for best-in-class performance with the factors that are most important for resistance spot welding gun applications.

### NUMBER OF WELDS/ PRODUCT LIFE

Tolomatic's superior roller screw design has the **highest dynamic load rating for more welds** than any competitive technology (other roller screws, ball screw, pneumatic).

### FORCE REPEATABILITY

Skewed winding designed for welding minimizes motor cogging and **provides industry best actuator force repeatability:** •  $\pm 3\%$  Over the Lifetime of the Actuator

### EFFICIENCY

All elements of actuator (winding, screw, rod scraper, bearings) are designed to optimize the efficiency of the actuator system and provide the **most energy efficient solution on the market.**

### WELDS/ MINUTE

All elements of the actuator (winding, screw, rod scraper, bearings) are designed to last and run as cool as possible in welding applications, with the ability to add water cooling as an option. This means **more welds per minute than any competitive technology** (other roller screws, ball screw, pneumatic).

### WEIGHT

Tolomatic integrated servo actuators minimize weight when designed into the weldgun. Additionally, Tolomatic can customize actuators for a specific weldgun applications to provide **industry leading light weight designs.**

### LIFETIME COST

By building the longest lasting, most efficient and highest weld per minute actuators on the market, Tolomatic actuators provide the **lowest total cost per spot weld.**

## ServoWeld Applications

### Additional Welding Applications:

- Pedestal Welding
- Projection Welding

PINCH STYLE

"X" STYLE

"C" STYLE

# Typical Robotic ServoWeld Installation

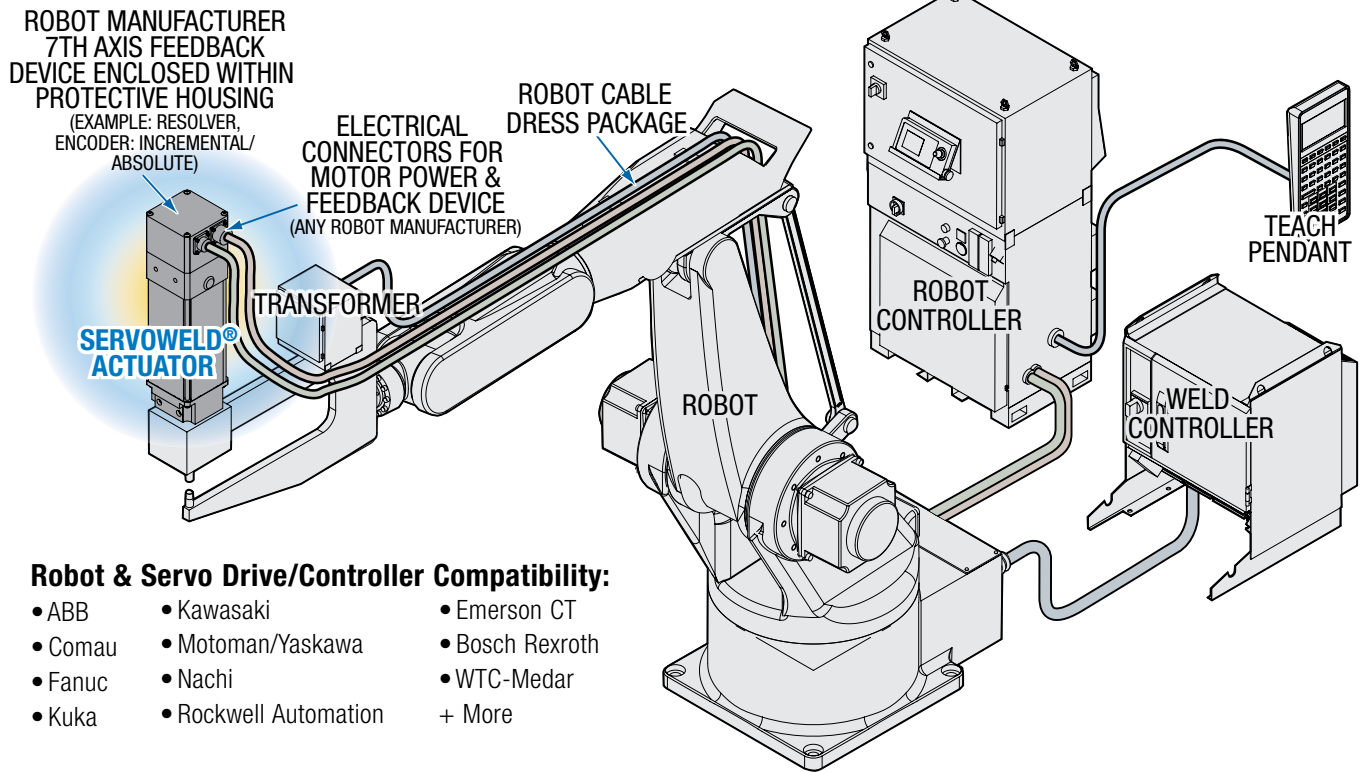

## Tolomatic Offers the Broadest, Most Capable Family of Integrated Servo Actuators for Resistance Spot Welding

| Model:  | GSWA   | SWA/SWB  | CSWX  |
|---|--|--|---|
| <b>Number of Welds<sup>1</sup> (millions):</b>  | 20+  | 20+ (10+ SWB)                                      | 30+ (20+ CSW)                                       |
| <b>Re-lubrication without Disassembly:</b>  | Yes <sup>4</sup>   | Yes  | Yes   |
| <b>Peak Force:</b>  | 36.7 kN [8,243 lbf]  | 24.0 kN [5,395 lbf] SWA<br>22.0 kN [4,950 lbf] SWB | 18.0 kN [4,047 lbf] CSWX<br>15.6 kN [3,500 lbf] CSW |
| <b>Actuator Output Force<sup>2</sup> (Lifetime) Repeatability:</b>                    | ±3%  | ±3% (±5% SWB)                                      | ±3%   |
| <b>Weight (size 33,3)<sup>3</sup> (size 44,04)<sup>3</sup> (size 55)<sup>3</sup>:</b> | 8.3 kg [18.3 lb]<br>13.8 kg [30.4 lb]<br>30.5 kg [67.2 lb] | 7.2 kg [15.9 lb]<br>14.2 kg [31.2 lb]              | min: 10.2 kg [22.6 lb]                              |
| <b>Water Cooling:</b>   | Optional   | Optional   | Optional  |
| <b>Manual Override:</b>   | Optional   | No   | Optional  |
| <b>Full Force Direction:</b>  | Push and Pull  | Push   | Push and Pull                                       |

<sup>1</sup> Based on properly lubricated ServoWeld unit used as recommended in user manual. Weld schedule, tip force, environment and lubrication are factors in the total number of welds achievable with ServoWeld actuators.

<sup>2</sup> At weld force

<sup>3</sup> Weight varies with choice of feedback device and mounting options

<sup>4</sup> Some exceptions, see GSWA user manual

# GSWA33 INTEGRATED MOTOR ACTUATOR

## ENDURANCE TECHNOLOGY<sup>SM</sup>

A Tolomatic Design Principle

Endurance Technology features are designed for maximum durability to provide extended service life.

### ADVANCED SCREW TECHNOLOGY

- Roller screws provide the highest thrust and life ratings available



### INTERNAL BUMPERS

Bumpers protect the screw and nut assembly from damage at end of stroke

### SKEWED MOTOR WINDINGS

Skewed motor windings provide minimal torque ripple for force repeatability and smooth linear motion

### ROD WIPER WITH SCRAPER

Prevents contaminants from entering the actuator for extended life

### INTEGRAL MOUNTING

Four threaded holes on front face are available for direct mounting or addition of customized options<sup>9</sup>

### GREASE PORT

- Patented screw re-lubrication system provides extended screw life
- Convenient lubrication without disassembly

### THREADED ROD END

- Zinc plated steel construction for corrosion resistance
- Provides a common interface to multiple rod end options

### THRUST TUBE

- Steel thrust tube supports extremely high force capabilities
- Salt bath nitride treatment provides excellent corrosion resistance, surface hardness and is very resistant to adherence of weld slag, water and other potential contaminants

### LIGHTWEIGHT ALUMINUM DESIGN

Black anodized extrusion design is optimized for rigidity and strength

# Tolomatic™... MAXIMUM DURABILITY

EXCELLENCE IN MOTION

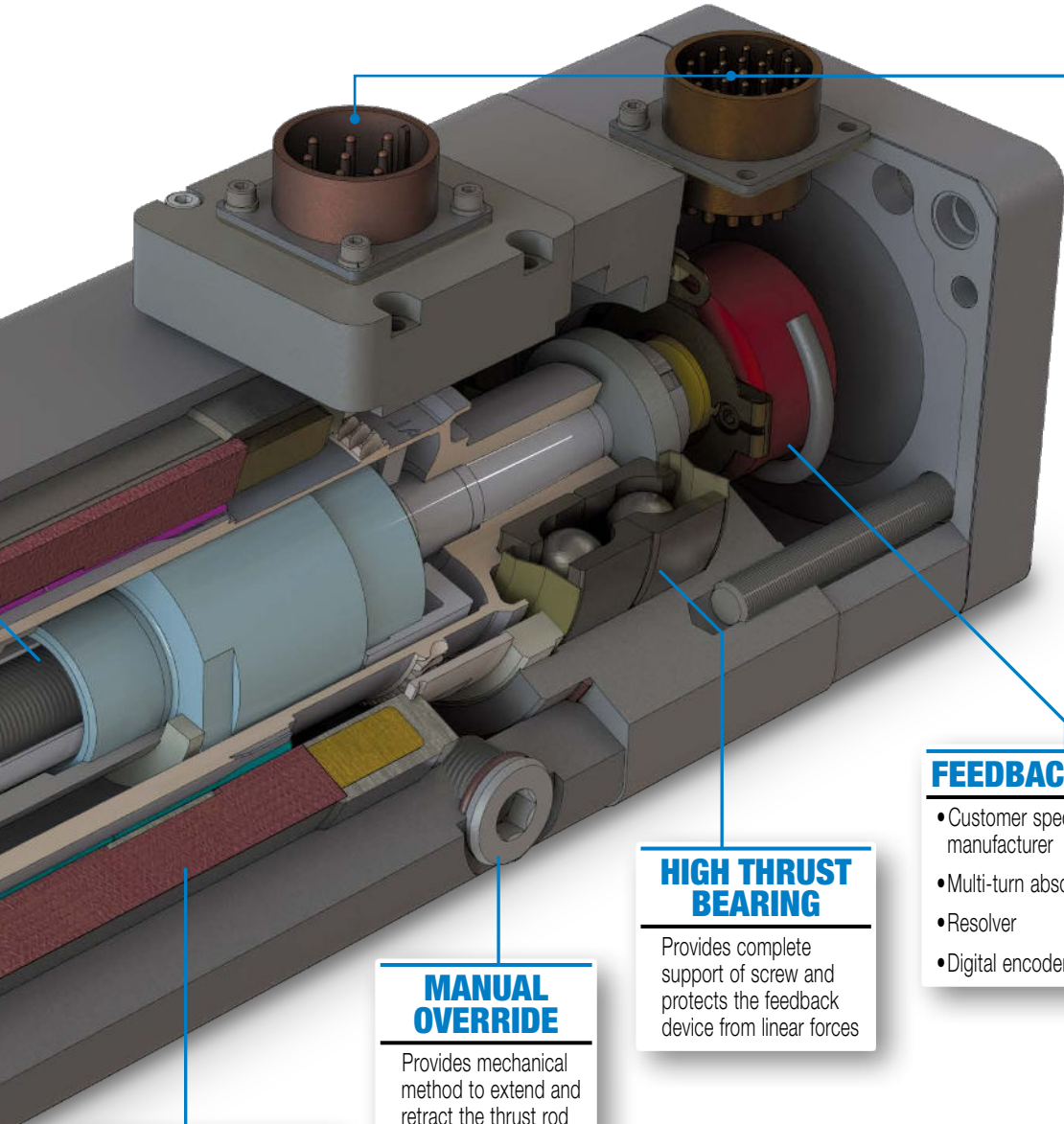

## ROBOT & DRIVE/ CONTROLLER COMPATIBILITY

Compatible feedback, connector(s) and wiring to match the following robot & drive/controller manufacturers' cable dress packages

### YOUR CHOICE:

- + ABB
- + Comau
- + Fanuc
- + Kawasaki
- + Kuka
- + Motoman/Yaskawa
- + Nachi
- + Rockwell Automation
- + Bosch-Rexroth
- + Emerson CT
- + WTC-Medar
- & more

## FEEDBACK CHOICES

- Customer specified to robot manufacturer
- Multi-turn absolute encoder
- Resolver
- Digital encoder

## HIGH THRUST BEARING

Provides complete support of screw and protects the feedback device from linear forces

## MANUAL OVERRIDE

Provides mechanical method to extend and retract the thrust rod in power off situations

## MULTIPLE MOTOR WINDINGS

### YOU CAN CHOOSE:

- 460VAC or 230VAC rated windings potted directly into actuator housing
- Integral thermal switch for over temperature protection

## IP65

IP65 rating protects actuator from ingress of water, weld slag and other debris (static)

## OPTIONS

**BRAKE** • Spring held / 24V electrically released

**WATER COOLING**

**MANUAL OVERRIDE**

**LIGHT WEIGHT**

**REAR TRUNNION MOUNTING**

# GSWA33, GUIDED INTEGRATED MOTOR ACTUATOR

## ENDURANCE TECHNOLOGY<sup>SM</sup>

A Tolomatic Design Principle

*Endurance Technology features are designed for maximum durability to provide extended service life.*

### ROBUST BUSHINGS

- Large bushings provide additional side loading support for the thrust tube protecting the screw assembly
- Eliminates external guide on RSW chassis
- Protects guided mechanism in RSW environment

### ROD WIPER WITH SCRAPER

Prevents contaminants from entering the actuator for extended life

### THRUST TUBE

- Steel thrust tube supports extremely high force capabilities
- Salt bath nitride treatment provides excellent corrosion resistance, surface hardness and is very resistant to adherence of weld slag, water and other potential contaminants
- Large diameter guided thrust tube

### ANTI-ROTATE ASSEMBLY

- Fully enclosed to protect components from harsh environments
- Provides additional side loading support

### ANTI-ROTATE MECHANISM

- Far more efficient than sliding designs
- Robust needle bearing resists wear

### THREADED ROD END

- Zinc plated steel construction for corrosion resistance
- Provides a common interface to multiple rod end options

### INTEGRAL MOUNTING

- Four holes on anti-rotate assembly are available for direct mounting or addition of customized options
- 2 dowel pins are located a bottom of anti-rotate unit for accurate positioning

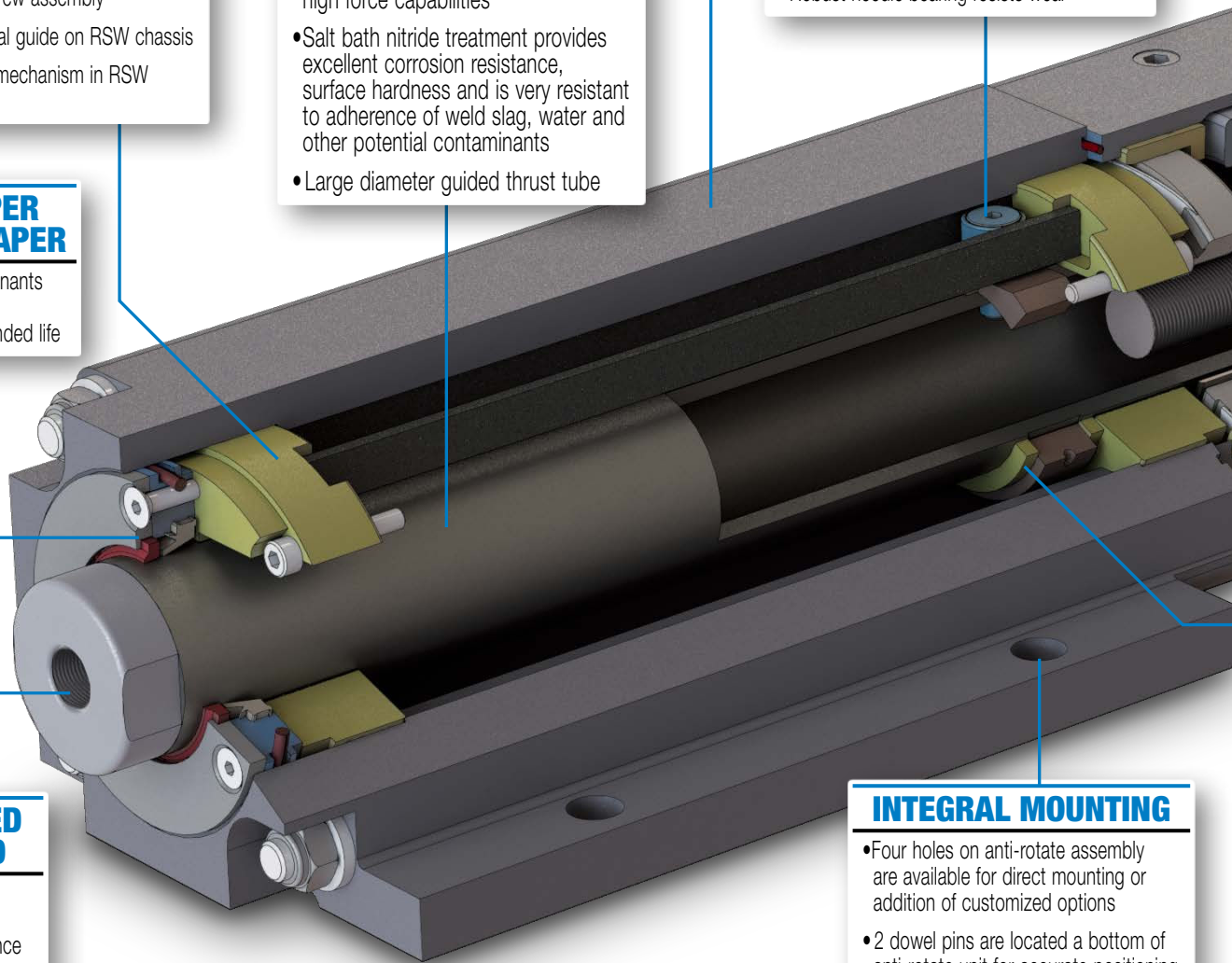

# Tolomatic™ ... MAXIMUM DURABILITY

EXCELLENCE IN MOTION

## MULTIPLE MOTOR WINDINGS

YOU CAN CHOOSE:

- 460VAC or 230VAC rated windings potted directly into actuator housing
- Integral thermal switch for over temperature protection

## ROBOT & DRIVE/CONTROLLER COMPATIBILITY

Compatible feedback, connector(s) and wiring to match the following robot & drive/controller manufacturers' cable dress packages

YOUR CHOICE:

- + ABB
- + Comau
- + Fanuc
- + Kawasaki
- + Kuka
- + Motoman/Yaskawa
- + Nachi
- + Rockwell Automation
- + Bosch-Rexroth
- + Emerson CT
- + WTC-Medar
- & more

## FEEDBACK CHOICES

- Customer specified to robot manufacturer
- Multi-turn absolute encoder
- Resolver
- Digital encoder

## HIGH THRUST BEARING

Provides complete support of screw and protects the feedback device from linear forces

## MANUAL OVERRIDE

Provides mechanical method to extend and retract the thrust rod in power off situations

## SKEWED MOTOR WINDINGS

Skewed motor windings provide minimal torque ripple for force repeatability and smooth linear motion

## INTERNAL BUMPERS

Bumpers protect the screw and nut assembly from damage at end of stroke

## ADVANCED SCREW TECHNOLOGY

- Roller screws provide the highest thrust and life ratings available



## IP65

IP65 rating protects actuator from ingress of water, weld slag and other debris (static)

## OPTIONS

- BRAKE** • Spring held / 24V electrically released
- WATER COOLING**
- REAR TRUNNION MOUNTING**

# GSWA 04 & 44 INTEGRATED MOTOR ACTUATOR

## ENDURANCE TECHNOLOGY<sup>SM</sup>

A Tolomatic Design Principle

Endurance Technology features are designed for maximum durability to provide extended service life.

Pictured below is the GSWA04. The GSWA44 has similar operating characteristics to the GSWA04, except the GSWA44 can be used on longer stroke applications and applications requiring weld force on retract. The GSWA44 does not have the manual override feature.

### MULTIPLE MOTOR WINDINGS

YOU CAN CHOOSE:

- 460VAC or 230VAC rated windings potted directly into actuator housing
- Integral thermal switch for over temperature protection

### LIGHTWEIGHT ALUMINUM DESIGN

Black anodized extrusion design is optimized for rigidity, strength and heat dissipation

### ROD WIPER WITH SCRAPER

Prevents contaminants from entering the actuator for extended life

### THRUST TUBE

- Steel thrust tube supports extremely high force capabilities
- Salt bath nitride treatment provides excellent corrosion resistance, surface hardness and is very resistant to adherence of weld slag, water and other potential contaminants

### THREADED ROD END

- Solid stainless steel construction for corrosion resistance
- Provides a common interface to multiple rod end options

### INTEGRAL MOUNTING

Threaded holes on front face are available for direct mounting or addition of customized options

### ROBUST BUSHINGS

Supports the thrust tube and nut assembly through entire stroke length

### INTERNAL BUMPERS

Bumpers protect the screw and nut assembly from damage at end of stroke

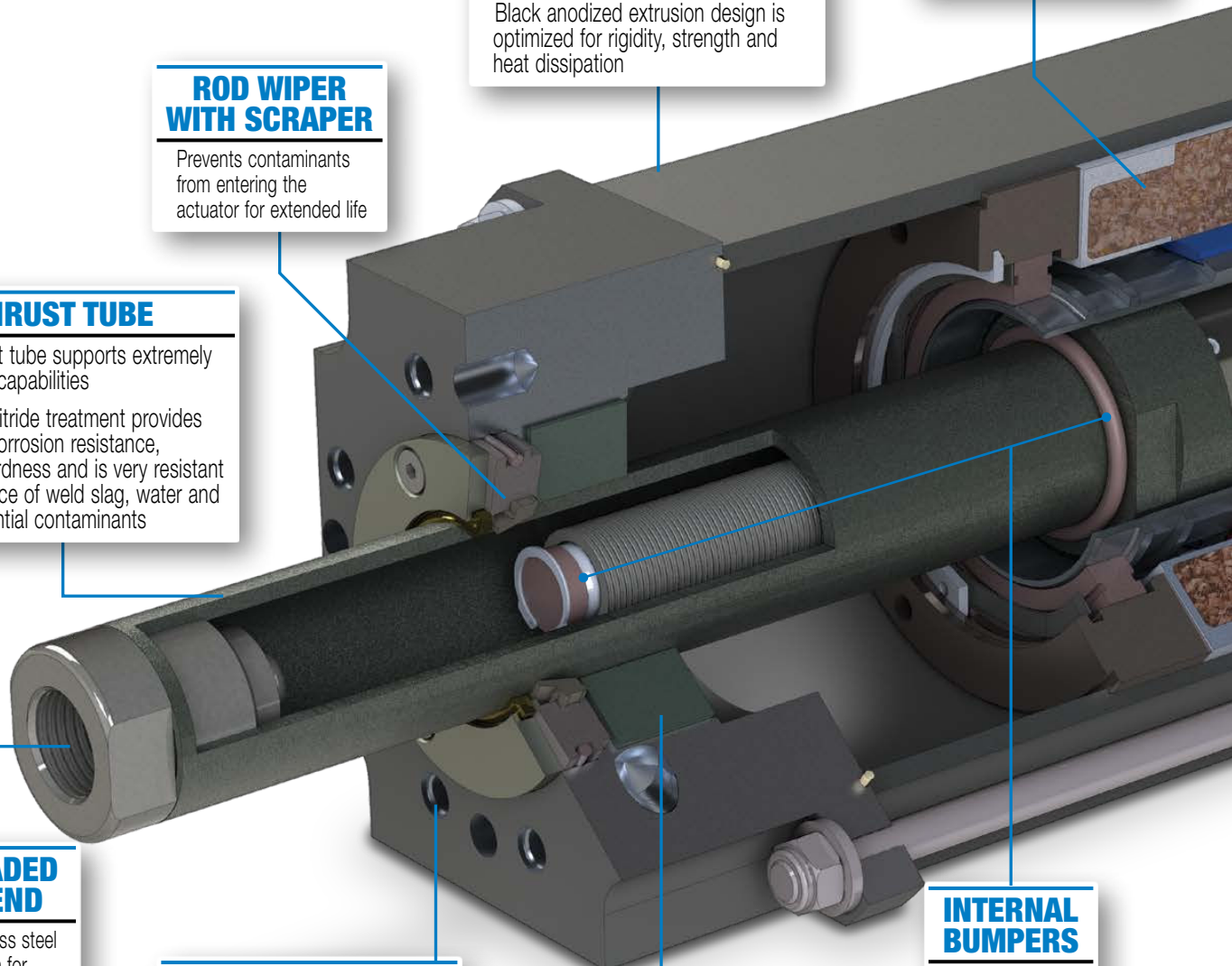

# Tolomatic... MAXIMUM DURABILITY

EXCELLENCE IN MOTION

## MANUAL OVERRIDE

Provides mechanical method to extend and retract the thrust rod in power off situations (Two access ports 180° apart) Available on GSWA04 only.

## ROBOT & DRIVE/CONTROLLER COMPATIBILITY

Compatible feedback, connector(s) and wiring to match the following robot & drive/controller manufacturers' cable dress packages

### YOUR CHOICE:

- + ABB
- + Comau
- + Fanuc
- + Kawasaki
- + Kuka
- + Motoman/Yaskawa
- + Nachi
- + Rockwell Automation
- + Bosch-Rexroth
- + Emerson CT
- + WTC-Medar & more

## FEEDBACK CHOICES

- Customer specified to robot manufacturer
- Multi-turn absolute encoder
- Resolver
- Digital encoder

## HIGH THRUST BEARING

Provides complete support of screw with high load rating, maximum rigidity and high strength bearing

## ADVANCED SCREW TECHNOLOGY

- Roller screws provide the highest thrust and life ratings available



## SKewed MOTOR WINDINGS

Skewed motor windings provide minimal torque ripple for force repeatability and smooth linear motion

## IP65



IP65 rating protects actuator from ingress of water, weld slag and other debris (static)

## OPTIONS

**WATER COOLING**  
**REAR TRUNNION MOUNTING**

# ServoWeld - Integrated Motor Actuator

**Table 1: Performance & Mechanical Specifications:**

|                           |   | GSA33, GSA33-GUIDED |       |       | GSA44, GSA04 |           |         |       |        |       | GSA55 |        |
|---------------------------|---|---------------------|-------|-------|--------------|-----------|---------|-------|--------|-------|-------|--------|
|                           |   | MV23/43             |       |       | MV22/42      |           | MV23/43 |       |        |       |       |        |
| SIZE                      | in  | 3.3                 |       |       | 4.4          |           |         |       |        |       | 5.6   |        |
|                           | mm  | 83.0                |       |       | 111          |           |         |       |        |       | 142   |        |
| NUT/SCREW                 |   | RN04                | RN05  | RN10  | RN05         | RN10      | RN04    | RN05  | RN05XR | RN10  | RN05  | RN10   |
| SCREW LEAD                | in  | 0.157               | 0.197 | 0.397 | 0.197        | 0.397     | 0.157   | 0.197 | 0.197  | 0.397 | 0.197 | 0.397  |
|                           | mm  | 4.0                 | 5.0   | 10.0  | 5.0          | 10.0      | 4.0     | 5.0   | 5.0    | 10.0  | 5.0   | 10.0   |
| PEAK FORCE                | lbf   | 2500                | 2500  | 1306  | 3261/2882    | 1630/1441 | 4000    | 3300  | 4000   | 2500  | 8243  | 4121   |
|                           | kN  | 11.1                | 11.1  | 5.8   | 14.5/12.8    | 7.3/6.4   | 17.8    | 14.7  | 17.8   | 11.1  | 36.7  | 18.3   |
| MAX. VELOCITY             | in/sec  | 9.2                 | 11.5  | 23.0  | 11.5         | 23.0      | 9.2     | 11.5  | 11.5   | 23.0  | 7.9   | 15.7   |
|                           | mm/sec  | 234                 | 292   | 584   | 292          | 584       | 234     | 292   | 292    | 584   | 201   | 399    |
| SCREW DYNAMIC LOAD RATING | lbf   | 9240                | 12050 | 10611 | 16479        | 17175     | 15107   | 16479 | 20623  | 17175 | 21716 | 36149  |
|                           | kN  | 41.10               | 53.60 | 47.20 | 73.30        | 76.40     | 67.2    | 73.30 | 91.74  | 76.40 | 96.60 | 160.80 |
| NOMINAL BACK DRIVE FORCE  | lbf   | 98                  | 78    | 39    | 91           | 46        | 114     | 91    | 91     | 46    | 152   | 76     |
|                           | N   | 436                 | 347   | 173   | 405          | 205       | 507     | 405   | 405    | 205   | 676   | 338    |
| AMBIENT TEMP RANGE        | °F  | 50 to 122           |       |       |              |           |         |       |        |       |       |        |
|                           | °C  | 10 to 50            |       |       |              |           |         |       |        |       |       |        |
| IP RATING                 | Standard IP65 (static)  |                     |       |       |              |           |         |       |        |       |       |        |
| AGENCY LISTINGS           |    |                     |       |       |              |           |         |       |        |       |       |        |

**Table 2:**

|                                    |                        | GSA33          | GSA33-GUIDED   | GSA04   |         | GSA44          | GSA55   |
|------------------------------------|------------------------|----------------|----------------|---------|---------|----------------|---------|
|                                    |                        | MV23,43        | MV23,43        | MV22,42 | MV23,43 | MV23,43        | MV23,43 |
| WEIGHT (with 6 in / 152 mm stroke) | lb                     | 18.1           | 28.5           | 29.8    | 32.0    | 35.2           | 67.2    |
|                                    | kg                     | 8.2            | 12.9           | 13.5    | 14.5    | 16.0           | 30.5    |
| STROKE                             | in                     | 6.0 to 18.0    | 6.0 to 9.0     | 6.0     | 6.0     | 6.0 to 18.0    |         |
|                                    | mm                     | 152.4 to 451.2 | 152.4 to 228.6 | 152.4   | 152.4   | 152.4 to 451.2 |         |
| WEIGHT PER UNIT OF STROKE          | lb/in                  | 0.6603         | 0.6603         | 1.1035  | 1.1035  | 1.1035         | 2.1115  |
|                                    | kg/mm                  | 0.0118         | 0.0118         | 0.0197  | 0.0197  | 0.0197         | 0.03771 |
| BASE INERTIA                       | lb/in                  | 1.6723         | 1.6723         | 2.7716  | 3.3442  | 3.3442         | 3.3442  |
|                                    | kg-cm <sup>2</sup>     | 4.8997         | 4.8997         | 8.1108  | 9.7864  | 9.7864         | 9.7864  |
| INERTIA PER UNIT OF STROKE         | lb-in <sup>2</sup> /in | 0.00358        | 0.00358        | 0.00984 | 0.00984 | 0.00984        | 0.00984 |
|                                    | kg-cm <sup>2</sup> /mm | 0.00041        | 0.00041        | 0.00113 | 0.00113 | 0.00113        | 0.00113 |

**MV23,43 = 3 Stack Motor**  
**MV22,42 = 2 Stack Motor**

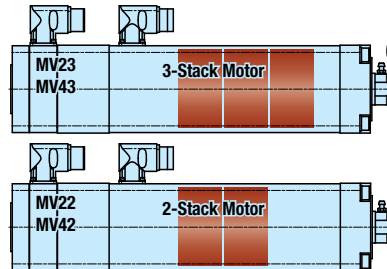

**RoHS COMPLIANT** RoHS Compliant Components,

**CE Approved**

# ServoWeld - Integrated Motor Actuator

**Table 3: Motor Specifications:**

|                                 |                    | GSA33         |      | GSA04 |       | GSA44 |       | GSA55 |      |      |
|---------------------------------|--------------------|---------------|------|-------|-------|-------|-------|-------|------|------|
|                                 |                    | GSA33, GUIDED |      |       |       | GSA04 |       |       |      |      |
|                                 |                    |               |      | MV23  | MV43  | MV22  | MV42  | MV23  | MV43 | MV23 |
| <b>BUS VOLTAGE</b>              | $V_{RMS}$          | 230           | 460  | 230   | 460   | 230   | 460   | 230   | 460  |      |
| <b>TORQUE CONSTANT (KT)</b>     | in-lb/A Peak       | 5.5           | 10.7 | 4.6   | 8.0   | 5.4   | 10.6  | 6.7   | 13.4 |      |
|                                 | N-m/A Peak         | 0.62          | 1.21 | 0.52  | 0.90  | 0.61  | 1.2   | 0.76  | 1.51 |      |
| <b>VOLTAGE CONSTANT (KE)</b>    | V/Krpm Peak        | 79.8          | 154  | 66.1  | 107.2 | 78.1  | 153.1 | 100   | 201  |      |
| <b>CONTINUOUS STALL TORQUE</b>  | No Water Cooling   | in-lb         | 39   | 38    | 48.8  | 43.0  | 74    | 75    | 112  | 112  |
|                                 |                    | N-m           | 4.4  | 4.3   | 5.5   | 4.9   | 8.4   | 8.5   | 12.7 | 12.7 |
|                                 | With Water Cooling | in-lb         | 78   | 76    | 97.6  | 86    | 148   | 150   | NA   | NA   |
|                                 |                    | N-m           | 8.8  | 8.6   | 11.0  | 9.7   | 16.7  | 17.0  | NA   | NA   |
| <b>CONTINUOUS STALL CURRENT</b> | No Water Cooling   | $A_{RMS}$     | 5.0  | 2.5   | 7.5   | 3.8   | 9.7   | 5.0   | 11.8 | 5.9  |
|                                 | With Water Cooling | $A_{RMS}$     | 10.0 | 5.0   | 15.0  | 7.6   | 19.4  | 10.0  | NA   | NA   |
| <b>PEAK TORQUE</b>              | in-lb              | 117           | 114  | 146   | 129   | 222   | 225   | 335   | 335  |      |
|                                 | N-m                | 13.2          | 12.9 | 16.5  | 14.6  | 25.1  | 25.4  | 37.8  | 37.8 |      |
| <b>PEAK CURRENT</b>             | $A_{RMS}$          | 15            | 7.5  | 22.5  | 11.4  | 29.1  | 15.0  | 35.4  | 17.7 |      |
| <b>RESISTANCE</b>               | Ohms               | 2.07          | 8.3  | 0.9   | 4.2   | 0.58  | 2.32  | 0.57  | 2.93 |      |
| <b>INDUCTANCE</b>               | mH                 | 3.8           | 15.0 | 3.65  | 15.7  | 2.75  | 11.5  | 1.4   | 5.8  |      |
| <b>SPEED @ RATED V</b>          | RPM                | 3,500         |      |       |       |       |       | 2,400 |      |      |
| <b>NO. OF POLES</b>             |                    | 8             |      |       |       |       |       |       |      |      |

## BRAKE CONSIDERATIONS

In all vertical application an un-powered ServoWeld actuator will require a brake to maintain position. Tolomatic recommends that the nominal back drive force specification (listed in Table 1) be used for reference only. Back drive force is subject to change throughout the life of the actuator, due to mechanical break in, ambient temperature, and duty cycle variation.



Brake will increase actuator length and weight

A brake can be used with the actuator to keep it from back-driving, typically in vertical applications. A brake may be used for safety reasons or for energy savings allowing the actuator to hold position when un-powered.

NOTE: The optional Spring-Applied / Electronically-Released Brake requires 24V power.

**Table 4: Brake Specifications:**

|                       |                    | SERIES | GSA33 | GSA44 & GSA04 | GSA55 |
|-----------------------|--------------------|--------|-------|---------------|-------|
| <b>ROTOR INERTIA</b>  | oz-in <sup>2</sup> |        | 0.400 | 1.307         | 1.171 |
|                       | gm-cm <sup>2</sup> |        | 73    | 239           | 214   |
| <b>CURRENT</b>        | Amp                |        | 0.43  | 0.67          | 0.66  |
| <b>HOLDING TORQUE</b> | in-lb              |        | 35    | 89            | 145   |
|                       | N-m                |        | 4.0   | 9.0           | 16.4  |
| <b>ENGAGE TIME</b>    | mSec               |        | 40    | 25            | 15    |
| <b>DISENGAGE TIME</b> | mSec               |        | 50    | 35            | 25    |
| <b>VOLTAGE</b>        | Vdc                |        | 24    |               |       |

## SIDE LOADING

Some weld gun designs may subject the actuator to excessive side loading reducing overall service life. The GSA33, GUIDED actuator (page 8) will accommodate side loading. For other ServoWeld configurations measures are required, especially in "C" style designs, to limit side loading. For life optimization Tolomatic recommends side loads less than indicated in the graph below.

## DISTANCE TRAVELED UNDER LOAD

Distance traveled under load is a derivative of weld gun deflection/spring rate. Tests demonstrate the overall service life of actuators is extended when travel distance under load is minimized.

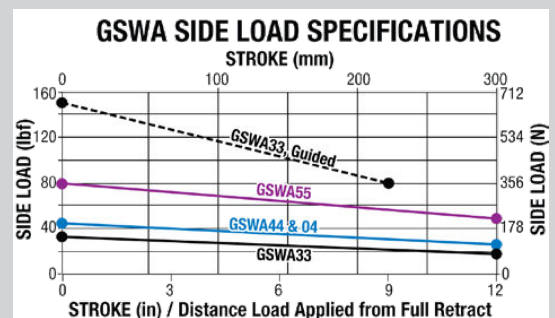

When these service life factors are considered at the design phase, millions of trouble free cycles are possible. Please contact Tolomatic for more information.

# GSWA Dimensions

## Dimensions: GSWA33

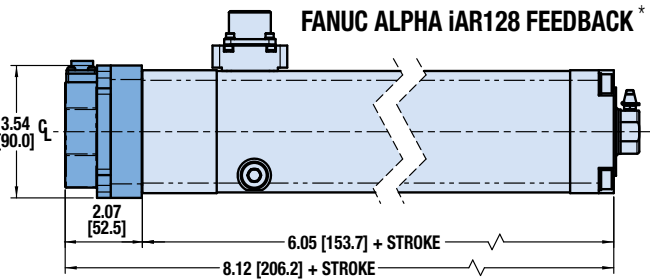
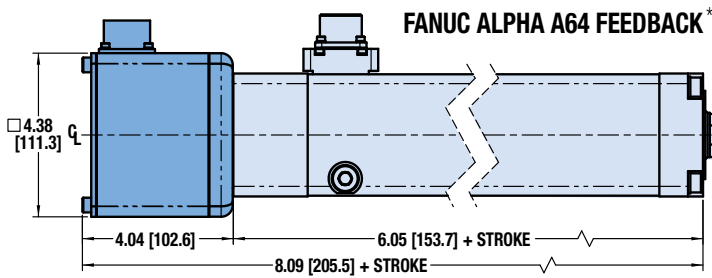
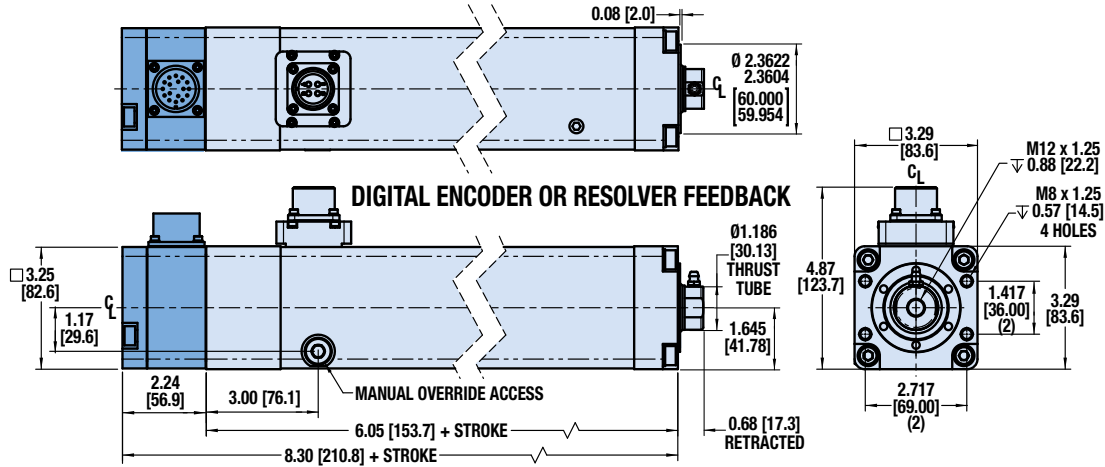

## Dimensions: GSWA44

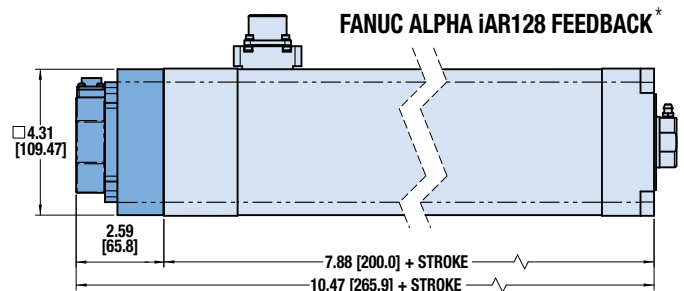
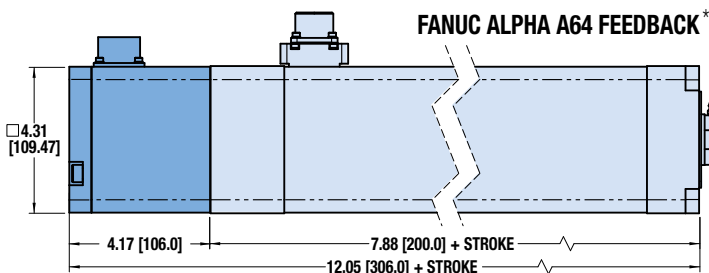
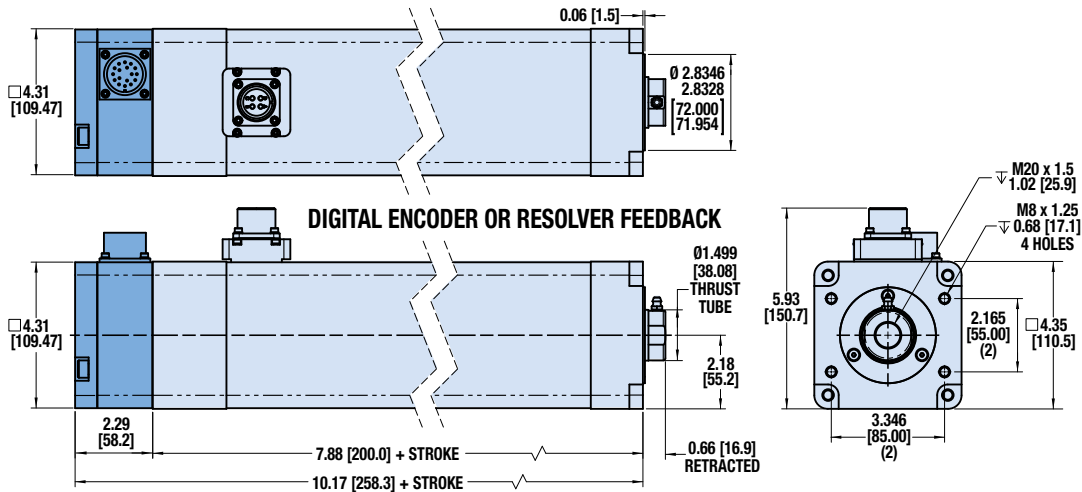

\*Shown fully assembled with customer supplied feedback

# GSWA - Dimensions

## Dimensions: GSWA33, Guided

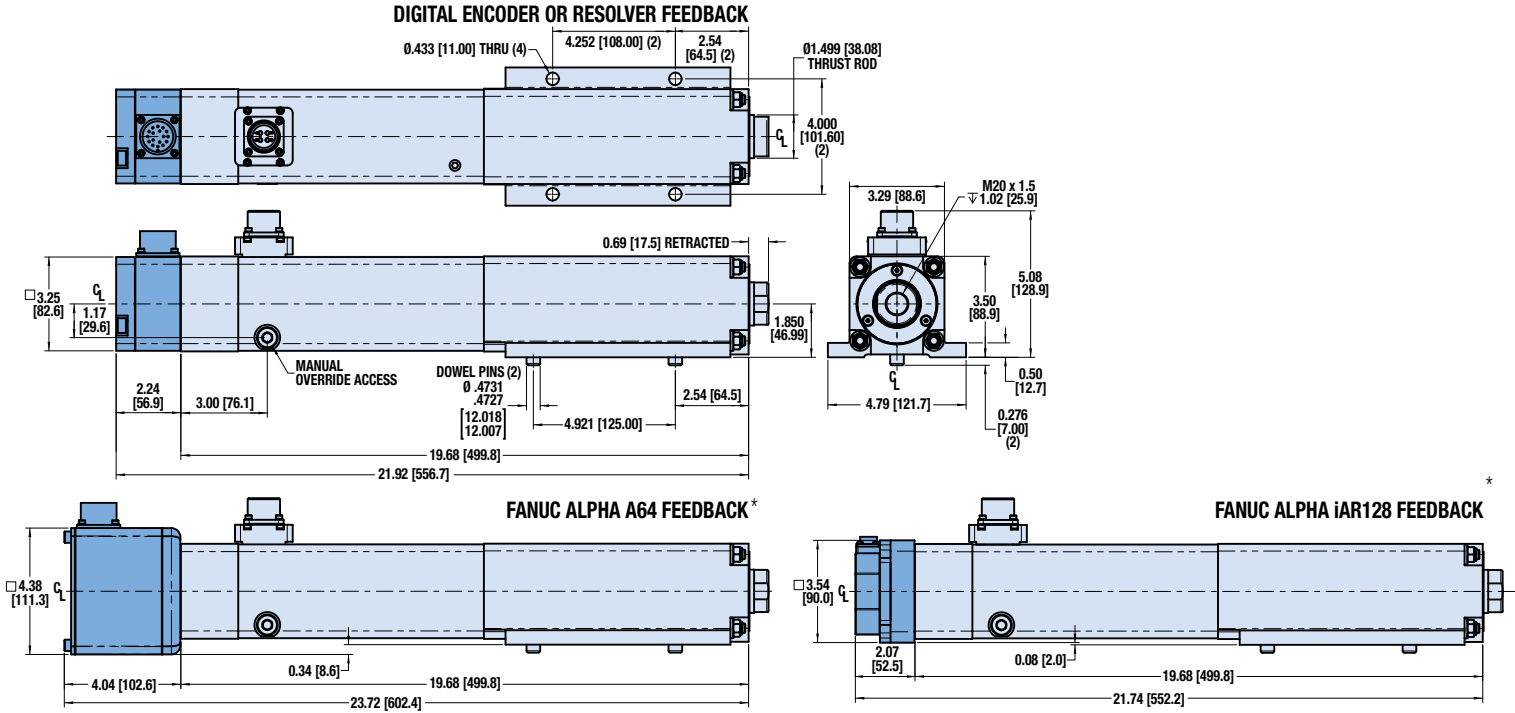

## Dimensions: GSWA 04

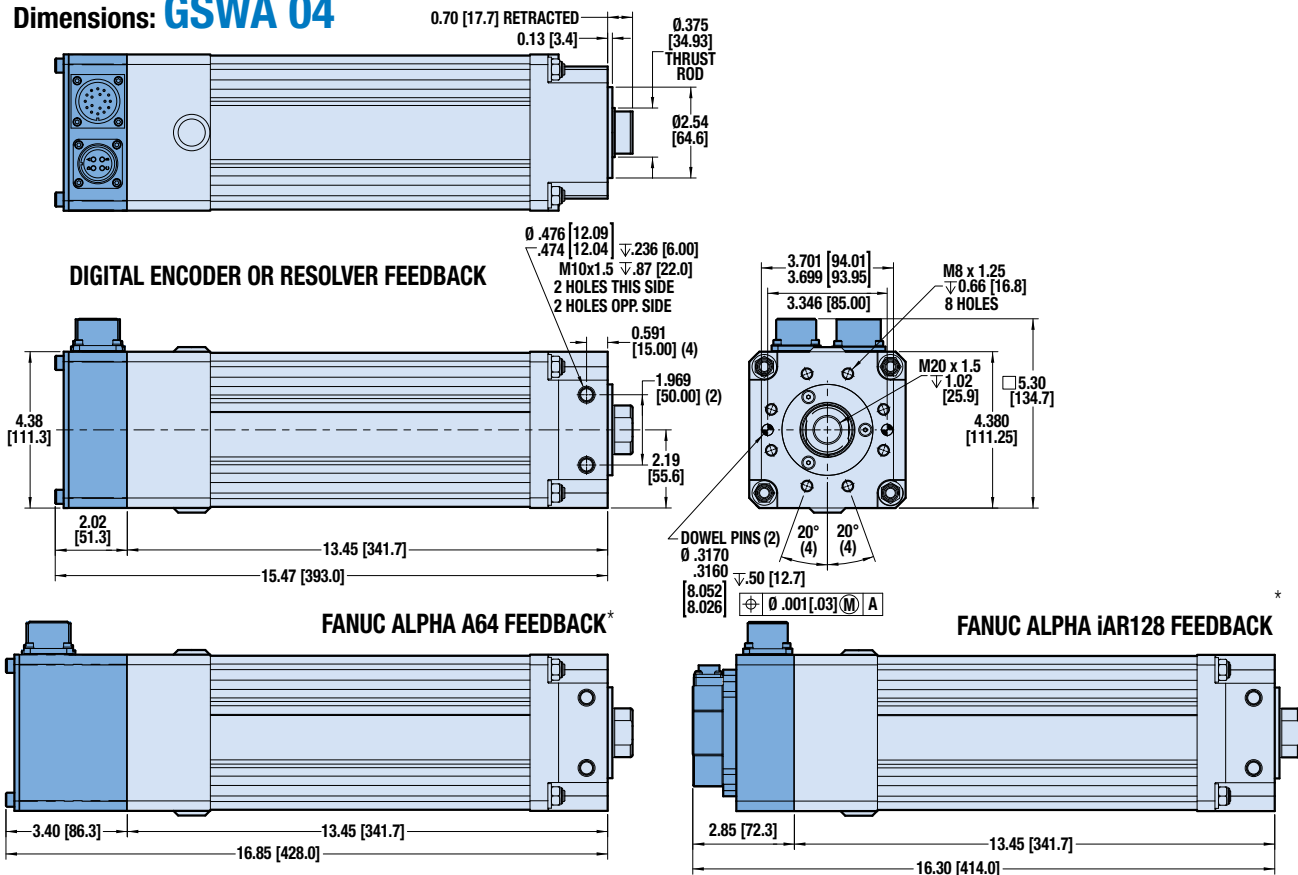

\*Shown fully assembled with customer supplied feedback

Contact Tolomatic for GSWA55 dimensions

# Complete Verification Testing is Performed on Every Actuator

## **EVERY SERVOWELD ACTUATOR HAS TO PASS RIGOROUS TESTING AT OUR FACTORY.**

We verify the performance of each individual unit before delivery to ensure they conform to Tolomatic's high standard of performance.



*Functional unit testing for hundreds of cycles quantifies stroke, length, torque under no load, input current vs force standard deviation.*

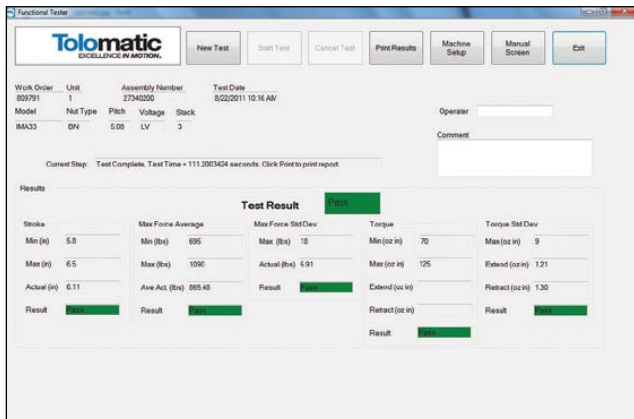

*Testing parameter results in progress for the Functional Test procedure.*



*Final system test ensures the feedback device is properly aligned with the ServoWeld motor poles.*

### **1. High POT (High Potential/High Voltage Test)**

This standard electric motor test procedure is a 3-part test that checks the insulation system of the assembly to verify proper armature and thermal wire insulation.

### **2. Electronic phasing of ServoWeld® and feedback device (Encoder, Resolver, Feedback Device)**

Using a fixed current and a specially designed fixture the feedback device is physically and electronically aligned relative to the phasing of the Tolomatic motor.

### **3. Functional Testing**

Performed with Tolomatic motion control components and dedicated data acquisition equipment. Operated for hundred of cycles, this test quantifies these parameters - stroke length, torque under no load, input current vs force average, input current vs force standard deviation - using an electronic load cell in conjunction with data acquisition equipment.

### **4. Tolomatic System Test**

Using a single-axis control unit the test ensures that the feedback device is properly aligned with the poles of the Tolomatic motor.

# ServoWeld Application Guidelines

**SIDE LOADING:** Weld gun designs may subject the actuator to excessive side loading, reducing overall service life. The GSWA33 and CSW(x) Guided actuators will accommodate side loading caused by the mass of the electrode, misaligned weld tips and tip skid. For other ServoWeld configurations additional measures are required to limit side loading, especially in “C” style gun designs. For maximum service life, external guiding is recommended to minimize side loading to the thrust rod and provide consistent weld gun alignment throughout the service life. Reference the side load capacity charts in the GSWA, SWA/SWB, and CSW(x) manuals and/or brochures.

**THRUST ROD WIPER/SCRAPER:** For maximum service life, measures should be taken to reduce/eliminate contamination, weld slag, and water in the thrust rod wiper/scraper interface area. Implementation of industrial thrust rod boot and/or deflective device can be effectively utilized in this area.

**CABLES:** Shielded power & feedback cables are recommended to minimize electrical noise/grounding issues. Electrical noise or inadequate grounding can corrupt the feedback device signal.

**RSW SERVO SYSTEM CALIBRATION:** RSW weld gun servo system consists of robot 7th axis amplifier, robot feedback device, robot RSW software, weld gun chassis, & ServoWeld.

For optimal RSW weld gun servo system performance the calibration process should include maximum weld tip force from the production weld schedule, tip dress force, and multiple weld tip forces in-between. Utilizing all the available robot manufacturer force table inputs will provide best RSW weld gun servo system performance. The same weld tip part contact speed should be used for both RSW weld gun servo system calibration and production weld schedule.

**WELD TIP / PART CONTACT SPEED:** Tolomatic testing confirms the highest ServoWeld repeatability (**INPUT**

**CURRENT** verses **OUTPUT FORCE**) at a weld tip part contact speed of 25mm/second or less. Speeds greater than 25mm/second can create “impact contribution” to the weld force. This impact contribution to the weld force deteriorates prior to completion of the weld cycle.

**ROBOT CARRIED APPLICATIONS:** Robot carried RSW gun applications have reduced exposure to water pooling/water ingress by virtue of the continuous robot movement and various RSW gun positions. In addition, in robot carried applications positioning of the RSW gun can be programmed as part of the weld cap change program/routine to eliminate ServoWeld exposure to water. (ServoWeld above weld caps)

**ROBOT MANUFACTURER SERVO FILE:** Robot manufacturer servo parameter files for operation of ServoWeld are available only from the robot manufacturer. Each robot manufacturer creates 3rd party motor servo parameter files, validates operation of ServoWeld via their 7th axis, and maintains servo motor parameter file for operation of ServoWeld.

**TOOL CHANGER APPLICATIONS:** Weld gun storage fixture in cell should position weld gun so movable electrode is not loading ServoWeld thrust rod - back driving the ServoWeld. Weld gun tips should be positioned to weld gun closed at low force prior to disconnect from robot/tool changer. Consider ServoWeld configured with integral brake option.

**FIXED / PEDESTAL APPLICATIONS:** One of the more challenging RSW applications is a pedestal RSW gun, ServoWeld mounted vertical – thrust rod up. Measures should be taken to reduce and/or eliminate the ServoWeld to water exposure, water pooling/spray in the access areas of the ServoWeld unit to maximize overall service life.

# The Tolomatic Difference Expect More From the Industry Leader:



## INNOVATIVE PRODUCTS

Solutions with Endurance Technology<sup>SM</sup> for challenging applications.



## FAST DELIVERY

Built-to-order with configurable stroke lengths and flexible mounting options.

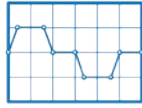

## ACTUATOR SIZING

Size and select electric actuators with our online software.



## YOUR MOTOR HERE<sup>®</sup>

Match your motor to compatible mounting plates with Tolomatic actuators.



## CAD LIBRARY

Download 2D or 3D CAD files for Tolomatic products.



## TECHNICAL SUPPORT

Get a question answered or request a virtual design consultation with one of our engineers.

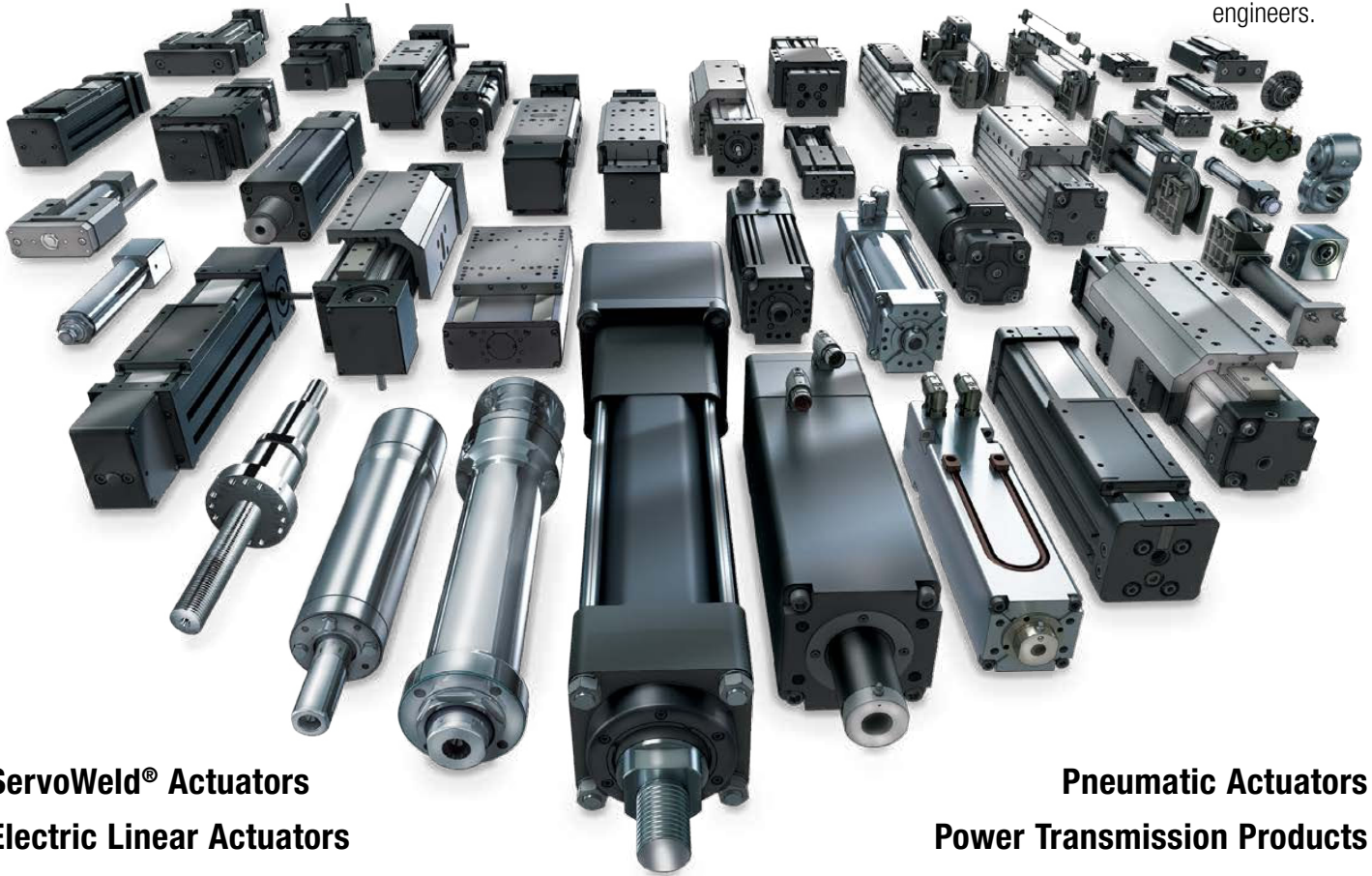

**ServoWeld<sup>®</sup> Actuators**  
**Electric Linear Actuators**

**Pneumatic Actuators**  
**Power Transmission Products**



MADE IN U.S.A.

# Tolomatic<sup>TM</sup>

EXCELLENCE *IN MOTION*

COMPANY WITH  
QUALITY SYSTEM  
CERTIFIED BY DNV  
= ISO 9001 =  
Certified site: Hamel, MN

### USA - Headquarters

**Tolomatic Inc.**  
3800 County Road 116  
Hamel, MN 55340, USA  
**Phone:** (763) 478-8000  
Toll-Free: **1-800-328-2174**  
sales@tolomatic.com  
[www.tolomatic.com](http://www.tolomatic.com)

### MEXICO

**Centro de Servicio**  
Parque Tecnológico Innovación  
Int. 23, Lateral Estatal 431,  
Santiago de Querétaro,  
El Marqués, México, C.P. 76246  
**Phone:** +1 (763) 478-8000  
help@tolomatic.com

### EUROPE

**Tolomatic Europe GmbH**  
Elisabethenstr. 20  
65428 Rüsselsheim  
Germany  
**Phone:** +49 6142 17604-0  
help@tolomatic.eu  
[www.tolomatic.com/de-de](http://www.tolomatic.com/de-de)

### CHINA

**Tolomatic Automation Products (Suzhou) Co. Ltd.**  
No. 60 Chuangye Street, Building 2  
Huqiu District, SND Suzhou  
Jiangsu 215011 - P.R. China  
**Phone:** +86 (512) 6750-8506  
Tolomatic\_China@tolomatic.com

All brand and product names are trademarks or registered trademarks of their respective owners. Information in this document is believed accurate at time of printing. However, Tolomatic assumes no responsibility for its use or for any errors

that may appear in this document. Tolomatic reserves the right to change the design or operation of the equipment described herein and any associated motion products without notice. Information in this document is subject to change without notice.

Visit [www.tolomatic.com](http://www.tolomatic.com) for the most up-to-date technical information