

TRS

TWIN PROFILE RAIL STAGE

STROKE CONFIGURABLE ACTUATOR



TRS225

TRS165

TRS100

**ENCLOSED DESIGN
PROFILED RAIL ACTUATOR**

TRS Twin Rail Stage Actuator

TRS: A Rugged, Accurate Stage

The TRS is a highly capable stage product and is the perfect for a base in multi-axis systems. The machined, rigid design handles high moment loading while providing reliable positioning along the length of travel.

Maximum flexibility is achieved through stroke configurable design, ensuring the right stroke length can be selected to minimize footprint. Online CAD and Sizing tools enable rapid design iterations throughout the design process.

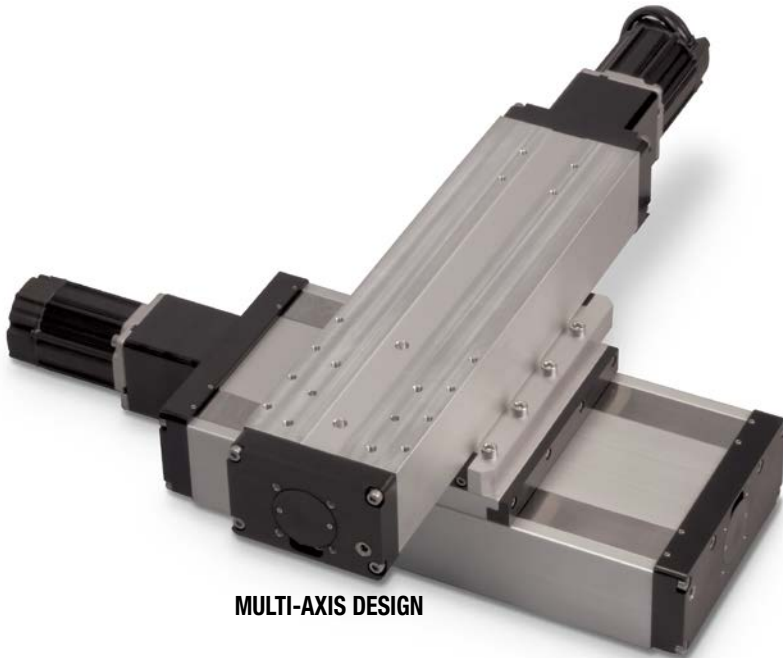

MULTI-AXIS DESIGN

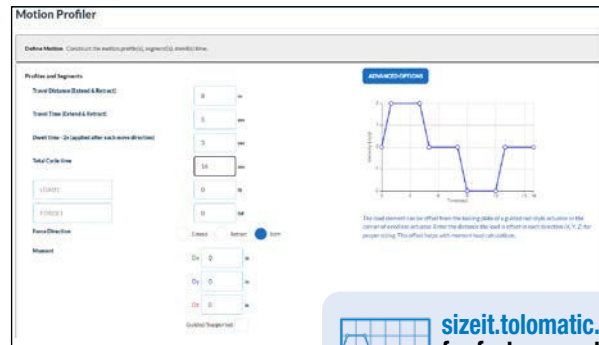

sizeit.tolomatic.com
for fast, accurate
actuator selection

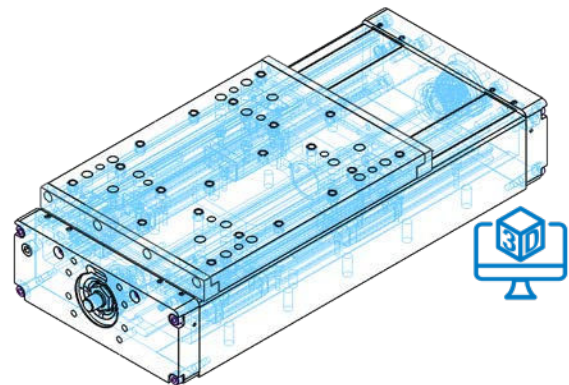

A Comparison of Screw Drive Actuators

	TRS	B3S	MXE-S	MXE-P
Features:	Superior rigidity, high moment load capacities	Internal bearing, highest load and bending moments	Basic guidance and support	High load and bending moment capacities
Load up to: <i>(with options)</i>	4,320 lb [1,960 kg]	8,000 lb [3,629 kg]	1,040 lb [472 kg]	2,584 lb [1,172 kg]
Thrust up to:	2,830 lbf [12.6 kN]	2,700 lbf [12 kN]	4,300 lbf [19.1 kN]	4,300 lbf 19.1 kN]
Speed up to:	50 in/sec [12,70 mm/sec]	60 in/sec [1,500 mm/sec]	60 in/sec [1,500 mm/sec]	60 in/sec [1,500 mm/sec]
Stroke Length up to:	87 in [2,200 mm]	179 in [4,550 mm]	179 in [4,550 mm]	179 in [4,550 mm]
Screw/Nut Type	Ball & Roller	Solid & Ball	Solid & Ball	Solid & Ball
www.tolomatic.com for complete information, search by literature number:				
Literature Number:	3600-4222	3600-4176	8300-4000	8300-4000

(Not all models deliver ALL maximum values listed, i.e.: Maximum thrust may not be available with maximum speed)

TRS Twin Rail Stage Actuator

Storage & Retrieval

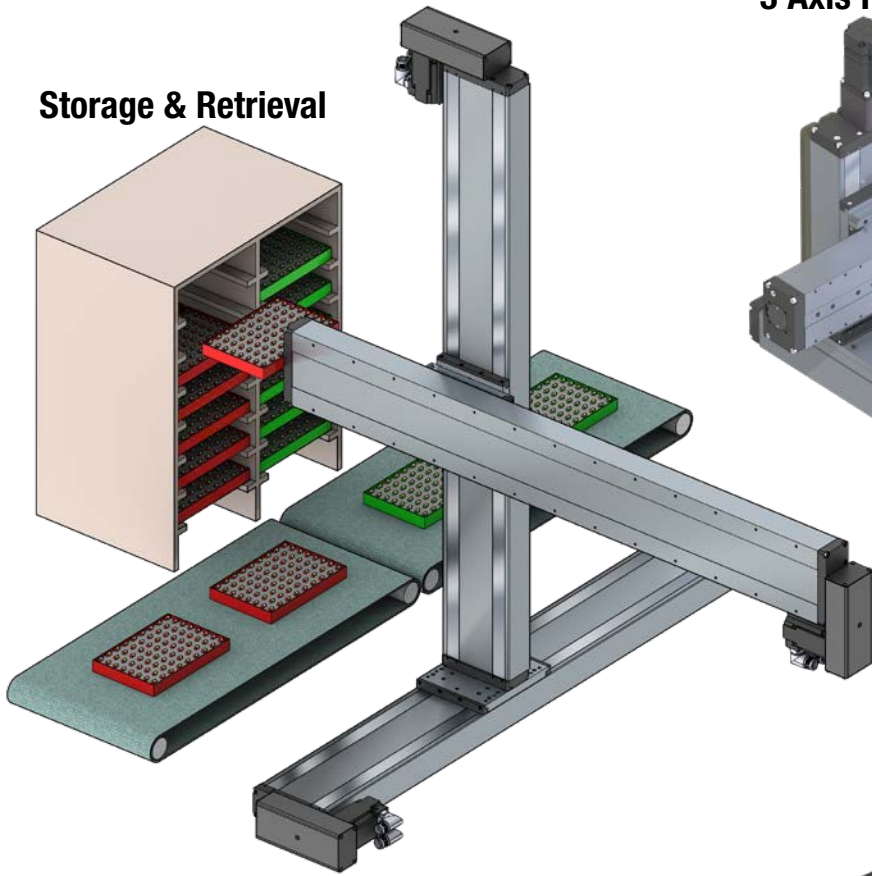

3 Axis Positioning

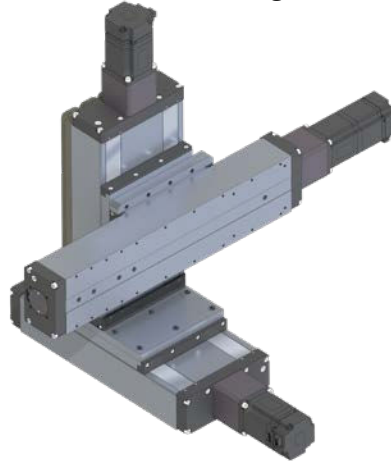

CONTENTS

Rodless ComparisonTRS_2

Applications.....TRS_3

TRS FeaturesTRS_3

TRS SpecificationsTRS_6

TRS Dimensions.....TRS_11

SwitchesTRS_13

Application Data
Worksheet.....TRS_17

Selection Guidelines ...TRS_18

TRS OrderingTRS_19

Other Tolomatic
Products.....TRS_20

Robot Arm Positioning

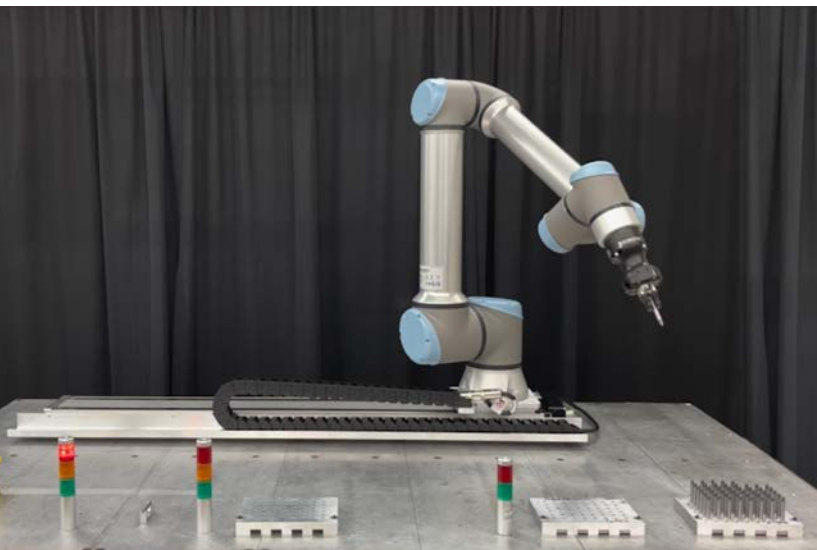

Laser Engraving

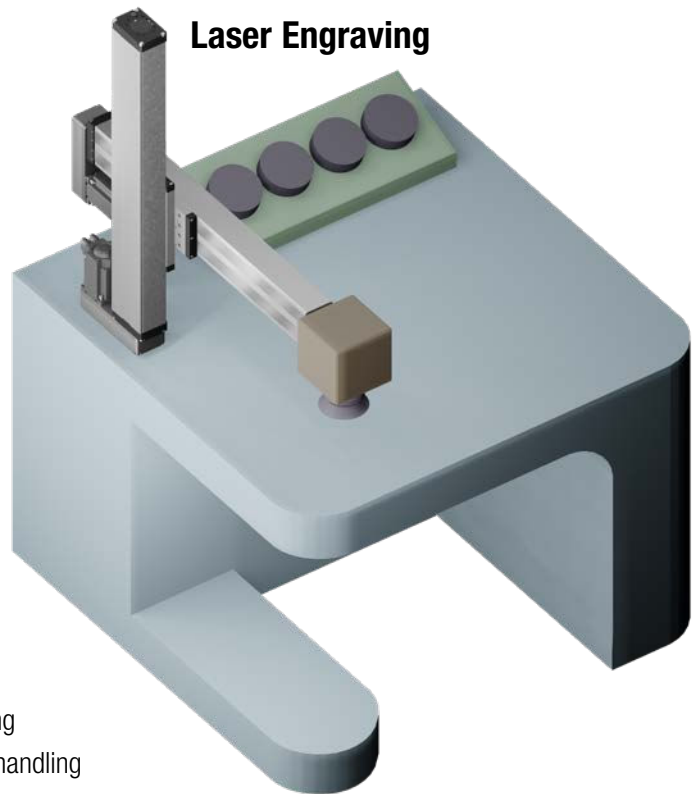

- Inspection and measurement
- Medical equipment
- Pick and place
- Precision grinders
- Stage motion control
- Table positioning
- Test stands
- Machine centers
- Machine tools
- Drilling
- Cutting
- Positioning
- Material handling systems
- Pick and place
- X Y Z axis (2 and 3 axis configurations)

TWIN RAIL STAGE ENCLOSED DESIGN PROFILED RAIL ACTUATOR

ENDURANCE TECHNOLOGY

A Tolomatic Design Principle

REDUCE UNPLANNED DOWNTIME: Endurance Technology features are designed for maximum durability to provide extended service life.

The TRS Twin profile rail stage with enclosed design is built from the ground up to be highly rigid and accurate. Available in 100, 165 and 225 sizes and capable of handling loads up to 4,320 lb (1,960 kg). To maximize design flexibility, the TRS actuator is stroke configurable to minimize overall machine footprint.

HIGH RIGIDITY

Twin rails each with 2 bearings minimizes deflection for reliable and accurate positioning along the length of travel

CARRIER TO CARRIER OR BASE MOUNTING

- Build a multi-axis system with reduced components by leveraging this standard mounting option
- Tolomatic representatives are available to assist with the sizing

YOUR MOTOR HERE

- For maximum design flexibility, specify the motor or gearbox to be installed with in-line or reverse parallel mounting.
- For out of the box installation, the TRS actuator ships with the proper mounting hardware

MULTIPLE SCREW TECHNOLOGIES

ROLLER NUT

Roller nuts provide the highest thrust and life ratings available



BALL NUT

Ball nuts offer efficiency at a cost effective price



SCREW ACCURACY

± 0.0102mm/300mm; ± 0.0004"/ft.

SCREW ACCURACY

± 0.051mm/300mm; ± 0.002"/ft.

BREATHER/PURGE PORTS

Positive pressure with air lines and filters helps reduce contamination of the interior of the actuator

IP44 RATED WITH STAINLESS STEEL DUST BANDS

- Perfect for industrial environments
- Limits the amount of contaminants that enter the actuator, which protects components for reduced maintenance and increased uptime

STANDARD MOUNTING FEATURES

- **Threaded mounting holes:** Evenly spaced along the base of the actuator
- **Dowel pin holes:** Ensures the actuator can be aligned without additional modification

CLEAN SMOOTH DESIGN

- Smooth and flat surface to create the cleanest sealing design in the industry
- Wiper and seal are integrated in carrier design to enable clean and smooth operation

OPTIONAL TOE CLAMP MOUNTING

Slot and clamps provide convenient mounting option for fast installation



OPTIONAL SWITCH WITH RAIL

- 12 switch choices in normally open or closed; with flying leads or quick-disconnect



- Easily adjust the location of switches along the length of the actuator

OPTIONAL MID-SCREW SUPPORT

- Optional Mid-Screw Support for faster travel speeds with longer stroke lengths

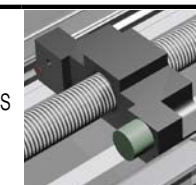

TRS Twin Rail Stage Actuator

sizeit.tolomatic.com
for fast, accurate
actuator selection

BENDING MOMENTS

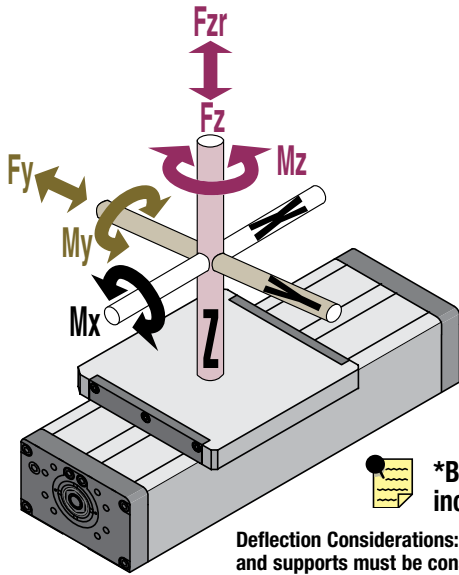

MAX. BENDING MOMENTS AND LOADS*								
		Metric			U.S. Conventional			
Max. Bending Moments		100	165	225		100	165	225
Mx (Roll)	N-m	105	294	1,180	lb-in	932	2,604	10,448
My (Pitch)	N-m	256	348	1,610	lb-in	2,266	3,084	14,247
Mz (Yaw)	N-m	231	315	1,454	lb-in	2,047	2,785	12,868
Max. Loads								
Fz (Radial)	kg	492	615	1,960	lb	1,085	1,356	4,320
Fzr (Reverse Radial)	kg	421	526	1,521	lb	928	1,160	3,352
Fy (Lateral)	kg	380	475	1,684	lb	838	1,048	3,712

*Bending moments & load specifications are based on (5,000 kM) 200,000,000 linear inches of carrier travel.

Deflection Considerations: In applications where substantial Mx or My moments come into play, deflection of the actuator frame, carrier and supports must be considered. The deflection values shown in the Load Deflection charts, are based on actuator mounted with its base fully restrained to a surface.

LOAD DEFLECTION

DEFLECTION ABOUT THE Y-AXIS

DEFLECTION ABOUT THE X-AXIS

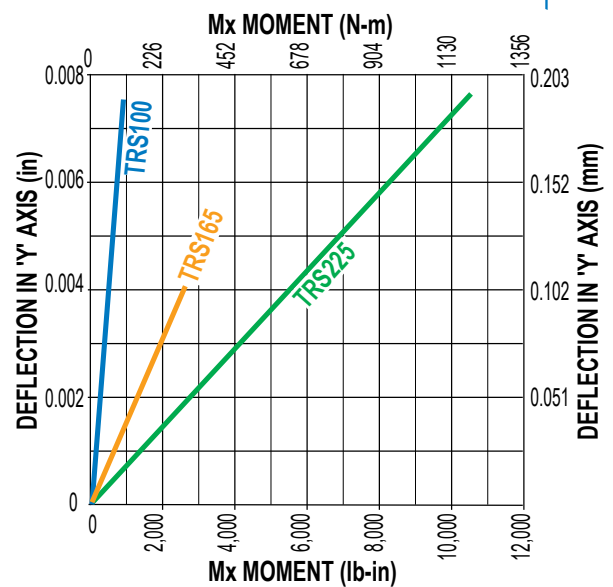
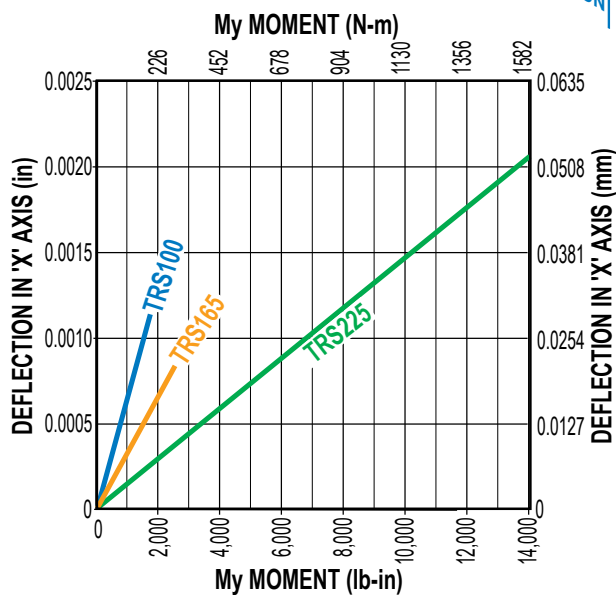
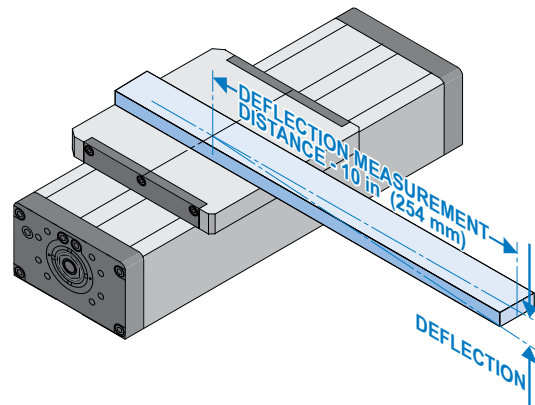
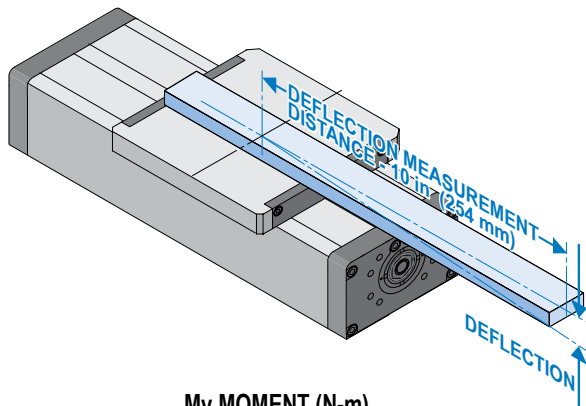

TRS Twin Rail Stage Actuator



TRS SPECIFICATIONS

SPECIFICATIONS RELATED TO ACTUATOR SIZE AND SCREW SELECTION

TRS LEAD SCREWS METRIC												
ACTUATOR	SCREW CODE	LEAD (mm)	LEAD ACCURACY (mm/300)	BACKLASH (mm)	MAXIMUM THRUST (N)	MAXIMUM STROKE (mm)	INERTIA					DYNAMIC FRICTION TORQUE (N-m)
							BASE ACTUATOR				PER/in OF STROKE	
							Inline	Inline HT	RP1	RP2		
							(kg-m ² x 10 ⁻⁶)					
TRS100	BNM05	5	0.100	0.07 - 0.12	3,870	750	40.82	—	135.32	—	1.29	0.18
	BNM10	10	0.100	0.07 - 0.12	2,710	750	45.35	—	139.85	—	1.29	0.19
TRS165	BNM05	5	0.100	0.07 - 0.12	3,870	1,100	40.67	—	135.17	—	1.29	0.18
	BNM10	10	0.100	0.07 - 0.12	2,710	1,100	43.30	—	137.80	—	1.29	0.19
	RN05	5	0.010	0.03	5,690	557	38.48	—	132.98	—	0.99	0.21
	RN10	10	0.010	0.03	2,850	557	41.67	—	136.16	—	0.99	0.21
TRS225	BNM05	5	0.050	0.05 - 0.13	9,880	2,200	168.4	283.3	651.4	234.8	7.48	0.49
	BNM10	10	0.050	0.05 - 0.13	9,390	2,200	184.5	299.3	667.4	238.9	7.48	0.49
	BN01	25.4	0.182	0.13 - 0.38	3,690	2,200	305.8	420.6	788.7	269.2	7.98	0.49
	RN04	4	0.010	0.03	12,590	793	72.7	187.6	555.2	210.8	2.95	0.49
	RN05	5	0.010	0.03	12,590	793	74.7	189.6	557.2	211.3	2.95	0.49
	RN10	10	0.010	0.03	9,390	793	90.7	205.6	573.2	215.3	2.95	0.49

TRS LEAD SCREWS U.S. CONVENTIONAL												
ACTUATOR	SCREW CODE	LEAD (turns/in)	LEAD ACCURACY (in/ft)	BACKLASH (in)	MAXIMUM THRUST (lbf)	MAXIMUM STROKE (in)	INERTIA					DYNAMIC FRICTION TORQUE (lb-in)
							BASE ACTUATOR				PER/in OF STROKE	
							Inline	Inline HT	RP1	RP2		
							(lb-in ²)					
TRS100	BNM05	5.08	0.0040	0.0028 - 0.0050	870	29.5	0.1397	—	0.4631	—	0.0044	1.56
	BNM10	2.54	0.0040	0.0028 - 0.0050	610	29.5	0.1552	—	0.4786	—	0.0044	1.69
TRS165	BNM05	5.08	0.0040	0.0028 - 0.0050	870	43.3	0.1392	—	0.4626	—	0.0044	1.56
	BNM10	2.54	0.0040	0.0028 - 0.0050	610	43.3	0.1482	—	0.4716	—	0.0044	1.69
	RN05	5.08	0.0004	0.0012	1,280	21.9	0.1317	—	0.4551	—	0.0034	1.88
	RN10	2.54	0.0004	0.0012	640	21.9	0.1426	—	0.466	—	0.0034	1.88
TRS225	BNM05	5.08	0.0020	0.0020 - 0.0050	2,220	86.6	0.5765	0.9696	2.2294	0.8037	0.0256	4.38
	BNM10	2.54	0.0020	0.0020 - 0.0050	2,110	86.6	0.6313	1.0244	2.2842	0.8174	0.0256	4.38
	BN01	1.00	0.0070	0.0050 - 0.0150	830	86.6	1.0465	1.4396	2.6993	0.9212	0.0273	4.38
	RN04	6.35	0.0004	0.0012	2,830	31.2	0.2489	0.6420	1.9001	0.7214	0.0101	4.38
	RN05	5.08	0.0004	0.0012	2,830	31.2	0.2556	0.6487	1.9068	0.7231	0.0101	4.38
	RN10	2.54	0.0004	0.0012	2,110	31.2	0.3104	0.7035	1.9616	0.7368	0.0101	4.38



Contact the factory for higher accuracy and lower backlash options.

SCREW CODE	DESCRIPTION
BN	Ball Nut
BNM	Ball Nut Metric
RN	Roller Nut

TRS Twin Rail Stage Actuator



ACTUATOR SPECIFICATIONS

		TRS100		TRS165				TRS225					
		Ball Nut		Ball Nut		Roller Nut		Ball Nut			Roller Nut		
		LMI	RP	LMI	RP	LMI	RP	LMI	LMI HT	RP	LMI	LMI HT	RP
Carrier Assy Weight	kg	2.2	2.2	3.2	3.2	3.6	3.6	8.5	8.5	8.5	8.7	8.7	8.7
Base Wgt. (incl. carrier)	kg	6.0	7.8	8.4	10.3	8.7	10.6	21.7	22.7	24.1	22.2	23.2	24.5
Wgt. per unit of stroke	kg/mm	0.010	0.010	0.015	0.015	0.014	0.014	0.028	0.028	0.028	0.027	0.027	0.027
Carrier Assy Weight	lb	4.8	4.8	7.1	7.1	7.8	7.8	18.7	18.7	18.7	19.1	19.1	19.1
Base Wgt. (incl. carrier)	lb	13.2	17.2	18.6	22.6	19.3	23.3	47.9	50.1	53	48.9	51.1	54
Wgt. per unit of stroke	lb/in	0.56	0.56	0.81	0.81	0.80	0.80	1.6	1.6	1.6	1.5	1.5	1.5
Temperature Range*		4-54 °C; 40-130 °F											

*For applications that require operation outside of the recommended temperature range, contact the factory.

STRAIGHTNESS AND FLATNESS

Length of Travel	mm	60	120	180	240	300	360	420	480	540	600	660	720	780	840	900	960	1,020	1,080	1,100
	in	2.4	4.7	7.1	9.5	11.8	14.2	16.5	18.9	21.3	23.6	26.0	28.4	30.7	33.1	35.4	37.8	40.2	42.5	43.3
Straightness/Flatness	µm	20	21	22	23	24	26	27	28	29	30	32	33	34	35	36	38	39	40	40



• Listed values are intended for reference purposes only, and not as an engineering standard of absolute tolerance for a given actuator. Reference values are measured in ideal conditions. Actual values in the field may vary due to temperature, mounting surface, or other environmental factors.

TRS CARRIER TO CARRIER MAX. LOAD

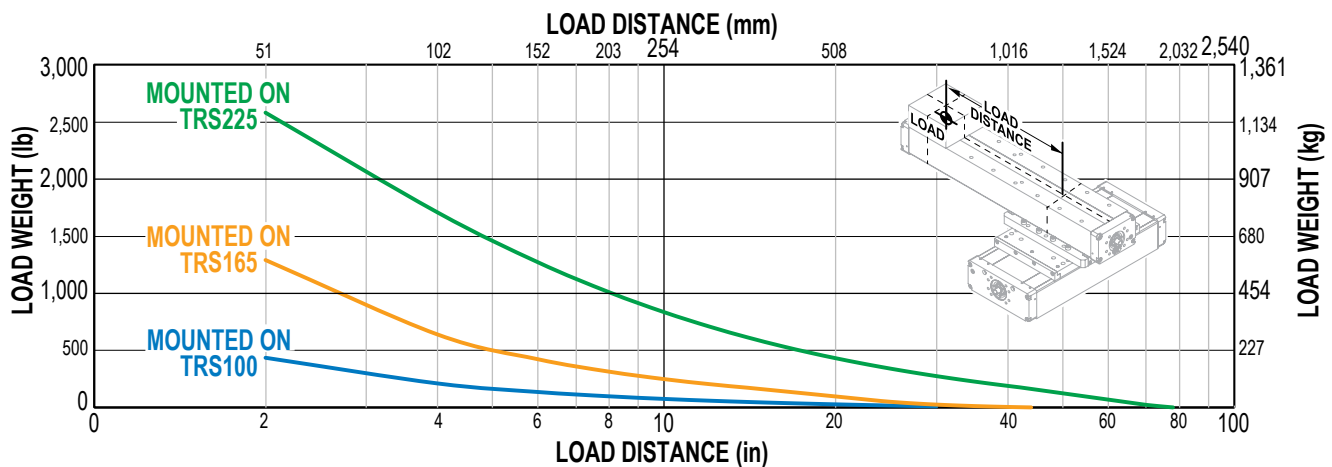

Carrier to Carrier (C2C) mounting

Allows connection of two actuator perpendicular to each other via the carriers

Available on the TRS100 to mount to a TRS165, or another TRS100 with the C2C option

Available on TRS225 to mount to another TRS225

TRS100 C2C to TRS100 TRS100 C2C to TRS165

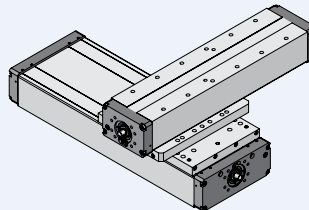

TRS225 C2C to TRS225

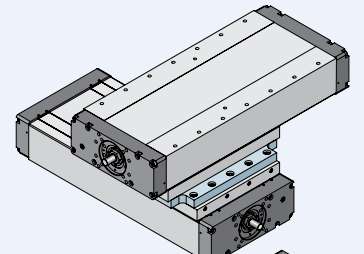

Carrier to Base (C2B) mounting

Allows connection of two actuator perpendicular to each other via the carrier and base

Only available on TRS225 and allows connection to another TRS225 only.



Other combinations available upon request

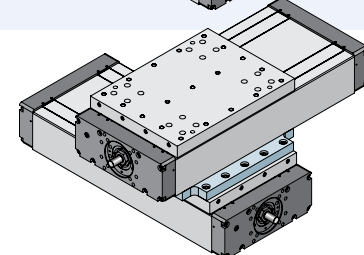

TRS225 C2B to TRS225

TRS Twin Rail Stage Actuator

TRS SUPPORT RECOMMENDATIONS

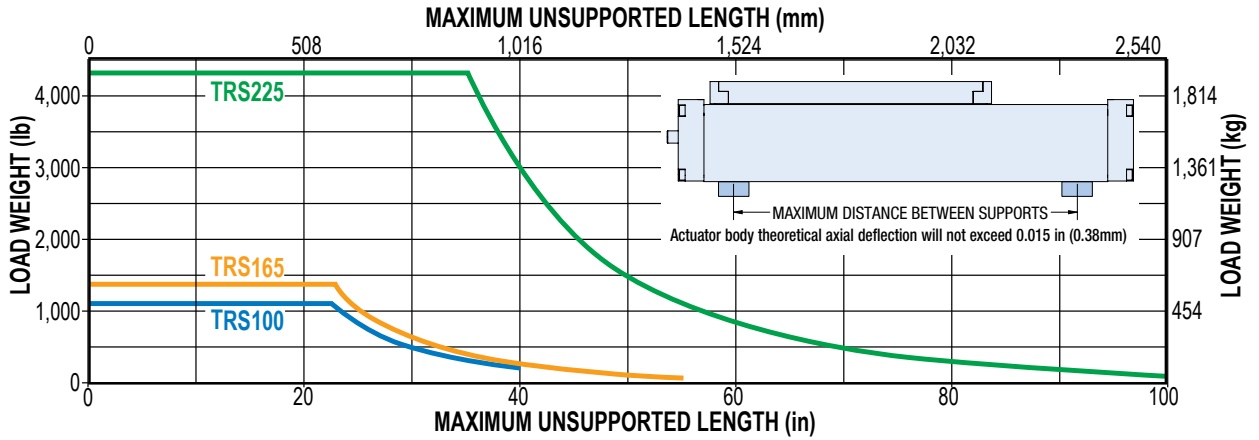

SCREW/NUT COMBINATIONS

TRS100, TRS165 BALL & ROLLER SCREW CRITICAL SPEED CAPACITIES

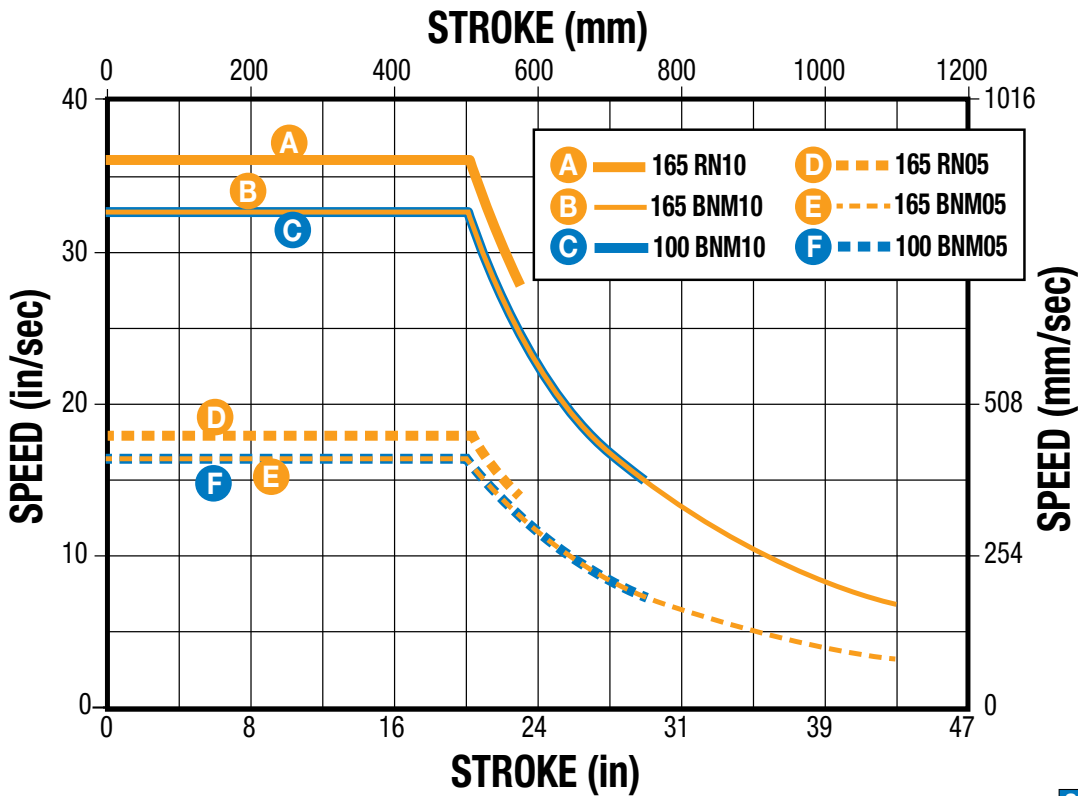

SCREW CODE	DESCRIPTION
BN	Ball Nut
BNM	Ball Nut Metric
RN	Roller Nut

TRS Twin Rail Stage Actuator



SCREW/NUT COMBINATIONS

SCREW LIFE CALCULATION TRS100, TRS165

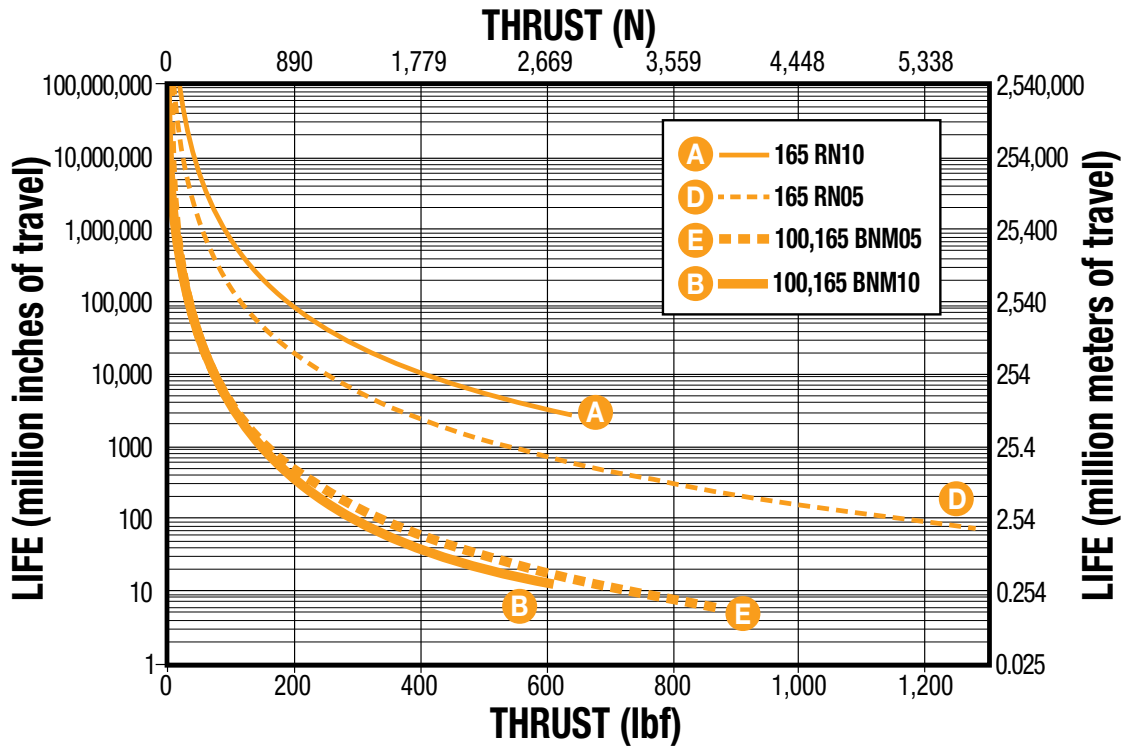

*Life indicates theoretical maximum life of screw only, under ideal conditions and does not indicate expected life of actuator.

TRS225 BALL & ROLLER SCREW CRITICAL SPEED CAPACITIES

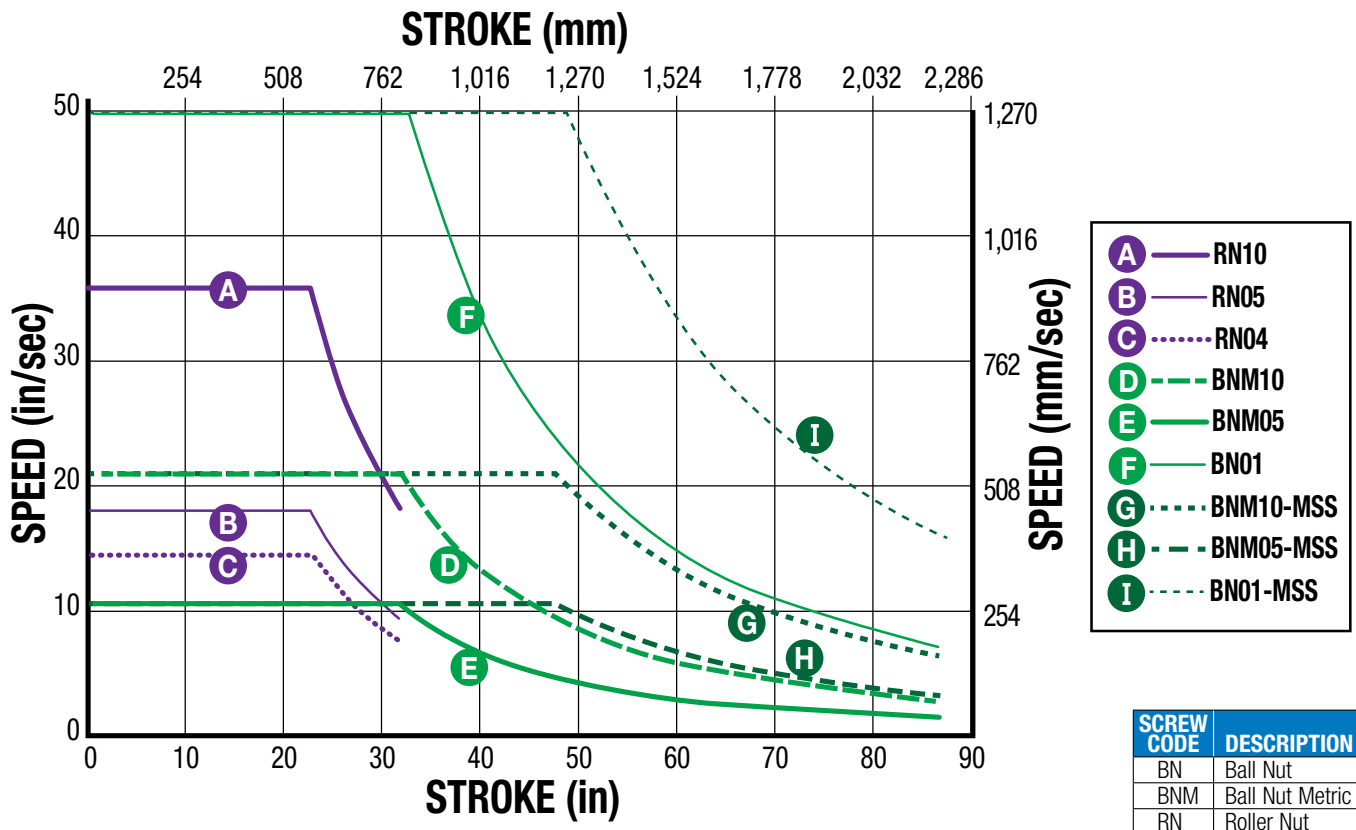

SCREW CODE	DESCRIPTION
BN	Ball Nut
BNM	Ball Nut Metric
RN	Roller Nut

TRS Twin Rail Stage Actuator

OPTION

MSS - MID SCREW SUPPORT OPTION

- Mid Screw Support (MSS) provides higher critical speed capabilities for all ball nut options at longer stroke lengths
 - Ball screw always supported in middle of actuator to decrease screw whip at higher rotational speeds
 - Works in all orientations (vertical, horizontal, and at an angle)
 - Maintenance free
 - Available for TRS 225 size for BN, BNM ball screws
- See TRS225 critical speed graph for MSS speed capabilities

 NOTE: MSS option adds 3.1 in (79 mm) to the overall length of the TRS225

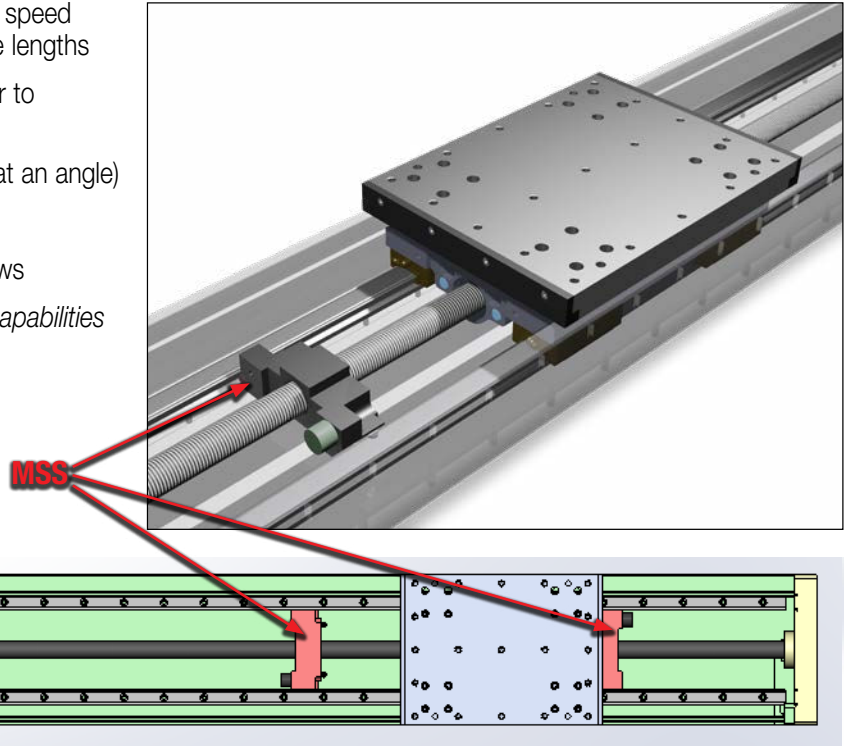

SCREW/NUT COMBINATIONS

SCREW LIFE CALCULATION TRS225

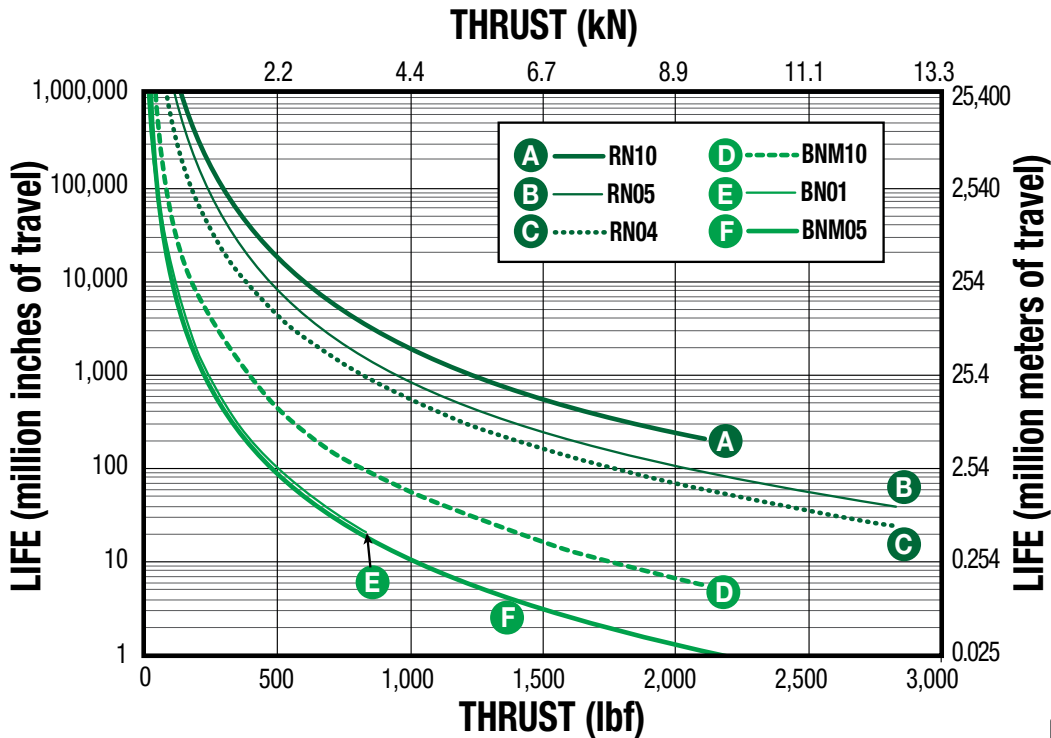

**Life indicates theoretical maximum life of screw only, under ideal conditions and does not indicate expected life of actuator.

SCREW CODE	DESCRIPTION
BN	Ball Nut
BNM	Ball Nut Metric
RN	Roller Nut

TRS Twin Rail Stage Actuator

TOLOMATIC.COM/CAD
DOWNLOAD 3D CAD
 ALWAYS USE CAD SOLID MODEL TO
 DETERMINE CRITICAL DIMENSIONS

DIMENSIONS, End View

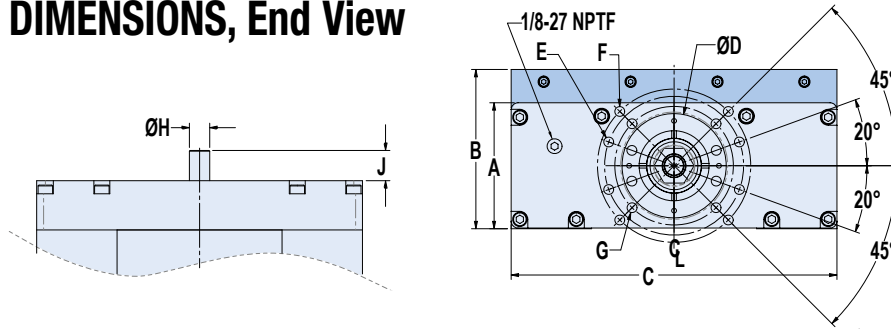

No Motor Mount (threaded holes and bolt circle; *when no motor mount is selected*)

Note: Tapped holes and purge ports are located on both ends of the TRS

	A	B	C	D	E	F	G	H	J
TRS100	67.0	81.8	100.0	42.05 / 42.00	M6x1.0 ∇ 13.0 (4) ON DIA 57.00 B.C.	M6x1.0 ∇ 12.0 (4) ON DIA 60.00 B.C.	—	10.000 / 9.975	9.0
TRS165	67.0	81.8	165.0	42.05 / 42.00	M6x1.0 ∇ 13.0 (4) ON DIA 57.00 B.C.	M6x1.0 ∇ 12.0 (4) ON DIA 60.00 B.C.	—	10.000 / 9.975	9.0
TRS225	87.0	110.0	225.0	72.05 / 72.00	M8x1.25 ∇ 18.0 (4) ON DIA 96.00 B.C.	M8x1.25 ∇ 18.0 (4) ON DIA 106.00 B.C.	M8x1.25 ∇ 18.0 (4) ON DIA 82.00 B.C.	14.000 / 13.975	20.9

Dimensions in millimeters

	A	B	C	D	E	F	G	H	J
TRS100	2.64	3.22	3.94	1.656 / 1.654	M6x1.0 ∇ 0.51 (4) ON DIA 2.244 B.C.	M6x1.0 ∇ 0.47 (4) ON DIA 2.362 B.C.	—	0.3937 / 0.3927	0.36
TRS165	2.64	3.22	6.50	1.656 / 1.654	M6x1.0 ∇ 0.51 (4) ON DIA 2.244 B.C.	M6x1.0 ∇ 0.47 (4) ON DIA 2.362 B.C.	—	0.3937 / 0.3927	0.36
TRS225	3.43	4.33	8.86	2.837 / 2.835	M8x1.25 ∇ 0.71 (4) ON DIA 3.780 B.C.	M8x1.25 ∇ 0.71 (4) ON DIA 4.173 B.C.	M8x1.25 ∇ 0.71 (4) ON DIA 3.228 B.C.	0.5512 / 0.5502	0.82

Dimensions in inches

DIMENSIONS, LMI & Bottom Views

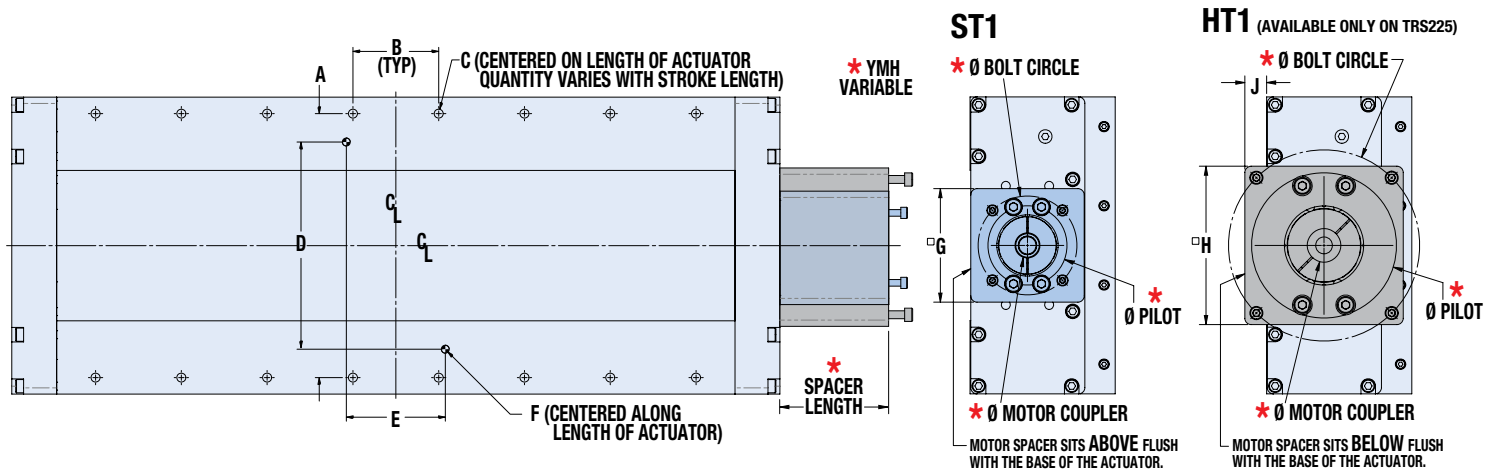

	A	B	C	D	E	F	G	H	J
TRS100	75.0	60.0	M8x1.25 ∇ 12.7	55.0	75.0	6.026 / 6.013 ∇ 12.0	70.0	-	-
TRS165	135.0	60.0	M8x1.25 ∇ 12.7	100.0	75.00	6.026 / 6.013 ∇ 12.0	70.0	-	-
TRS225	200.0	65.0	M8x1.25 ∇ 12.7	157.0	75.0	6.026 / 6.013 ∇ 12.0	86.0	120.0	16.5

Dimensions in millimeters

	A	B	C	D	E	F	G	H	J
TRS100	2.95	2.36	M8x1.25 ∇ 0.50	2.17	2.95	0.2372 / 0.2367 ∇ 0.47	2.76	-	-
TRS165	5.31	2.36	M8x1.25 ∇ 0.50	3.94	2.95	0.2372 / 0.2367 ∇ 0.47	2.76	-	-
TRS225	7.87	2.56	M8x1.25 ∇ 0.50	6.18	2.95	0.2372 / 0.2367 ∇ 0.47	3.39	4.72	.65

Dimensions in inches

TRS Twin Rail Stage Actuator

DIMENSIONS: RP Motor Mounts:

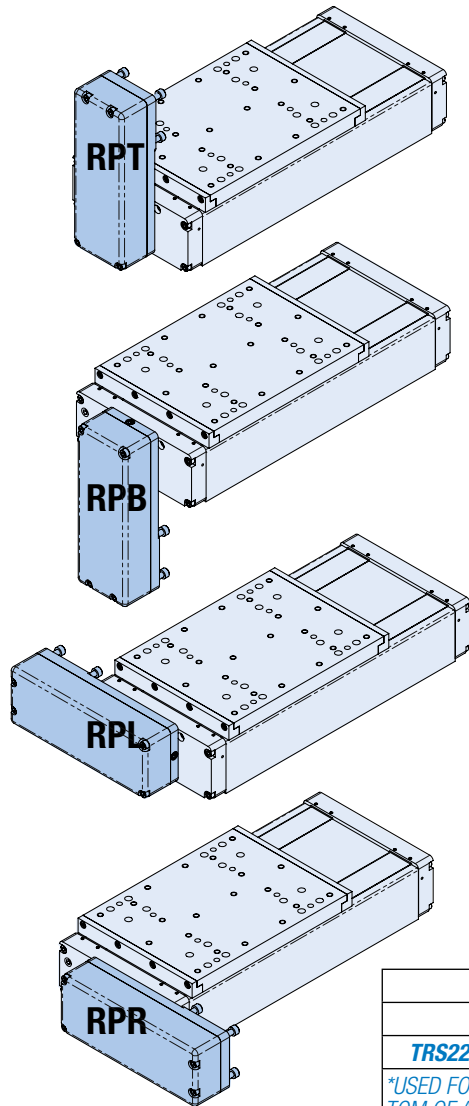

TOLOMATIC.COM/CAD
DOWNLOAD 3D CAD
 ALWAYS USE CAD SOLID MODEL TO
 DETERMINE CRITICAL DIMENSIONS

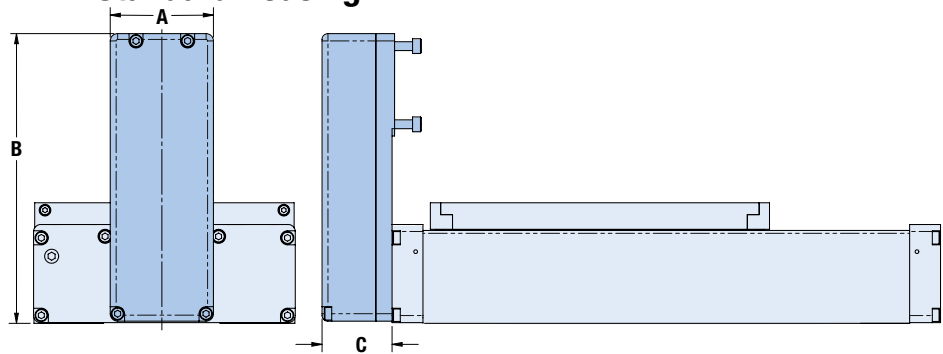

RP1 Standard Housing

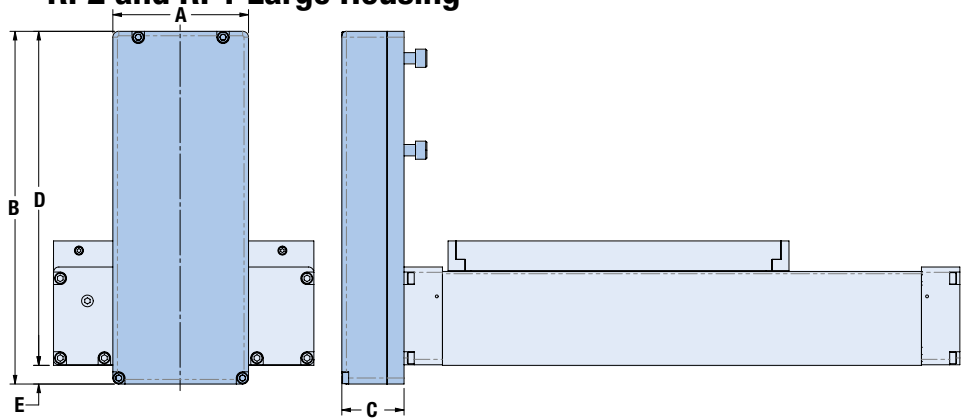

RP2 and RP1 Large Housing



	A	B	C	D	E	Dimensions in millimeters
TRS100	70.0	195.0	47.5	—	—	
TRS165	70.0	195.0	47.5	—	—	
TRS225 RP1 Small Housing*	86.0	260.0	55.0	—	—	
<i>*USED FOR MOTORS WITH FLANGES SMALLER THAN 86MM ON TRS225. STANDARD RP SITS ABOVE FLUSH WITH BOTTOM OF ACTUATOR.</i>						
TRS225 RP Large Housing**	120.0	312.0	55.0	295.5	16.5	
<i>**USED FOR MOTORS WITH FLANGES LARGE THAN 86MM ON RP_1, AND ALL MOTOR SIZES FOR RP_2. LARGE RP PROTRUDES BELOW FLUSH WITH BOTTOM OF THE ACTUATOR.</i>						

	A	B	C	D	E	Dimensions in inches
TRS100	2.76	7.68	1.87	—	—	
TRS165	2.76	7.68	1.87	—	—	
TRS225 RP_1 Small Housing*	3.39	10.24	2.17	—	—	
<i>*USED FOR MOTORS WITH FLANGES SMALLER THAN 86MM ON TRS225. STANDARD RP SITS ABOVE FLUSH WITH BOTTOM OF ACTUATOR.</i>						
TRS225 RP Large Housing**	4.72	12.28	2.17	11.63	.65	
<i>**USED FOR MOTORS WITH FLANGES LARGE THAN 86MM ON RP_1, AND ALL MOTOR SIZES FOR RP_2. LARGE RP PROTRUDES BELOW FLUSH WITH BOTTOM OF THE ACTUATOR.</i>						



***LARGE FRAME MOTORS AND SMALLER SIZE ACTUATORS: Cantilevered motors need to be supported, if subjected to continuous rapid reversing duty and/or under dynamic conditions.**

TRS Twin Rail Stage Actuator

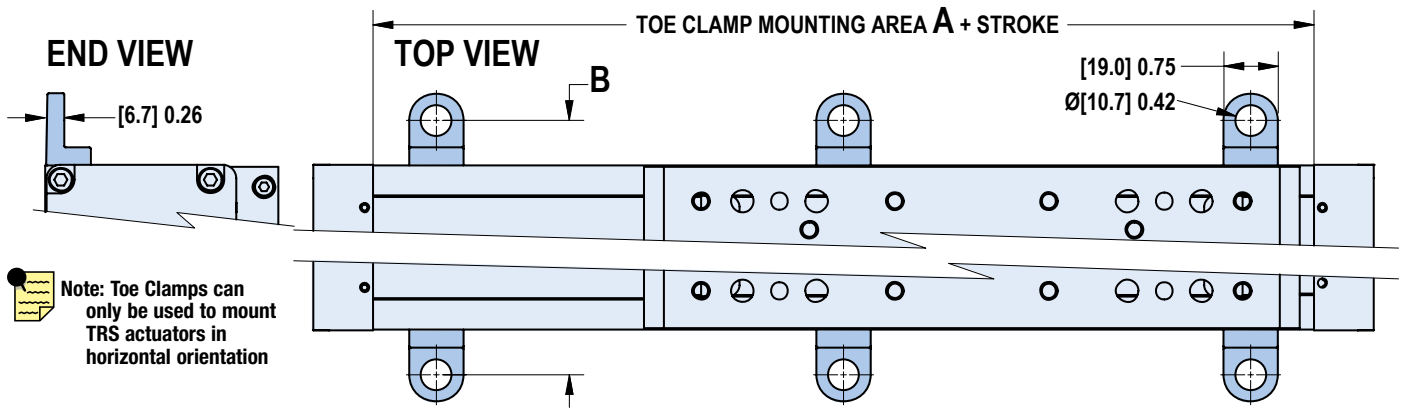

TOLOMATIC.COM/CAD
 DOWNLOAD 3D CAD
 ALWAYS USE CAD SOLID MODEL TO
 DETERMINE CRITICAL DIMENSIONS

DIMENSIONS: Toe Clamps



Note: Toe Clamps can only be used to mount TRS actuators in horizontal orientation

	A	B	C	D
TRS100	230.0	131.7	48.6	250.0
TRS165	240.0	196.7	48.6	260.0
TRS225	314.0	256.7	61.0	334.0

Dimensions in millimeters

	A	B	C	D
TRS100	9.06	5.19	1.91	9.84
TRS165	9.45	7.74	1.91	10.24
TRS225	13.36	10.10	2.40	13.15

Dimensions in inches

DIMENSIONS: Switch Rail

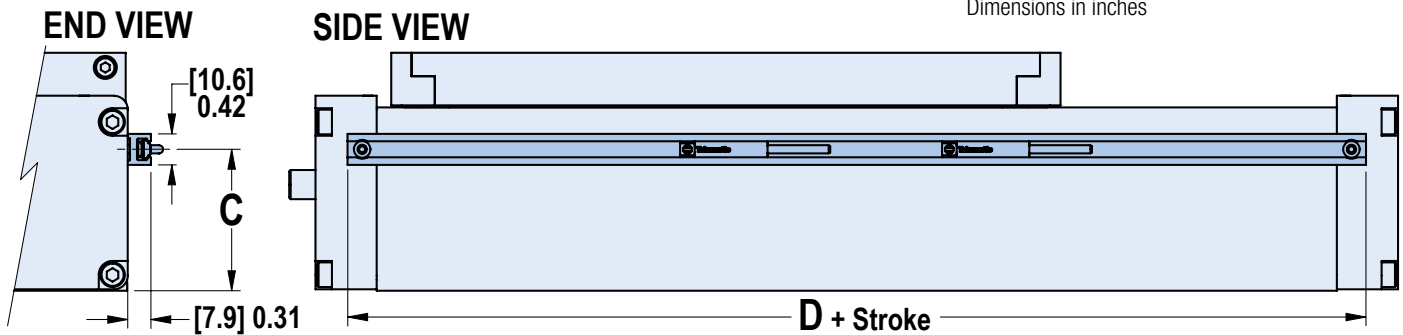

Note: Switch rail is installed on the right side of the actuator (from the motor end) for all motor mounting configurations except RPR1 where it is installed on the left side of the actuator.

TRS Twin Rail Stage Actuator

SWITCHES

SPECIFICATIONS









TRS products offer a wide range of sensing choices. There are 12 switch choices: reed, solid state PNP (sourcing) or solid state NPN (sinking); in normally open or normally closed; with flying leads or quick-disconnect.

Commonly used for end-of-stroke positioning, these switches allow drop-in installation anywhere along the rail on the side of the actuator. The one-piece design includes the retained fastening hardware.

Switches are used to send digital signals to PLC (programmable logic controller), TTL, CMOS circuit or other controller device. Switches contain reverse polarity protection. Solid state QD cables are shielded; shield should be terminated at flying lead end.

All switches are CE rated and are RoHS compliant. Switches feature bright red or yellow LED signal indicators; solid state switches also have green LED power indicators.



	Order Code	Lead	Switching Logic	Power LED	Signal LED	Operating Voltage	**Power Rating (Watts)	Switching Current (mA max.)	Current Consumption	Voltage Drop	Leakage Current	Temp. Range	Shock / Vibration
REED	R Y	5m	SPST Normally Open	—	Red	5 - 240 AC/DC	**10.0	100mA	—	3.0 V max.	—	14 to 158°F [-10 to 70°C]	50 G / 9 G
	R K	QD*											
	N Y	5m	SPST Normally Closed	—	Yellow	5 - 110 AC/DC							
	N K	QD*											
SOLID STATE	T Y	5m	PNP (Sourcing) Normally Open	Green	Yellow	10 - 30 VDC	**3.0	100mA	20 mA @ 24V	2.0 V max.	0.05 mA max.		
	T K	QD*											
	K Y	5m	NPN (Sinking) Normally Open	Green	Red								
	K K	QD*											
	P Y	5m	PNP (Sourcing) Normally Closed	Green	Yellow								
	P K	QD*											
	H Y	5m	NPN (Sinking) Normally Closed	Green	Red								
	H K	QD*											

*QD = Quick-disconnect Enclosure classification IEC 529 IP67 (NEMA 6) CABLES: Robotic grade, oil resistant polyurethane jacket, PVC insulation

⚠️**WARNING: Do not exceed power rating (Watt = Voltage x Amperage). Permanent damage to sensor will occur.

TRS Twin Rail Stage Actuator

WIRING DIAGRAMS

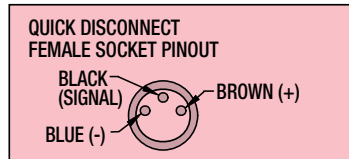
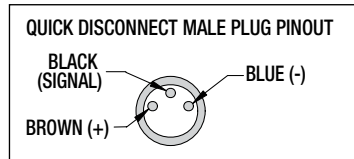
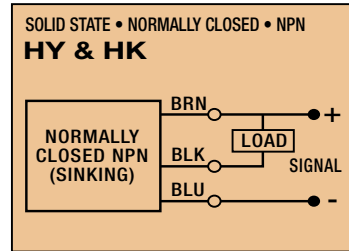
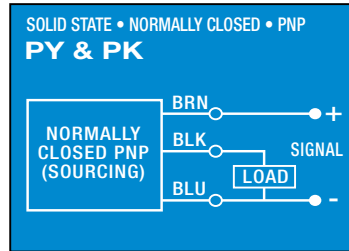
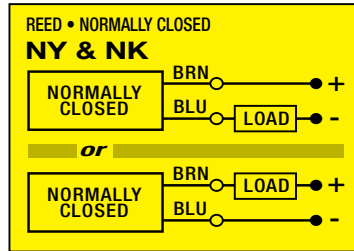
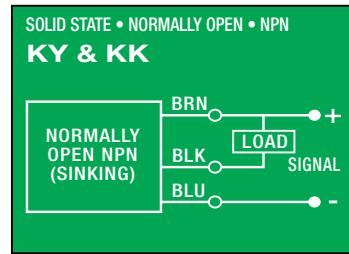
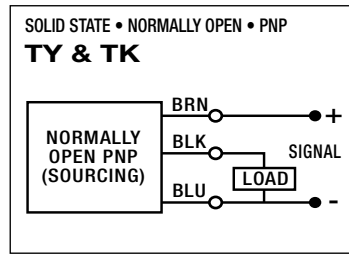
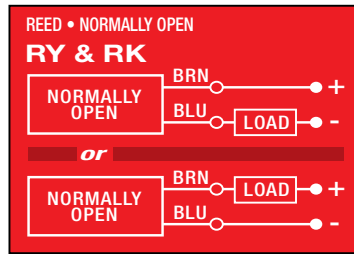

SWITCH INSTALLATION AND REPLACEMENT

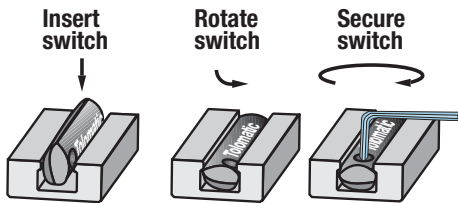

Place switch in side groove on tube at desired location with "Tolomatic" facing outward. While applying light pressure to the switch, rotate the switch halfway into the groove. Maintaining light pressure, rotate the switch in the opposite direction until it is fully inside the groove with "Tolomatic" visible. Re-position the switch to the exact location and lock the switch securely into place by tightening the screw on the switch.

SWITCH DIMENSIONS

- direct connect

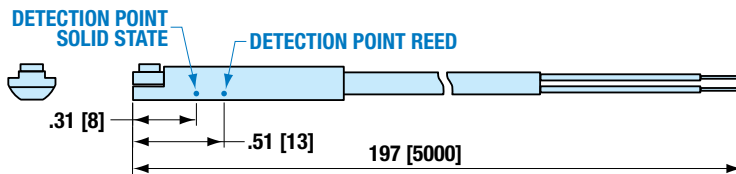

- QD (Quick-disconnect) switch

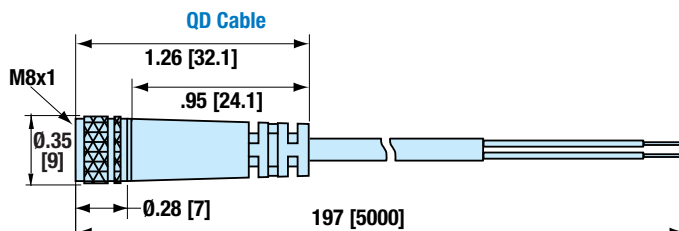
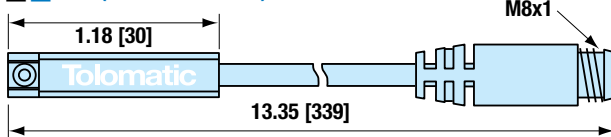

Dimensions in inches [brackets indicate dimensions in millimeters]

See Page 14 for Switch Rail Dimensions

COMPILE APPLICATION REQUIREMENTS

ORIENTATION

Horizontal Side Horizontal Down Vertical

Load attached to carrier OR Load supported by other mechanism

APPLICATION DATA WORKSHEET

Fill in known data. Not all information is required for all applications

Angled ° α _____ β _____

DISTANCE FROM CENTER OF CARRIER TO LOAD CENTER OF GRAVITY

d_x _____
 d_y _____
 d_z _____

inch (U.S. Standard) millimeter (Metric)

STROKE LENGTH

inch (S I) (U.S. Standard) millimeters (S M) (Metric)

NOTE: If load or force on carrier changes during cycle use the highest numbers for calculations

LOAD

lb. (U.S. Standard) kg. (Metric)

THRUST REQUIRED

lbf. (U.S. Standard) N (Metric)

F_z _____
 F_y _____

BENDING MOMENTS APPLIED TO CARRIER

in.-lbs. (U.S. Standard) N-m (Metric)

PRECISION

Repeatability _____
 inch millimeters

OPERATING ENVIRONMENT

Temperature, Contamination, etc.

MOVE PROFILE

Move Distance _____
 inch millimeters
 Dwell Time After Move _____
 Max. Speed _____
 in/sec mm/sec

MOVE TIME

sec

NO. OF CYCLES

per minute per hour

SCREW DRIVE

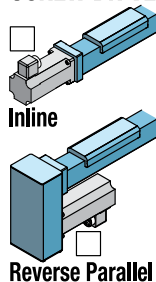

MOTION PROFILE

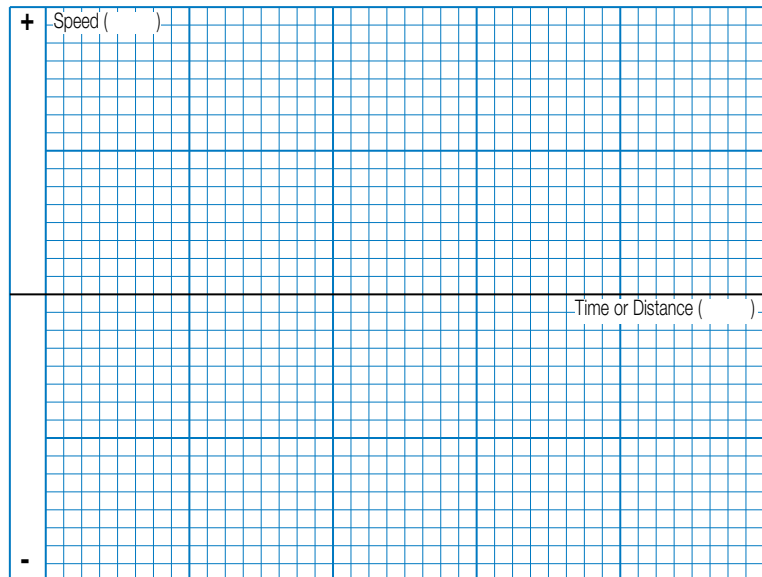

Graph your most demanding cycle, including accel/decel, velocity and dwell times. You may also want to indicate load variations and I/O changes during the cycle. Label axes with proper scale and units.

USE THE TOLONATIC SIZING AND SELECTION SOFTWARE AVAILABLE ON-LINE AT www.tolomatic.com OR... CALL TOLONATIC AT 1-800-328-2174.

We will provide any assistance needed to determine the proper actuator for the job.

FAX 1-763-478-8080

EMAIL help@tolomatic.com

CONTACT INFORMATION

Name, Phone, Email
Co. Name, Etc.

SELECTION GUIDELINES

The process of selecting a load bearing actuator for a given application can be complex. It is highly recommended that you contact Tolomatic or a Tolomatic Distributor for assistance in selecting the best actuator for your application. The following overview of the selection guidelines are for educational purposes only. The Tolomatic Sizelt Software is also available on Tolomatic.com

1 CHOOSE ACTUATOR SIZE

Choose an actuator that has the thrust, speed and moment load capacity to move the load. Use the Critical Speed graph (page TRS_9) for the screw and the Moment and Load Capacity table (pg. TRS_6) for the actuator.

2 COMPARE LOAD TO MAXIMUM LOAD CAPACITIES

Calculate the application load (combination of load mass and forces applied to the carrier) and application bending moments (sum of all moments M_x , M_y , and M_z applied to the carrier). Be sure to evaluate the magnitude of dynamic inertia moments. When a rigidly attached load mass is accelerated or decelerated, its inertia induces bending moments on the carrier. Careful attention to how the load is decelerated at

the end of the stroke is required for extended actuator performance and application safety. If either load or any of your moments exceed figures indicated in the Moment and Load Capacity table (pg. TRS_6) for the actuator consider:

- 1) Higher capacity bearing style
- 2) A larger actuator size
- 4) External guide system

3 CALCULATE LOAD FACTOR LF

For loads with a center of gravity offset from the carrier account for both applied (static) and dynamic loads. The load factor (LF) must not exceed the value of 1.0

$$L_f = \frac{M_x}{M_{x_{max}}} + \frac{M_y}{M_{y_{max}}} + \frac{M_z}{M_{z_{max}}} + \frac{F_y}{F_{y_{max}}} + \frac{F_z}{F_{z_{max}}} \leq 1.0$$

If L_f exceeds the value of 1.0, consider the four choices listed in step #2.

4 ESTABLISH YOUR MOTION PROFILE AND CALCULATE ACCELERATION RATE

Using the application stroke length and maximum carrier velocity (or time to complete the linear motion), establish the motion profile. Select either triangular (accel-decel) or trapezoidal (accel-constant speed-decel) profile. Now calculate the maximum acceleration and deceleration rates of the move. A TRS twin rail screw-driven actuator speed should not exceed the value in the critical speed capacity graph (page TRS_9) for the screw/nut combination chosen. Also, do not exceed safe rates of dynamic inertia moments determined in step #3.

5 SELECT THE LEAD SCREW

Based on the application requirements for accuracy,

backlash, quiet operation, life, etc. select the appropriate screw type (ball screw or roller screw) and the pitch (lead). For additional information on screw selection, consult "Selecting the Optimal Screw Technology" (#9900-4644) available at www.tolomatic.com.

6 SELECT MOTOR AND DRIVE

To help select a motor and drive, leverage the Tolomatic Sizelt software, available on Tolomatic.com to calculate the application thrust and torque requirements.

7 CONSIDER OPTIONS

- TC_ Toe clamps
- C2C Carrier-to-carrier mounting
- Switches - Reed, Solid State PNP or NPN, all available normally open or normally closed

SPEED FACTOR

FOR APPLICATIONS WITH HIGH SPEED OR SIGNIFICANT SHOCK AND VIBRATION: Loads and bending moments must be multiplied by speed factor from the graph below to obtain full rated life of profiled rail bearing system.

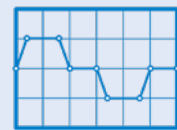
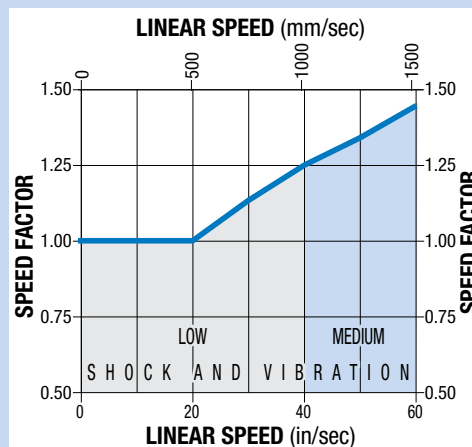

sizeit.tolomatic.com
for fast, accurate
actuator selection

Use Tolomatic Sizing Software to determine available options and accessories based on your application requirements.

TRS Twin Rail Stage Actuator

ORDERING

BASE MODEL SPECIFICATIONS

TRS 100 BNO5 SM200.50 RPL1

OPTIONS SPECIFICATIONS

TC6 C2C RY1 RK2 YM_x_x_x_x_x_x

MODEL
TRS Twin Rail Stage

SIZE
100 165 or 225

NUT/SCREW CONFIGURATION

Code	Description	TRS100	TRS165	TRS225
BNO5	Ball Nut, 5 mm lead	Yes	Yes	Yes
BNO10	Ball Nut, 10 mm lead	Yes	Yes	Yes
BNO1	Ball Nut, 1 in lead	–	Yes	–
RNO4	Roller Nut, 4 mm lead	–	Yes	–
RNO5	Roller Nut, 5 mm lead	Yes	Yes	Yes
RNO10	Roller Nut, 10 mm lead	Yes	Yes	Yes

STROKE LENGTH

SM Stroke, then enter desired stroke length in millimeters

	MAX. STROKE	
TRS100	750	29.5
TRS165	1,100	43.3
TRS 225	2,200	87.0
	mm	in

MODEL
ST1 Standard TRS actuator
HT1 High Torque Option

MOTOR MOUNTING / REDUCTIONS

The length on the leadscrew and coupling device is determined by motor selection. Motor type and frame size must be specified when ordering.

(must choose one)

LMI In-Line mount
RPL1 1:1 Reverse-Parallel mount left
RPR1 1:1 Reverse-Parallel mount right
RPB1 1:1 Reverse-Parallel mount bottom
RPT1 1:1 Reverse-Parallel mount top
RPL2 2:1 Reverse-Parallel mount left
RPR2 2:1 Reverse-Parallel mount right
RPB2 2:1 Reverse-Parallel mount bottom
RPT2 2:1 Reverse-Parallel mount top

BASE MOUNTING
Blank Standard bottom threaded holes, no Toe clamp mounting slots
TC_x Toe clamps + mounting slots*
*x = number of toe clamps

CARRIER MOUNTING
Blank Standard Carrier
C2C Carrier-to-carrier mounting**
**Only available for 100 & 225 sizes
C2B Carrier-to-base mounting†
†Only available with 225 size

⚠ Due to the complexity of the moment loads in a carrier to carrier system, Tolomatic recommends working with a Tolomatic representative to size the system

MID SCREW SUPPORT
MSS Support for high speeds and long stroke length§
§Only available for TRS225 w/ball screw

SWITCHES

RY_ Reed Switch (Normally Open) with 5-meter lead, & enter quantity desired
RK_ Reed Switch (Normally Open) with 5-meter lead/QD, & quantity
NY_ Reed Switch (Normally Closed) with 5-meter lead, & quantity
NK_ Reed Switch (Normally Closed) with 5-meter lead/QD, & quantity
TY_ Solid State Switch PNP (Normally Open) with 5-meter lead, & quantity
TK_ Solid State Switch PNP (Normally Open) with 5-meter lead/QD, & quantity
KY_ Solid State Switch NPN (Normally Open) with 5-meter lead, & quantity
KK_ Solid State Switch NPN (Normally Open) with 5-meter lead/QD, & quantity
PY_ Solid State Switch PNP (Normally Closed) with 5-meter lead, & quantity
PK_ Solid State Switch PNP (Normally Closed) with 5-meter lead/QD, & quantity
HY_ Solid State Switch NPN (Normally Closed) with 5-meter lead, & quantity
HK_ Solid State Switch NPN (Normally Closed) with 5-meter lead/QD, & quantity
Note: QD = Quick Disconnect

MOTOR
YM_ Your Motor Here

⚠ Not all codes listed are compatible with all options.



tolomatic.com/yhm
YOUR MOTOR HERE
Motor Mounts
Made-to-Order



sizeit.tolomatic.com
for fast, accurate
actuator selection



tolomatic.com/ask
Technical support
before and after
purchase

NOTE: Brakes mounted on reverse parallel motor mounts (especially in vertically positioned actuators) will not prevent back driving of the screw and the load falling under gravity in the event of a timing belt failure. An inline motor mount with a fail-safe brake mounted directly to the actuator shaft or a special geared or thru-shaft reverse parallel construction should be considered if a brake is required in a safety critical application. Contact Tolomatic for alternate reverse parallel brake mounting options.

Gearheads may be used with reverse parallel motor mounts. However, the torque on the belt and internal RP components must remain below the capabilities of the assembly to prevent belt slipping or premature failure. Contact Tolomatic for additional information if required.

FIELD RETROFIT

Dust Band Repair Kit	RK then Model & Stroke in millimeters DB
Example:	RK TRS 100 SM200.50 DB

The Tolomatic Difference Expect More From the Industry Leader:



INNOVATIVE PRODUCTS

Solutions with Endurance TechnologySM for challenging applications.



FAST DELIVERY

Built-to-order with configurable stroke lengths and flexible mounting options.

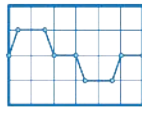

ACTUATOR SIZING

Size and select electric actuators with our online software.



YOUR MOTOR HERE[®]

Match your motor to compatible mounting plates with Tolomatic actuators.



CAD LIBRARY

Download 2D or 3D CAD files for Tolomatic products.



TECHNICAL SUPPORT

Get a question answered or request a virtual design consultation with one of our engineers.

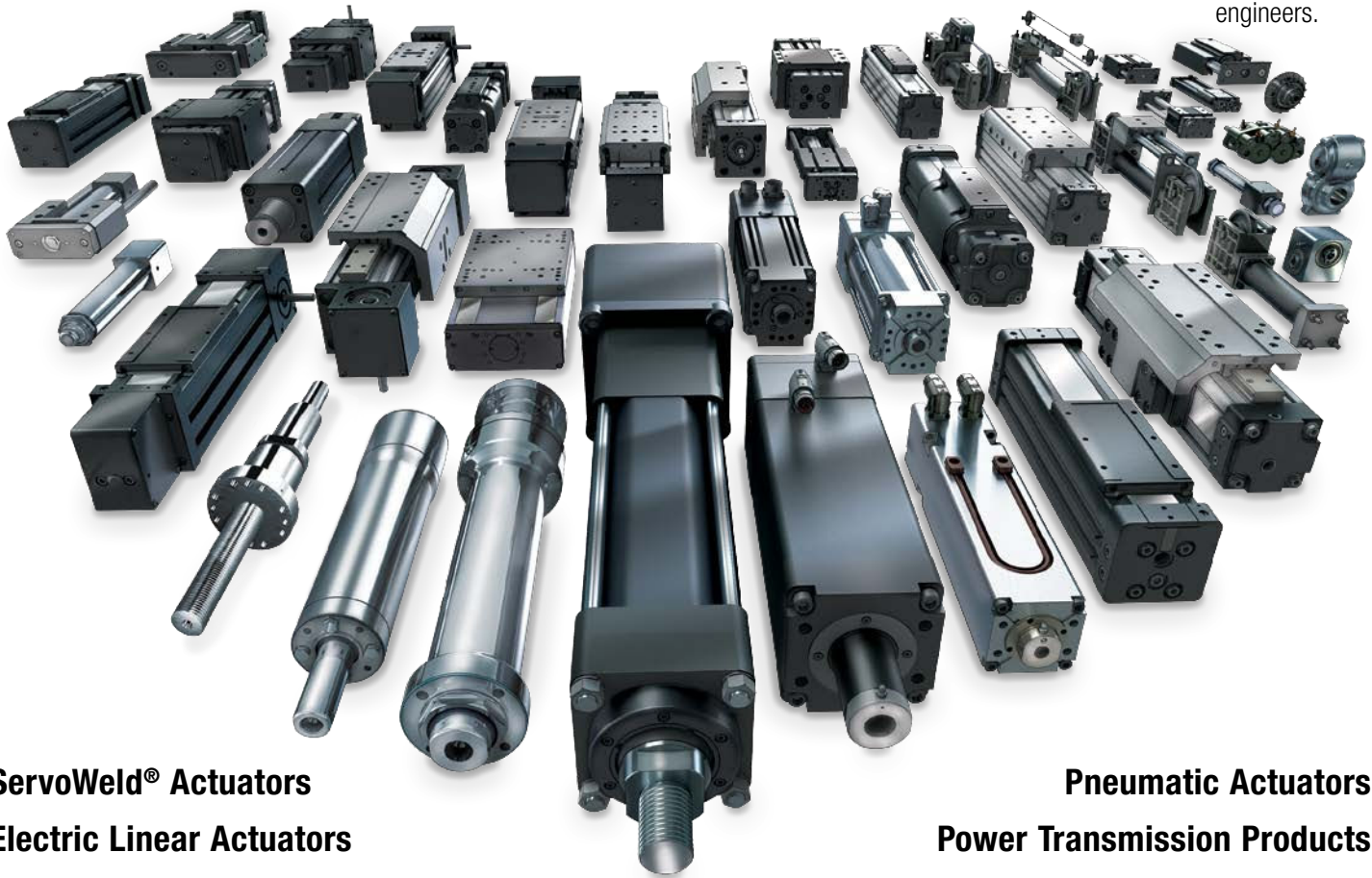

ServoWeld[®] Actuators
Electric Linear Actuators

Pneumatic Actuators
Power Transmission Products



MADE IN U.S.A.

Tolomatic[™]
EXCELLENCE IN MOTION

COMPANY WITH
QUALITY SYSTEM
CERTIFIED BY DNV
= ISO 9001 =
Certified site: Hamel, MN

USA - Headquarters

Tolomatic Inc.
3800 County Road 116
Hamel, MN 55340, USA
Phone: (763) 478-8000
Toll-Free: **1-800-328-2174**
sales@tolomatic.com
www.tolomatic.com

MEXICO

Centro de Servicio
Parque Tecnológico Innovación
Int. 23, Lateral Estatal 431,
Santiago de Querétaro,
El Marqués, México, C.P. 76246
Phone: +1 (763) 478-8000
help@tolomatic.com

EUROPE

Tolomatic Europe GmbH
Elisabethenstr. 20
65428 Rüsselsheim
Germany
Phone: +49 6142 17604-0
help@tolomatic.eu
www.tolomatic.com/de-de

CHINA

Tolomatic Automation Products (Suzhou) Co. Ltd.
No. 60 Chuangye Street, Building 2
Huqiu District, SND Suzhou
Jiangsu 215011 - P.R. China
Phone: +86 (512) 6750-8506
Tolomatic_China@tolomatic.com

All brand and product names are trademarks or registered trademarks of their respective owners. Information in this document is believed accurate at time of printing. However, Tolomatic assumes no responsibility for its use or for any errors

that may appear in this document. Tolomatic reserves the right to change the design or operation of the equipment described herein and any associated motion products without notice. Information in this document is subject to change without notice.

Visit www.tolomatic.com for the most up-to-date technical information