

MXB RODLESS BELT DRIVE ACTUATORS

ENDURANCE TECHNOLOGYSM

A Tolomatic Design PrincipleSM

U UNGUIDED

S SOLID BEARING

P PROFILED RAIL



LINEAR SOLUTIONS MADE EASY

MXB Rodless Belt Drive Actuators





DESIGNED TO OUTLAST EVERY BELT DRIVE ACTUATOR ON THE MARKET



The MXB belt drive electric actuator is exactly what you would expect from the industry's number one rodless supplier. Designed with our exclusive **ENDURANCE TECHNOLOGY™** features, the MXB delivers superior performance to meet the most demanding applications. Nobody knows rodless like Tolomatic, and the MXB proves it.

- MXB-**U**, MXB-**S** & MXB-**P**: Low profile to fit your application
- MXB-**S**: Engineered bearing material in trapezoidal shape for less wear, low static & dynamic friction
- MXB-**P**: High precision bearings feature smooth, low breakaway motion
- MXB-**P**: Durable profiled rail design uses recirculating ball technology to reduce friction and extend actuator life.
- MXB-**P**: High load and bending moment capacities

A Comparison of Belt Drive Actuators

	B3W	MXB-U	MXB-S	MXB-P
				
Features:	High load and bending moment capacities	Basic thrust, requires external guidance and support	Medium load and bending moment capacities	High load and bending moment capacities
Load up to: <i>(with options)</i>	35.6 kN [8,000 lbf]	NA	4.6 kN [1,040 lbf]	11.5 kN [2,584 lbf]
Thrust up to:	1.4 kN [325 lbf]	1.9 kN [418 lbf]	1.9 kN [418 lbf]	1.9 kN [418 lbf]
Speed up to:	5.1 m/sec [200 in/sec]	5.1 m/sec [200 in/sec]	2.5 m/sec [100 in/sec]	3.9 m/sec [150 in/sec]
Stroke Length up to:	14.6 m [574 in]	10.5 m [414 in]	10.5 m [414 in]	10.5 m [414 in]
www.tolomatic.com for complete information, search by literature number:				
Literature Number:	3600-4176	8500-4000	8500-4000	8500-4000

(Not all models deliver ALL maximum values listed, i.e.: Maximum thrust may not be available with maximum speed)

MXB Rodless Belt Drive Actuators

APPLICATIONS

X-Y Multi-Axis

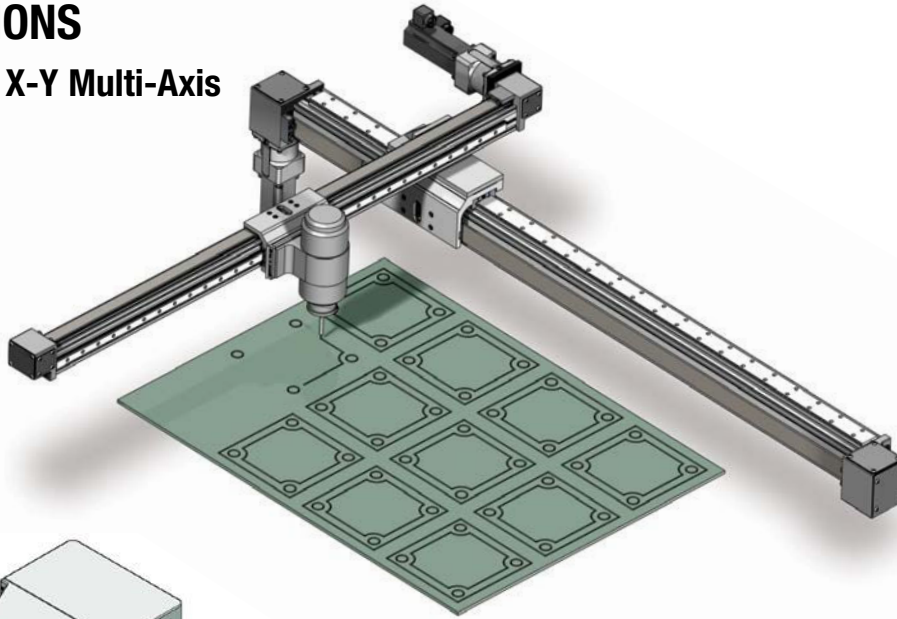

Workcenter Positioning

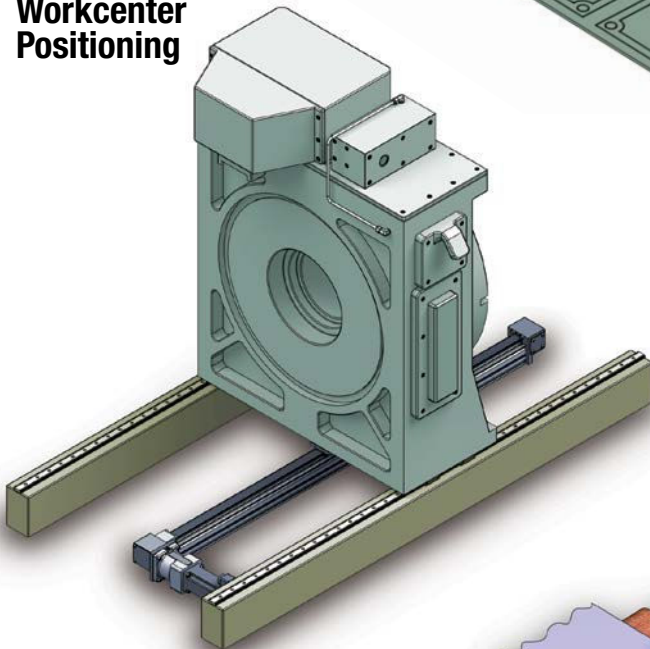

High Speed Flying Cut Off

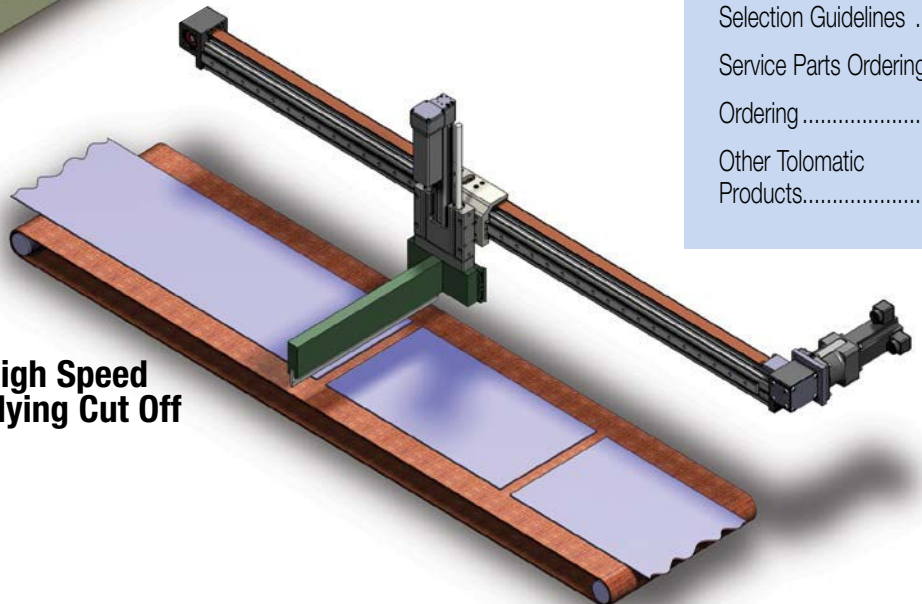

- Adhesive dispensing
- Aligning
- Animation
- Assembly
- Automotive
- Camera positioning
- Conveyors
- Cutting
- Diverters
- Inspection
- Laser marking
- Material cutting
- Milling
- Packaging equipment
- Parts transfer
- Pick & place
- Positioning
- Product handling
- Pulp & Paper
- Slitting
- Sorting
- Spraying
- Stacking
- Table positioning
- Test stations
- Wire winding

CONTENTS

MXB Belt Drive Actuator... 2

Applications..... 3

MXB-U Features..... 4

MXB-S Features 6

MXB-P Features 8

Specifications 10

MXB-U Actuator and Options Dimensions 17

MXB-S Actuator Dimensions..... 18

MXB-S Option Dimensions..... 19

MXB-P Actuator Dimensions..... 20

MXB-P Option Dimensions..... 21

Motor Mounting 22

Switches 24

Application Data Worksheet 26

Selection Guidelines 27

Service Parts Ordering... 28

Ordering 29

Other Tolomatic Products..... 30

MXB-**U** UNGUIDED BELT-DRIVE ACTUATOR

ENDURANCE TECHNOLOGYSM

A Tolomatic Design Principle

Endurance TechnologySM features are designed for maximum durability to provide extended service life.

The MXB-U rodless actuator is a pre-assembled compact linear belt solution for use in applications with existing guides & supports. This economical actuator features speeds up to 5080 mm/sec (200 in/sec) and thrusts up to 1859 N (418 lbf). Built-to-order in stroke lengths up to 10,500 mm (414 in).

MOTOR ORIENTATION

YOU CAN CHOOSE:

- Direct drive option directly couples motor to the drive shaft; one-piece housing construction for optimum alignment and support of the motor
- Reduction option in 3:1 reduction (2:1 on MXB16)

DURABLE BELT MATERIAL

High power polyurethane HTD tooth profile belt with steel tensile members resists stretching

YOUR MOTOR HERE

YOU CAN CHOOSE:

- Specify the device to be installed and actuator ships with proper mounting hardware
- Specify and ship your device to Tolomatic for factory installation
- Motor supplied and installed by Tolomatic

OVERSIZED PULLEY BEARINGS

Drive shaft assembly incorporates oversized shielded/sealed ball bearings for long life and high speeds

STEEL REINFORCED/HTD BELT PROFILE

- Belt of polyurethane material reinforced with steel tension members to produce high carrier thrusts without belt stretch.
- HTD tooth profile distributes tooth load more evenly and provides greater tooth shear strength, allowing for higher thrust loading.
- The deep teeth of the HTD profile are cogging-resistant, preventing potentially damaging positioning errors.

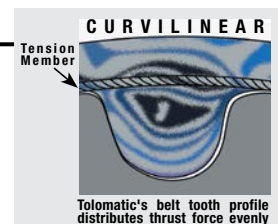

Tolomatic... MAXIMUM DURABILITY

EXCELLENCE IN MOTION

INCH OR METRIC MOUNTING

Your choice of blank, inch (US standard) or metric mounting to the plate

LOW PLATE HEIGHT

Reduces overall actuator envelope

EXTERNAL BUMPERS

Polyurethane bumpers protect the belt and clamp assembly from damage at end-of-stroke

BELT TENSIONING SYSTEM

The open slot on the guide plate permits easy access to the belt tensioning screw. No disassembly required

LIGHTWEIGHT ALUMINUM DESIGN

Clear anodized extrusion design is optimized for rigidity and strength

NOTE: Boxed letters indicate ordering codes

OPTIONS



MOUNTING PLATES **M****P**

- Provides clearance for motor and mount
- 16,25,32 sizes attach with T-Nuts
- 40,50,63 sizes attach with Tube Clamps



HEAD COVER PLATE **H****C****2**

- Provides protection for pulley and bearing



TUBE CLAMPS **T****C**

- Used for intermediate support
- Flush with bottom of actuator to retain low profile
- Drop-in, adjustable mounting locations (Not available on the MXB16U)



SWITCHES

- Wide variety of sensing choices: Reed, Solid State PNP or NPN, available normally open or normally closed
- Flush mount, drop-in installation
- Bright LEDs, power & signal indication
- CE rated, RoHS compliant

MXB-S SOLID BEARING BELT-DRIVE

ENDURANCE TECHNOLOGYSM

A Tolomatic Design Principle

Endurance TechnologySM features are designed for maximum durability to provide extended service life.

The MXB-S rodless style actuator is a compact linear belt solution for use in applications requiring light to moderate load carrying and guidance. The MXB-S actuator utilizes two field replaceable solid bearings that optimize stress distribution for optimal performance, rigidity and life. This economical actuator features speeds up to 2540 mm/sec (100 in/sec) and thrusts up to 1859 N (418 lbf). Built-to-order in stroke lengths up to 10,500 mm (414 in).

LARGE FLEXIBLE MOUNTING PATTERN

- Carrier gives more load stability
- Directly compatible with existing BCS & BC2 applications
- More fastening options

BELT TENSIONING SYSTEM

The open slot on the guide plate permits easy access to the belt tensioning screw. No disassembly required

EXTERNAL BUMPERS

Polyurethane bumpers protect the belt and clamp assembly from damage at end-of-stroke

TRAPEZOIDAL BEARINGS

- Trapezoidal design maximizes bearing surface area for less pressure on bearing surfaces; less pressure results in less wear
- Engineered bearing material has low static and dynamic friction with low wear properties for long lasting, smooth operation
- Bearings are field replaceable for extended service life

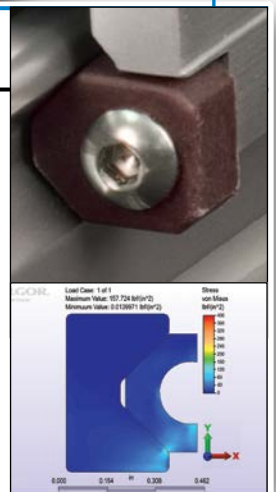

OVERSIZED PULLEY BEARINGS

Drive shaft assembly incorporates oversized shielded/sealed ball bearings for long life and high speeds

DURABLE BELT MATERIAL

High power polyurethane HTD tooth profile belt with steel tensile members resists stretching

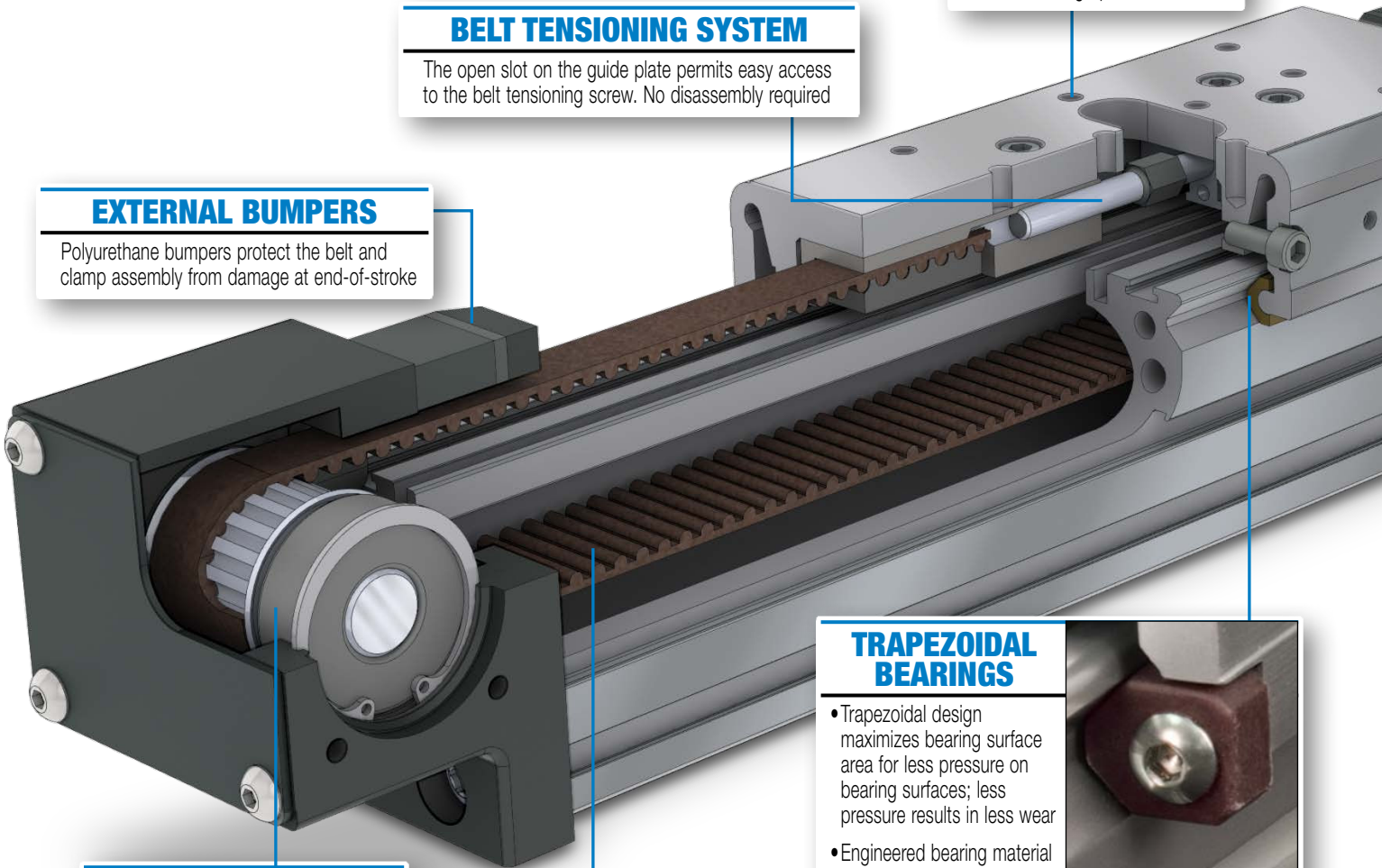

INCH OR METRIC MOUNTING

Your choice of blank, inch (US standard) or metric mounting to the plate

MOTOR ORIENTATION

YOU CAN CHOOSE:

- Direct drive option directly couples motor to the drive shaft; one-piece housing construction for optimum alignment and support of the motor
- Reduction option in 3:1 reduction (2:1 on MXB16)

YOUR MOTOR HERE

YOU CAN CHOOSE:

- Specify the device to be installed and actuator ships with proper mounting hardware
- Specify and ship your device to Tolomatic for factory installation
- Motor supplied and installed by Tolomatic

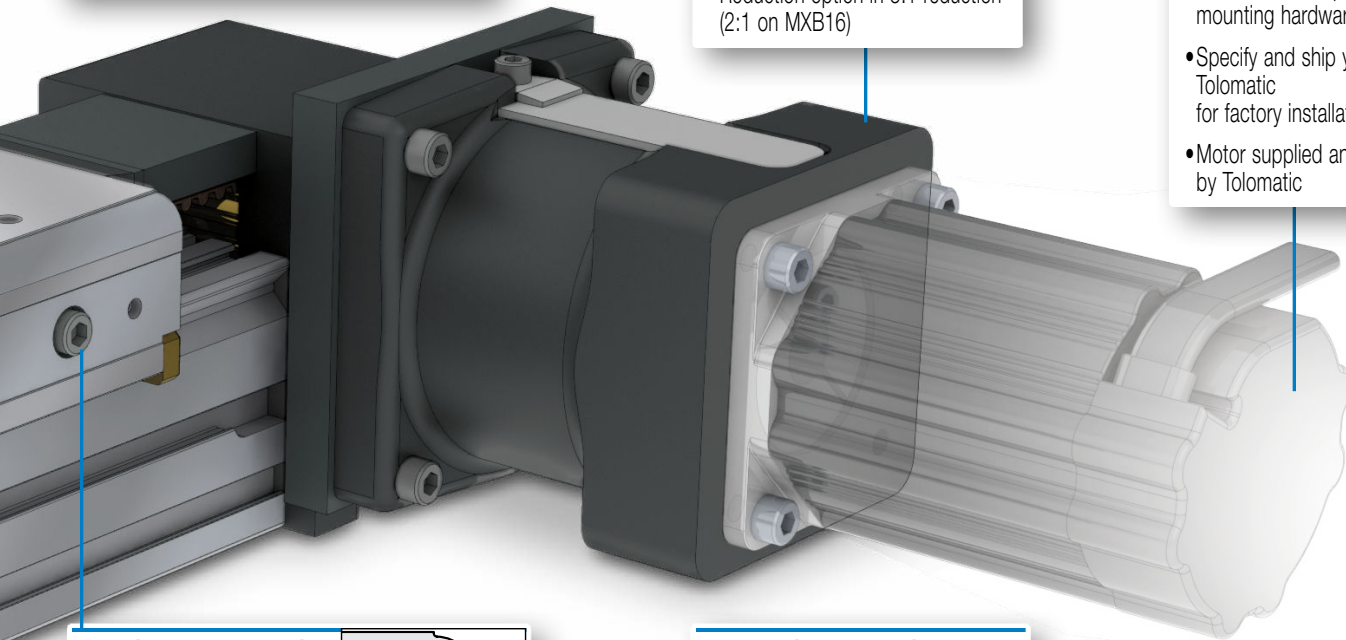

NON-BINDING BEARING ARMS

Bearings are tensioned indirectly, providing bind free adjustment

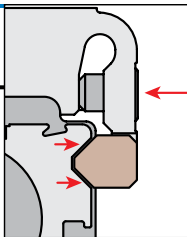

LIGHTWEIGHT ALUMINUM DESIGN

Clear anodized extrusion design is optimized for rigidity and strength

OPTIONS



AUXILIARY CARRIER **D****C**

- 2X higher Fz (load) capacity
- High bending moment capacity



FLOATING MOUNT **F****L**

- Compensates for non-parallelism between MX actuator and externally guided load



TUBE CLAMPS **T****C**

- Used for intermediate support
- Flush with bottom of actuator to retain low profile
- Drop-in, adjustable mounting locations (MXB16 uses T-nuts with mounting plates)

NOTE: Boxed letters indicate ordering codes



MOUNTING PLATES **M****P**

- Provides clearance for motor and mount
- 16,25,32 sizes attach with T-Nuts
- 40,50,63 sizes attach with Tube Clamps



HEAD COVER PLATE **H****C****2**

- Provides protection for pulley and bearing



SWITCHES

- Wide variety of sensing choices: Reed, Solid State PNP or NPN, available normally open or normally closed
- Flush mount, drop-in installation
- Bright LEDs, power & signal indication
- CE rated, RoHS compliant

MXB-**P** PROFILED RAIL BELT-DRIVE ACTUATOR

ENDURANCE TECHNOLOGYSM

A Tolomatic Design Principle

Endurance TechnologySM features are designed for maximum durability to provide extended service life.

The MXB-P rodless electric belt-drive actuator is designed for applications requiring moderate to heavy load carrying and guidance. The MXB-P actuator features a profiled rail system with recirculating ball linear guides for optimal performance. The MXB-P belt-driven actuator features speeds up to 3810 mm/sec (150 in/sec) and thrusts up to 1859 N (418 lbf). Built-to-order in stroke lengths up to 10,500 mm (414 in).

LOW CARRIER HEIGHT

- Reduces overall actuator envelope
- Large mounting pattern for excellent load stability

DURABLE BELT MATERIAL

High power polyurethane HTD tooth profile belt with steel tensile members resists stretching

OVERSIZED PULLEY BEARINGS

Drive shaft assembly incorporates oversized shielded/sealed ball bearings for long life and high speeds

MOTOR ORIENTATION

YOU CAN CHOOSE:

- Direct drive option directly couples motor to the drive shaft; one-piece housing construction for optimum alignment and support of the motor
- Reduction option in 3:1 reduction (2:1 on MXB16)

YOUR MOTOR HERE

YOU CAN CHOOSE:

- Specify the device to be installed and actuator ships with proper mounting hardware
- Specify and ship your device to Tolomatic for factory installation
- Motor supplied and installed by Tolomatic

INCH OR METRIC MOUNTING

Your choice of blank, inch (US standard) or metric mounting to the plate

LIGHTWEIGHT ALUMINUM DESIGN

Clear anodized extrusion design is optimized for rigidity and strength

EXTERNAL BUMPERS

Polyurethane bumpers protect the belt and clamp assembly from damage at end-of-stroke

BELT TENSIONING SYSTEM

The open slot on the guide plate permits easy access to the belt tensioning screw. No disassembly required

RECIRCULATING BALL BEARINGS

- Recirculating ball bearings are used to reduce friction and extend actuator life
- Designed with a grease pocket between ball elements to reduce friction, noise and maintenance
- Large permissible moment loads
- High speed operation, low heat generation
- High precision, smooth, low friction motion

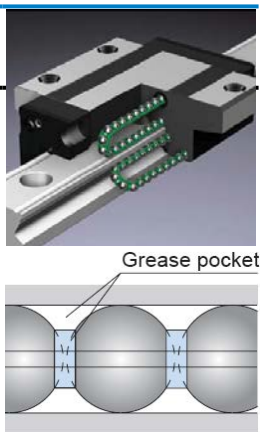

NOTE: Boxed letters indicate ordering codes

OPTIONS



AUXILIARY CARRIER **D****C**

- 2X higher Fz & Fy (load) capacity
- High bending moment capacity



MOUNTING PLATES **M****P**

- Provides clearance for motor and mount
- 16,25,32 sizes attach with T-Nuts
- 40,50,63 sizes attach with Tube Clamps



TUBE CLAMPS **T****C**

- Used for intermediate support
 - Flush with bottom of actuator to retain low profile
 - Drop-in adjustable mounting locations
- (Not available on the 16, 25 or 32 MXB-P sizes)



HEAD COVER PLATE **H****C****2**

- Provides protection for pulley and bearing



SWITCHES

- Wide variety of sensing choices: Reed, Solid State PNP or NPN, available normally open or normally closed
- Flush mount, drop-in installation
- Bright LEDs, power & signal indication
- CE rated, RoHS compliant

MXB Rodless Belt Drive Actuators

ACTUATOR SPECIFICATIONS AND BREAKAWAY TORQUE

MXB SIZE	MXB U , S & P					BREAKAWAY TORQUE	
	BELT WIDTH mm	BELT DEAD LENGTH mm	PULLEY PITCH DIA. mm	STROKE PER REV. mm	MAX. STROKE m	SINGLE CARRIER N-m	AUX. CARRIER OPT. (MXB-P) N-m
16	10	363.0	19.1	60.1	5.84	0.452	0.678
25	18	475.5	25.5	80.0	10.5	0.565	0.791
32	25	556.0	31.8	100.0	10.5	0.904	1.130
40	30	633.7	38.2	120.0	10.5	1.130	1.356
50	40	692.2	44.6	140.0	10.4	1.695	2.034
63	50	917.2	54.1	170.0	5.51	2.260	2.825

MXB SIZE	MXB U , S & P					BREAKAWAY TORQUE	
	BELT WIDTH in	BELT DEAD LENGTH in	PULLEY PITCH DIA. in	STROKE PER REV. in	MAX. STROKE in	SINGLE CARRIER lb-in	AUX. CARRIER OPT. (MXB-P) lb-in
16	0.39	14.29	0.753	2.366	230	4.0	6.0
25	0.71	18.72	1.003	3.151	414	5.0	7.0
32	0.98	21.89	1.253	3.936	413	8.0	10.0
40	1.18	24.95	1.504	4.725	412	10.0	12.0
50	1.57	27.25	1.754	5.510	410	15.0	18.0
63	1.97	36.11	2.130	6.692	217	20.0	25.0

MXB-J SIZE	WEIGHT				INERTIA		
	PLATE ASSEMBLY kg	BELT TENSIONER ASSEMBLY kg	BASE ACTUATOR kg	PER cm OF STROKE kg/cm	DRIVE/IDLE PULLEY ASSEMBLIES kg-cm ²	PLATE ASSEMBLY (INCLUDING BELT TENSIONER ASSEMBLY) kg-cm ²	PER cm OF STROKE kg-cm ²
16	0.05	0.05	0.72	0.0150	0.0250	0.0870	0.0006
25	0.12	0.07	1.17	0.0246	0.0759	0.3073	0.0020
32	0.22	0.13	1.89	0.0423	0.4143	0.8906	0.0043
40	0.41	0.21	3.55	0.0629	1.0884	2.2430	0.0075
50	0.47	0.33	4.50	0.0843	2.1196	3.9449	0.0135
63	1.15	0.38	7.46	0.1488	5.7101	11.1931	0.0249

MXB-J SIZE	WEIGHT				INERTIA		
	PLATE ASSEMBLY lb	BELT TENSIONER ASSEMBLY lb	BASE ACTUATOR lb	PER in OF STROKE lb/in	DRIVE/IDLE PULLEY ASSEMBLIES lb-in ²	PLATE ASSEMBLY (INCLUDING BELT TENSIONER ASSEMBLY) lb-in ²	PER in OF STROKE lb-in ²
16	0.11	0.10	1.59	0.084	0.0085	0.0297	0.0005
25	0.27	0.15	2.59	0.138	0.0259	0.1050	0.0017
32	0.48	0.30	4.17	0.237	0.1416	0.3043	0.0037
40	0.90	0.46	7.83	0.352	0.3719	0.7665	0.0065
50	1.03	0.72	9.93	0.472	0.7243	1.3480	0.0117
63	2.54	0.83	16.44	0.833	1.9512	3.8249	0.0216

MXB-S SIZE	WEIGHT				INERTIA			
	CARRIER ASSEMBLY kg	BELT TENSIONER ASSEMBLY kg	BASE ACTUATOR kg	PER cm OF STROKE kg/cm	DRIVE/IDLE PULLEY ASSEMBLIES kg-cm ²	CARRIER ASSEMBLY (INCLUDING BELT TENSIONER ASSEMBLY)		PER cm OF STROKE kg-cm ²
						SINGLE CARRIER kg-cm ²	AUX. CARRIER OPT. kg-cm ²	
16	0.15	0.05	0.84	0.0150	0.0250	0.1782	0.3151	0.0006
25	0.24	0.07	1.65	0.0246	0.0759	0.5060	0.9035	0.0020
32	0.45	0.14	2.63	0.0423	0.4143	1.4879	2.6365	0.0043
40	0.80	0.21	5.06	0.0629	1.0884	3.6828	6.6119	0.0075
50	1.17	0.33	7.35	0.0843	2.1196	7.4111	13.1956	0.0135
63	3.42	0.38	14.56	0.1488	5.7101	27.7891	52.8158	0.0249

MXB-S SIZE	WEIGHT				INERTIA			
	CARRIER ASSEMBLY lb	BELT TENSIONER ASSEMBLY lb	BASE ACTUATOR lb	PER in OF STROKE lb/in	DRIVE/IDLE PULLEY ASSEMBLIES lb-in ²	CARRIER ASSEMBLY (INCLUDING BELT TENSIONER ASSEMBLY)		PER in OF STROKE lb-in ²
						SINGLE CARRIER lb-in ²	AUX. CARRIER OPT. lb-in ²	
16	0.33	0.10	1.86	0.084	0.0085	0.0609	0.1077	0.0005
25	0.54	0.15	3.64	0.138	0.0259	0.1729	0.3087	0.0017
32	1.00	0.30	5.80	0.237	0.1416	0.5084	0.9009	0.0037
40	1.77	0.46	11.16	0.352	0.3719	1.2585	2.2594	0.0065
50	2.57	0.72	16.20	0.472	0.7243	2.5325	4.5092	0.0117
63	7.54	0.83	32.10	0.833	1.9512	9.4960	18.0481	0.0216

MXB-P SIZE	WEIGHT				INERTIA			
	CARRIER ASSEMBLY kg	BELT TENSIONER ASSEMBLY kg	BASE ACTUATOR kg	PER cm OF STROKE kg/cm	DRIVE/IDLE PULLEY ASSEMBLIES kg-cm ²	CARRIER ASSEMBLY (INCLUDING BELT TENSIONER ASSEMBLY)		PER cm OF STROKE kg-cm ²
						SINGLE CARRIER kg-cm ²	AUX. CARRIER OPT. kg-cm ²	
16	0.18	0.05	1.08	0.0183	0.0250	0.2014	0.3615	0.0006
25	0.38	0.07	1.98	0.0348	0.0759	0.7297	1.3508	0.0020
32	0.74	0.13	3.55	0.0569	0.4143	2.2232	4.1072	0.0043
40	1.14	0.21	6.38	0.0959	1.0884	4.9138	9.0740	0.0075
50	2.28	0.33	9.45	0.1337	2.1196	12.9416	24.2565	0.0135
63	4.25	0.38	16.89	0.1981	5.7101	33.8324	64.9024	0.0249

MXB-P SIZE	WEIGHT				INERTIA			
	CARRIER ASSEMBLY lb	BELT TENSIONER ASSEMBLY lb	BASE ACTUATOR lb	PER in OF STROKE lb/in	DRIVE/IDLE PULLEY ASSEMBLIES lb-in ²	CARRIER ASSEMBLY (INCLUDING BELT TENSIONER ASSEMBLY)		PER in OF STROKE lb-in ²
						SINGLE CARRIER lb-in ²	AUX. CARRIER OPT. lb-in ²	
16	0.39	0.10	2.38	0.102	0.0085	0.0688	0.1235	0.0005
25	0.84	0.15	4.36	0.195	0.0259	0.2493	0.4616	0.0017
32	1.64	0.30	7.83	0.318	0.1416	0.7597	1.4035	0.0037
40	2.51	0.46	14.07	0.537	0.3719	1.6791	3.1007	0.0065
50	5.03	0.72	20.84	0.749	0.7243	4.4224	8.2889	0.0117
63	9.36	0.83	37.24	1.110	1.9512	11.5611	22.1783	0.0216

MAXIMUM VELOCITY **U** 5080 mm/sec *200 in/sec*

MAXIMUM VELOCITY **S** 2540 mm/sec *100 in/sec*

MAXIMUM VELOCITY **P** 3810 mm/sec *150 in/sec*

MAXIMUM ACCELERATION 30.48 m/sec² *1200 in/sec²*

REPEATABILITY ± 0.051 mm *± 0.002 in*

TEMPERATURE RANGE -12 to 54 °C *10 to 130 °F*

⚠ Heat generated by the motor and drive should be taken into consideration as well as linear velocity and work cycle time. For applications that require operation outside of the recommended temperature range, contact the factory.

STRAIGHTNESS, FLATNESS 0.01702 L mm *0.00067 L in*
Actuator mounted on a flat surface and fully restrained (see Mounting Plate Requirements, page MXB_11) L = Maximum distance between supports

⚠ The listed values relating to straightness/flatness are intended for reference purposes only, and not as an engineering standard of absolute tolerance for a given actuator. Appropriate installation is the single most important factor in reducing variation, so good engineering practices such as measurement, mapping, etc. must be employed in applications with stringent straightness/flatness requirements.

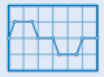

S & P TUBE CLAMP REQUIREMENTS

S SOLID BEARING

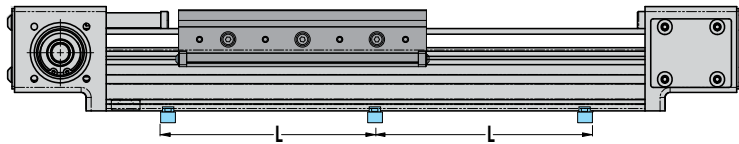
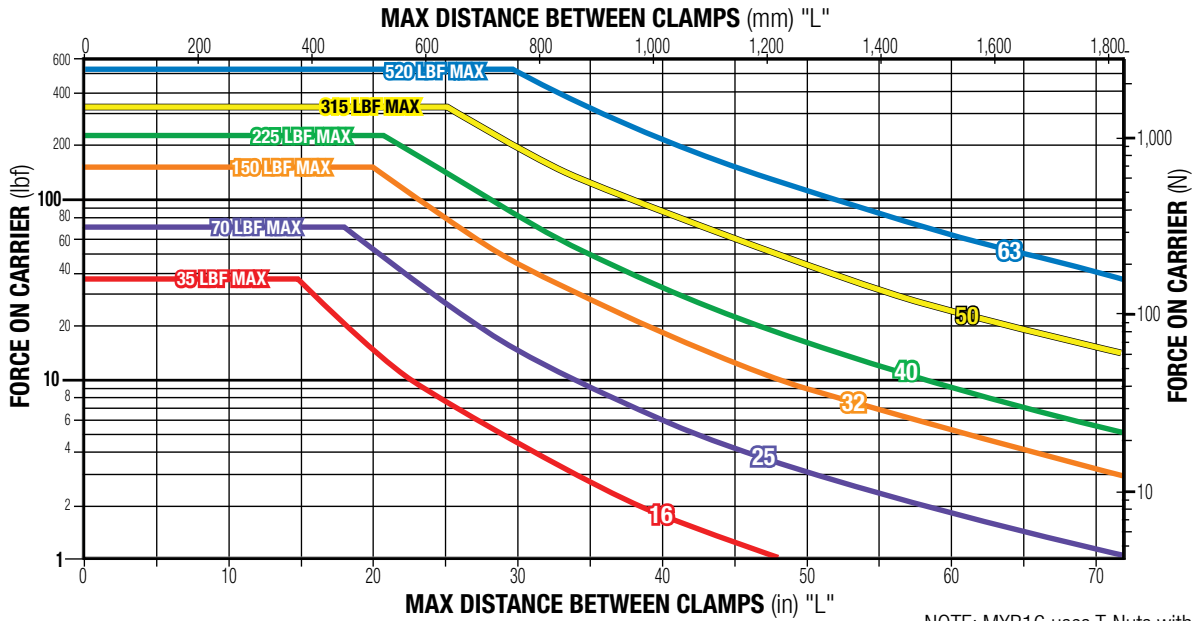

P PROFILE RAIL BEARING

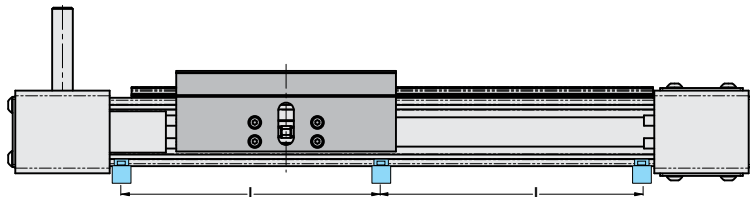
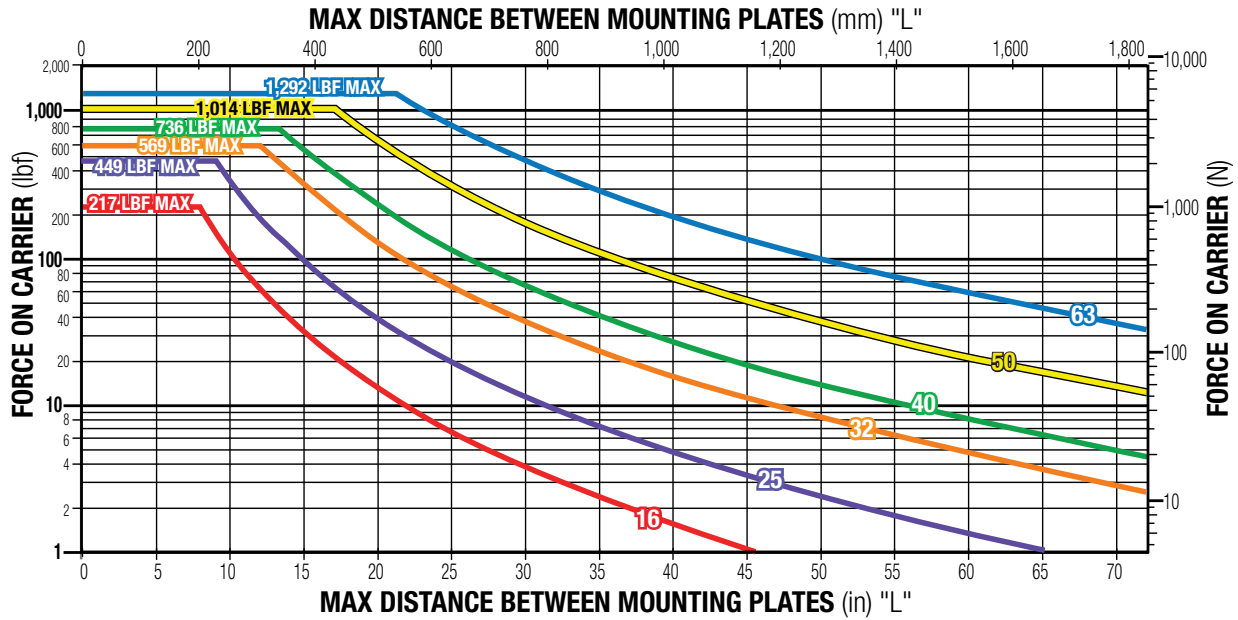

MXB-S Rodless Belt Drive Actuators

sizeit.tolomatic.com for fast, accurate actuator selection



S SOLID BEARING MOMENT AND LOAD CAPACITY

STANDARD CARRIER

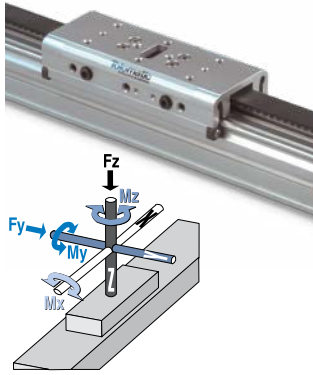

SIZE	MAX. BENDING MOMENTS			MAX. LOAD
	Mx	My	Mz	Fz
	N-m	N-m	N-m	N
16	2.5	2.1	2.8	156
25	6.8	12.4	3.8	311
32	11.3	39.5	15.8	667
40	31.1	67.8	24.9	1,001
50	35.6	131.0	38.5	1,401
63	66.1	264.0	58.8	2,313

SIZE	MAX. BENDING MOMENTS			MAX. LOAD
	Mx	My	Mz	Fz
	in-lbs	in-lbs	in-lbs	lbf
16	22	19	25	35
25	60	110	34	70
32	100	350	140	150
40	275	600	220	225
50	315	1,155	341	315
63	585	2,340	520	520

D/AUXILIARY CARRIER

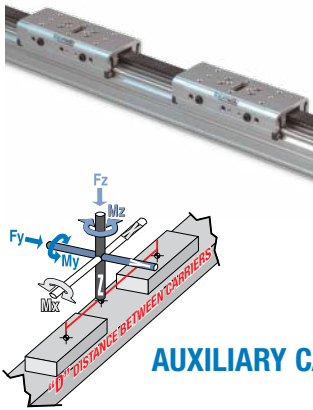

SIZE	"D" MIN. mm	MAX. BENDING MOMENTS*			MAX. LOAD
		Mxa	Mya	Mza	Fza
		N-m	N-m	N-m	N
16	127	5.0	19.8	19.8	311
25	152	13.6	47.5	47.5	623
32	178	22.6	119.0	119.0	1,334
40	216	62.1	216.0	216.0	2,002
50	218	71.2	306.0	306.0	2,802
63	330	132.0	764.0	764.0	4,626

SIZE	"D" MIN. in	MAX. BENDING MOMENTS*			MAX. LOAD
		Mxa	Mya	Mza	Fza
		in-lbs	in-lbs	in-lbs	lbf
16	5.0	44	175	175	70
25	6.0	120	420	420	140
32	7.0	200	1,050	1,050	300
40	8.5	550	1,913	1,913	450
50	8.6	630	2,709	2,709	630
63	13.0	1,170	6,760	6,760	1,040

*At minimum "D" distance see graph below for complete information

AUXILIARY CARRIER BENDING MOMENTS WITH INCREASED "D" DISTANCE BETWEEN CARRIERS

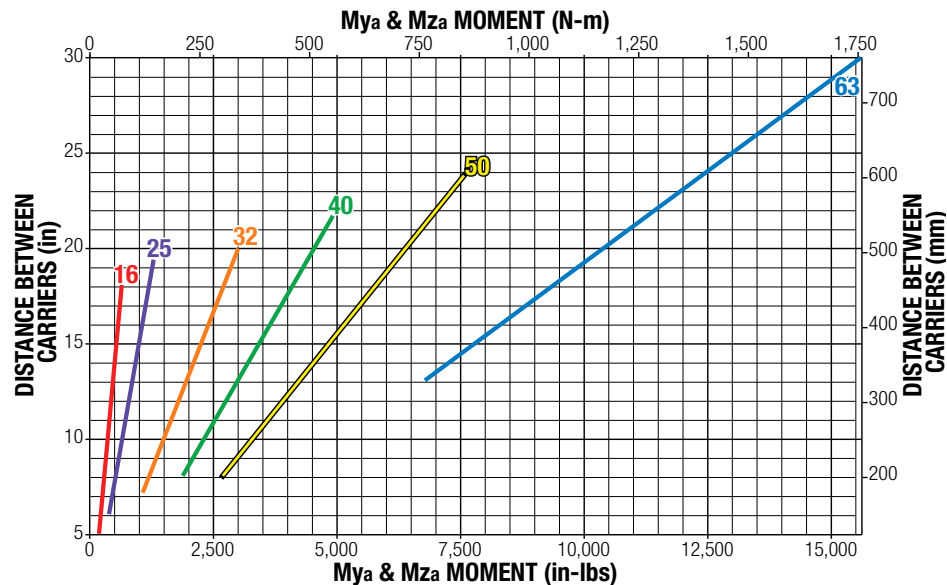

Ratings were calculated with the following conditions:

- 1.) Coupling between carriers is rigid.
- 2.) Load is equally distributed between carriers.
- 3.) Coupling device applies no misalignment loads to carriers.

⚠ The above ratings are the maximum values for shock-free, vibration-free operation in a typical industrial environment, which must not be exceeded even in dynamic operation. Contact Tolomatic for assistance in selecting the most appropriate actuator for your application.

The moment and load capacity of the actuator bearing system is based on an L10 life of 5,000 linear km (2x10⁹ in) of travel. Life of the actuator will vary for each application depending on the combined loads, motion parameters and operating conditions. The load factor (L_F) for each application must not exceed a value of 1, as calculated below. Exceeding a load factor of 1 will diminish the actuator rated life.

$$L_F = \frac{M_x}{M_{x_{max}}} + \frac{M_y}{M_{y_{max}}} + \frac{M_z}{M_{z_{max}}} + \frac{F_y}{F_{y_{max}}} + \frac{F_z}{F_{z_{max}}} \leq 1$$

With combined loads, L_F must not exceed the value 1.

MXB-P Rodless Belt Drive Actuators

PROFILED RAIL BEARING MOMENT AND LOAD CAPACITY

⚠ Mating surface of mounted component must maintain a flatness of at least 0.040 mm [0.0015"]

STANDARD CARRIER

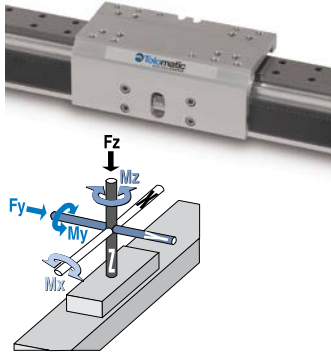

SIZE	MAX. BENDING MOMENTS			MAX. LOAD	MAX. THRUST
	Mx	My	Mz	Fy & Fz	THRUST
	N-m	N-m	N-m	N	N
16	4.5	38.3	38.3	966	169
25	14.3	56.7	42.6	1,996	672
32	25.6	152.0	152.0	2,531	930
40	68.2	216.0	216.0	3,274	1,112
50	91.7	394.0	394.0	4,510	1,446
63	115.0	603.0	603.0	5,745	1,859

SIZE	MAX. BENDING MOMENTS			MAX. LOAD	MAX. THRUST
	Mx	My	Mz	Fy & Fz	THRUST
	in-lbs	in-lbs	in-lbs	lbf	lbf
16	39	339	339	217	38
25	126	502	377	449	151
32	226	1,344	1,344	569	209
40	604	1,913	1,913	736	250
50	811	3,483	3,483	1,014	325
63	1,019	5,339	5,339	1,292	418

AUXILIARY CARRIER

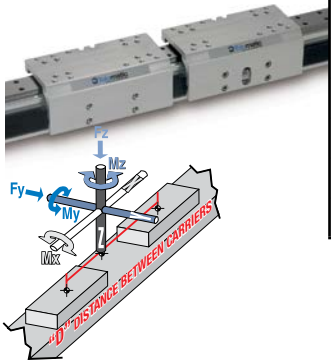

SIZE	"D" MIN.	MAX. BENDING MOMENTS			MAX. LOAD
		Mxa	Mya	Mza	Fya & Fza
		mm	N-m	N-m	N-m
16	127	8.9	70.0	70.0	1,932
25	152	28.5	182	182	3,993
32	178	51.1	249	249	5,063
40	216	136.0	407	407	6,549
50	218	183.0	561	561	9,020
63	330	230.0	1,074	1,074	11,490

SIZE	"D" MIN.	MAX. BENDING MOMENTS			MAX. LOAD
		Mxa	Mya	Mza	Fya & Fza
		in	in-lbs	in-lbs	in-lbs
16	5.0	79	620	620	434
25	6.0	252	1,610	1,610	898
32	7.0	453	2,202	2,202	1,138
40	8.5	1,208	3,601	3,601	1,472
50	8.6	1,623	4,966	4,966	2,028
63	13.0	2,038	9,508	9,508	2,583

*At minimum "D" distance - see graph below for bending moments at greater distances

AUXILIARY CARRIER BENDING MOMENTS WITH INCREASED "D" DISTANCE BETWEEN CARRIERS

Ratings were calculated with the following conditions:

- 1.) Coupling between carriers is rigid.
- 2.) Load is equally distributed between carriers.
- 3.) Coupling device applies no misalignment loads to carriers.

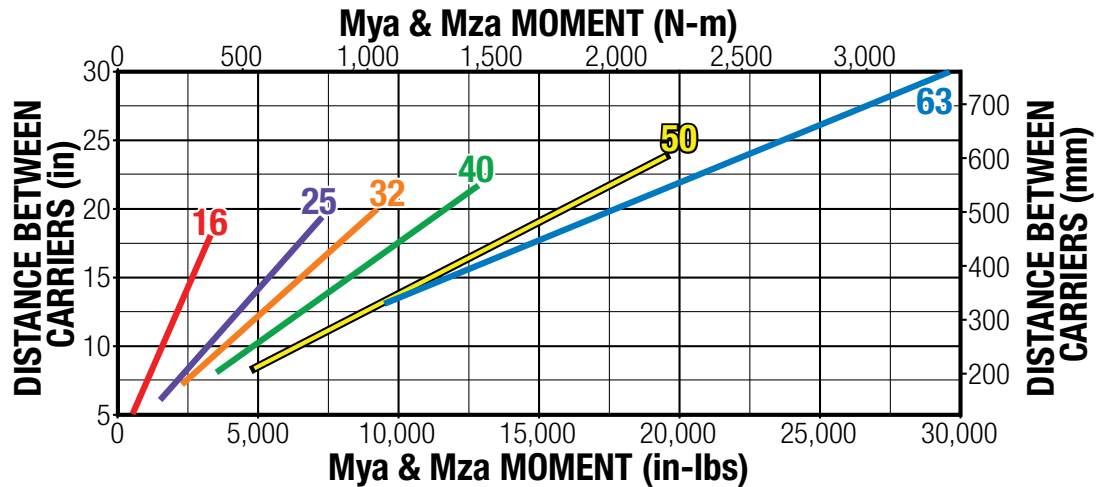

⚠ The above ratings are the maximum values for shock-free, vibration-free operation in a typical industrial environment, which must not be exceeded even in dynamic operation. Contact Tolomatic for assistance in selecting the most appropriate actuator for your application.

The moment and load capacity of the actuator bearing system is based on an L10 life of 5,000 linear km (2x10⁹ in) of travel. Life of the actuator will vary for each application depending on the combined loads, motion parameters and operating conditions. The load factor (L_F) for each application must not exceed a value of 1, as calculated below. Exceeding a load factor of 1 will diminish the actuator rated life.

$$L_F = \frac{M_x}{M_{x_{max}}} + \frac{M_y}{M_{y_{max}}} + \frac{M_z}{M_{z_{max}}} + \frac{F_y}{F_{y_{max}}} + \frac{F_z}{F_{z_{max}}} \leq 1$$

With combined loads, L_F must not exceed the value 1.

MXB-P Rodless Belt Drive Actuator

sizeit.tolomatic.com for fast, accurate actuator selection



LOAD DEFLECTION

DEFLECTION TESTING WAS DONE UNDER THESE CRITERIA:

- 1.) Actuator was properly mounted with distance between mounting plates within recommendations
- 2.) Deflection was measured at 12" from center of carrier as shown (see Mounting Plate Requirements page mnt_11)

DEFLECTION ABOUT X AXIS

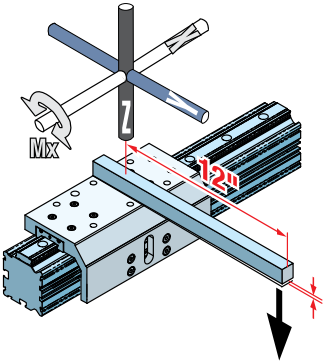
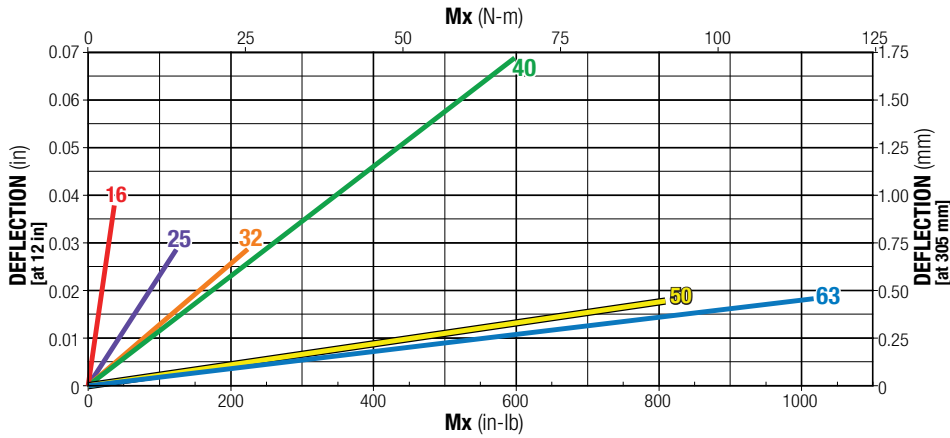

DEFLECTION ABOUT Y AXIS

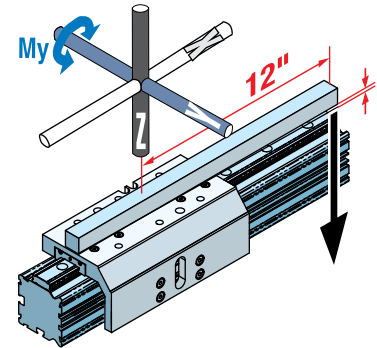
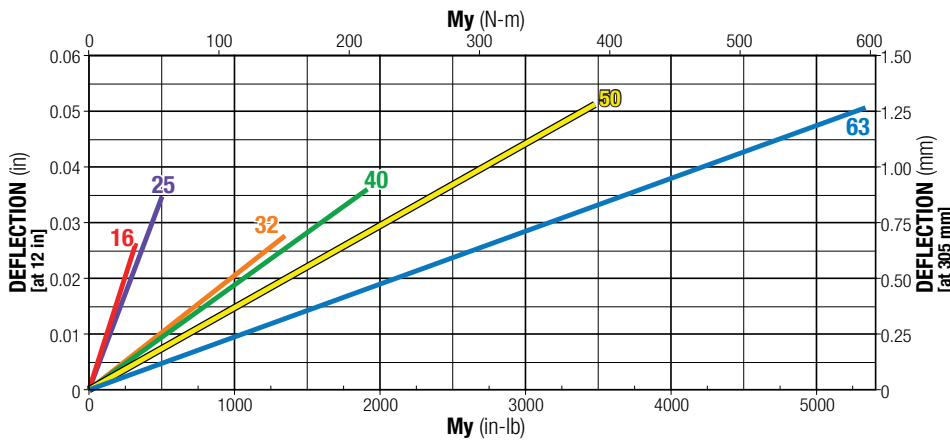

DEFLECTION ABOUT Z AXIS

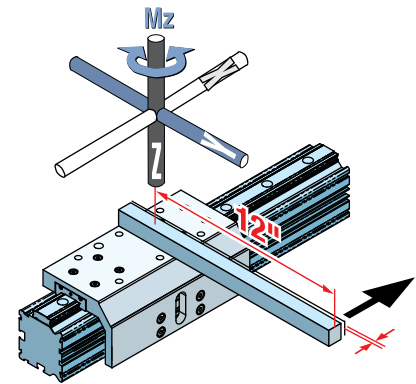
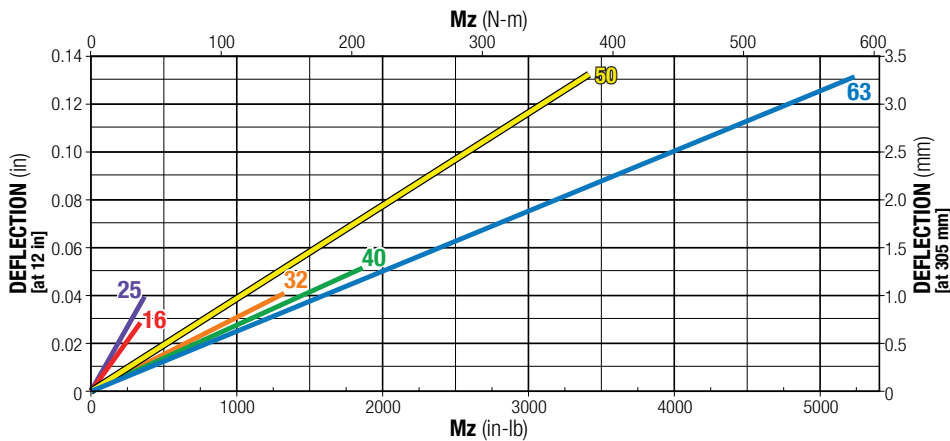

MXB Rodless Belt Drive Actuators

U UNGUIDED: MAXIMUM ACCELERATION AS A FUNCTION OF EXTERNALLY GUIDED LOAD WEIGHT

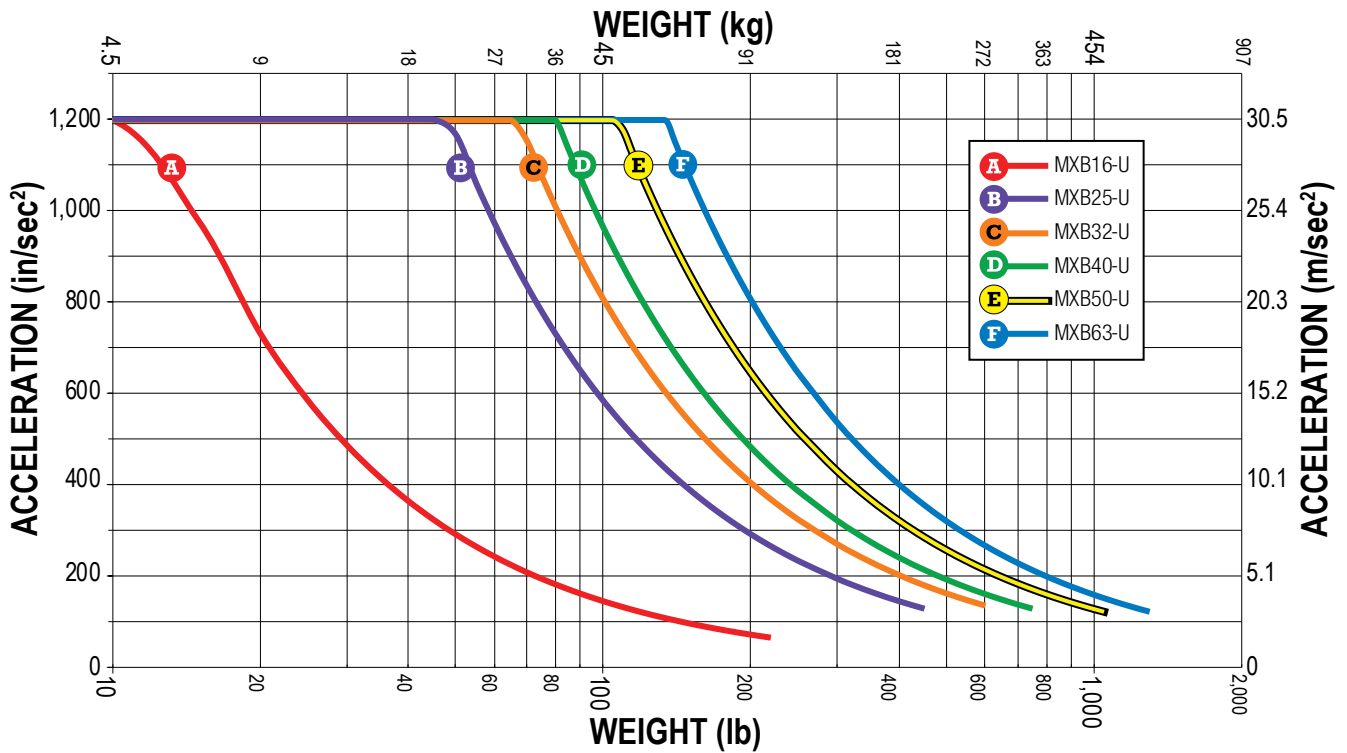

S SOLID BEARING: MAXIMUM ACCELERATION AS A FUNCTION OF LOAD WEIGHT

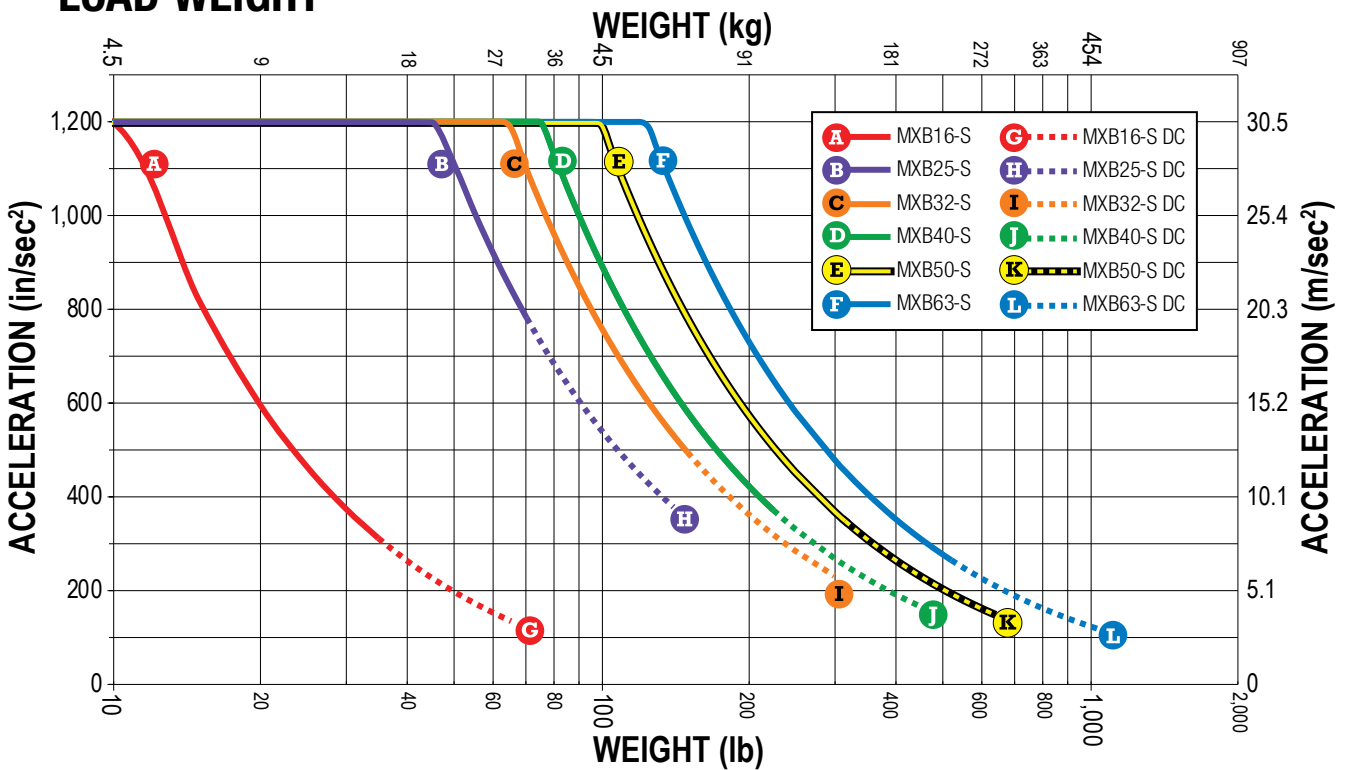

MXB Rodless Belt Drive Actuators

PROFILED RAIL: MAXIMUM ACCELERATION AS A FUNCTION OF LOAD WEIGHT

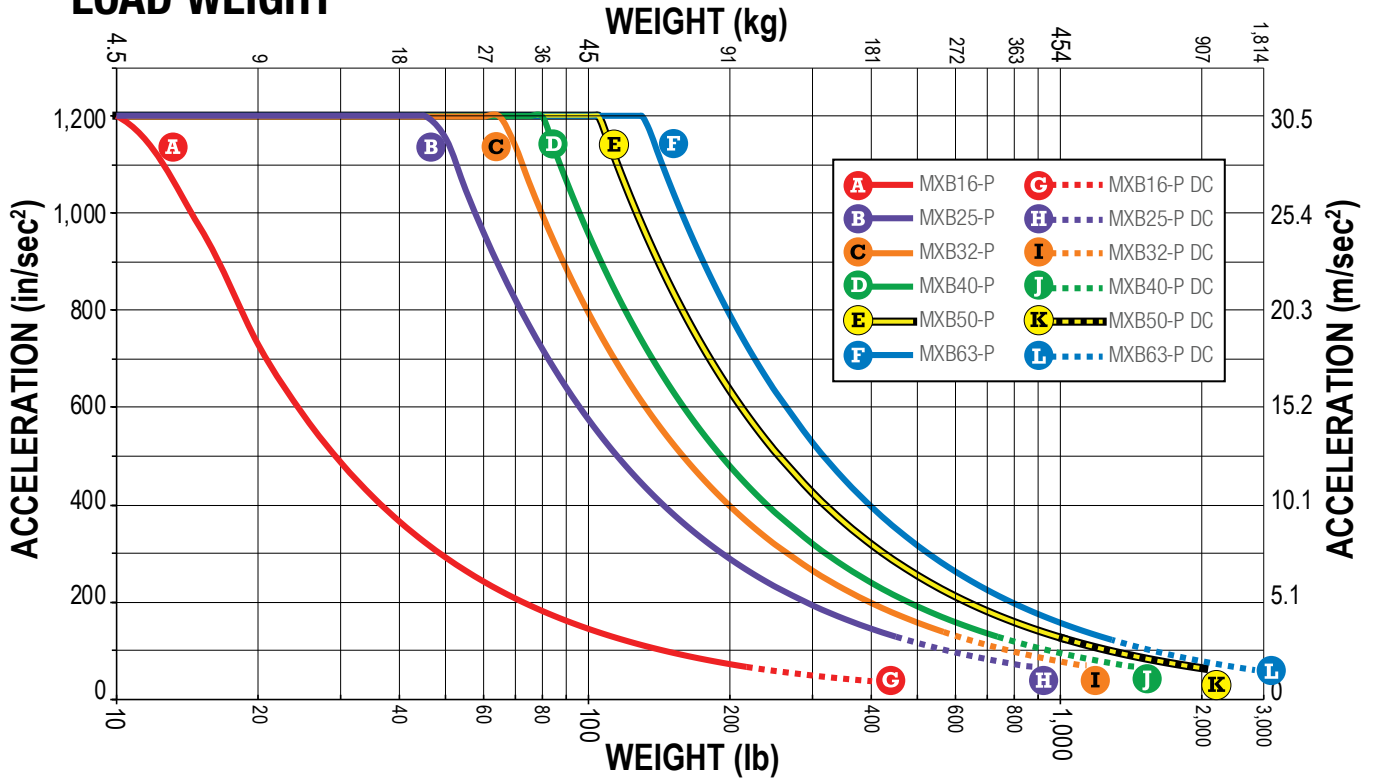

SPEED FACTOR

FOR APPLICATIONS WITH HIGH SPEED OR SIGNIFICANT SHOCK AND VIBRATION: Calculated values of loads and bending moments must be increased by speed factor from the graph at right to obtain full rated life of profiled rail bearing system.

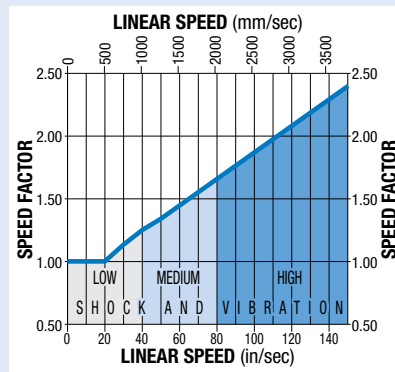

PROFILED RAIL LUBRICATION

Proper lubrication of profiled rail bearing system is essential for normal operation and achievement of full rated life of MX--P actuators. Lubrication should be performed at intervals of 101 km (4x10⁹ in) of travel or once every year, whichever occurs first. **However, operating conditions such as high speed or significant shock and vibration may require more frequent lubrication.** Please consult Tolomatic for recommendations.

Recommended grease types:

1. Refined mineral oil-based multi-purpose grease with lithium thickening agent.
2. High-grade synthetic oil-based grease with urea thickening agent.

MXB-S Rodless Belt Drive Actuator

tolomatic.com/CAD Download 3D CAD
Always use CAD solid model to determine
critical dimensions



SOLID BEARING DIMENSIONS

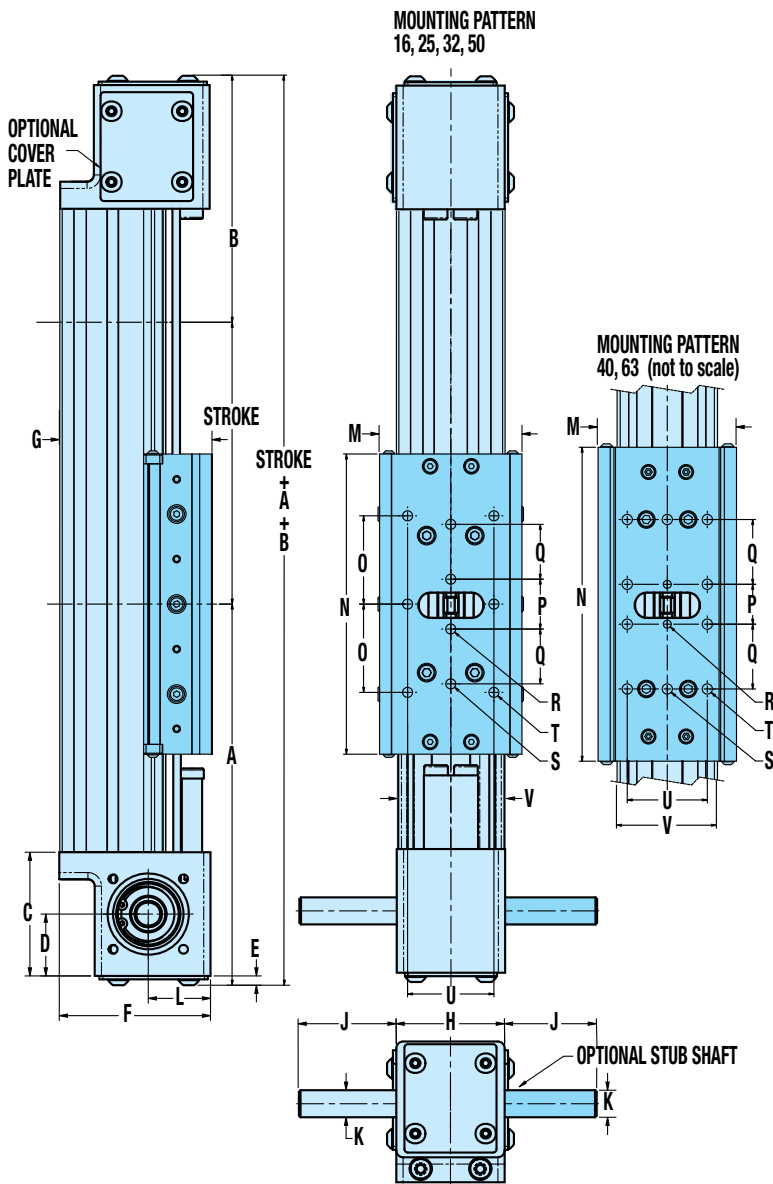

	MXB16	MXB25	MXB32	MXB40	MXB50	MXB63
A	135.3	173.9	179.3	216.6	217.8	275.1
B	119.0	139.3	163.2	192.7	212.0	262.1
C	50.8	58.0	55.9	78.7	82.6	96.1
D	25.4	29.0	25.4	39.4	40.0	45.3
E	3.8	4.4	4.4	4.4	4.4	4.4
F	52.8	66.0	77.5	93.8	110.6	139.3
G*	45.8	58.4	77.8	89.2	112.8	139.7
H	44.5	50.8	69.9	82.6	98.4	111.1
(LMI) J	15.0	57.7	57.7	47.5	47.5	47.5
(RP) J	46.6	57.7	57.7	47.5	47.5	47.5
K	Ø9.53	Ø12.70	Ø12.70	Ø12.70	Ø12.70	Ø12.70
L	26.4	29.2	27.9	39.7	41.5	52.2
M	40.1	55.4	72.6	88.2	104.1	142
N	110.0	134.9	153	200	200.9	307.6
O	30	39.9	45	-	47.8	-
P	-	25.4	25.4	25.4	63.5	76.2
Q	-	27.2	28	41.3	31.8	38.1
R	-	M6x1.0 (2)	M8x1.25 (2)	M8x1.25 (2)	M10x1.5 (2)	M10x1.5 (2)
S	-	M6x1.0 (2)	M8x1.25 (2)	M8x1.25 (2)	M10x1.5 (2)	M10x1.5 (2)
T	M4x0.7 (6)	M6x1.0 (6)	M8x1.25 (6)	M8x1.25 (8)	M10x1.5 (6)	M10x1.5 (8)
U*	30.0	30.0	44.0	51.0	65.8	82.6
V	30.00	42.00	55.37	64.00	78.74	100.00

Dimensions in millimeters

	MXB16	MXB25	MXB32	MXB40	MXB50	MXB63
A	5.33	6.85	7.06	8.53	8.57	10.83
B	4.69	5.49	6.43	7.59	8.34	10.33
C	2.00	2.28	2.20	3.10	3.25	3.79
D	1.00	1.14	1.00	1.55	1.58	1.79
E	0.15	0.17	0.17	0.17	0.17	0.17
F	2.08	2.60	3.05	3.69	4.35	5.48
G*	1.80	2.30	3.06	3.51	4.44	5.50
H	1.75	2.00	2.75	3.25	3.88	4.38
(LMI) J	0.59	2.27	2.27	1.87	1.87	1.87
(RP) J	1.83	2.27	2.27	1.87	1.87	1.87
K	Ø0.375	Ø0.500	Ø0.500	Ø0.500	Ø0.500	Ø0.500
L	1.04	1.15	1.10	1.56	1.63	2.06
M	1.58	2.18	2.86	3.47	4.1	5.59
N	4.33	5.31	6.02	7.87	7.91	12.11
O	1.18	1.57	1.77	-	1.88	-
P	-	1.00	1.00	1.00	2.50	3.00
Q	-	1.07	1.10	1.63	1.25	1.50
R	-	1/4-20 (2)	1/4-20 (2)	1/4-20 (2)	3/8-16 (2)	3/8-16 (2)
S	-	#10-32 (2)	1/4-20 (2)	5/16-18 (2)	3/8-16 (2)	3/8-16 (2)
T	#8-32 (6)	1/4-20 (6)	1/4-20 (6)	5/16-18 (8)	3/8-16 (6)	3/8-16 (8)
U*	1.18	1.18	1.73	2.00	2.59	3.25
V	1.18	1.65	2.18	2.52	3.10	3.94

Dimensions in inches

MXB-S Rodless Belt Drive Actuator

SOLID BEARING OPTION DIMENSIONS

tolomatic.com/CAD Download 3D CAD
Always use CAD solid model to determine
critical dimensions

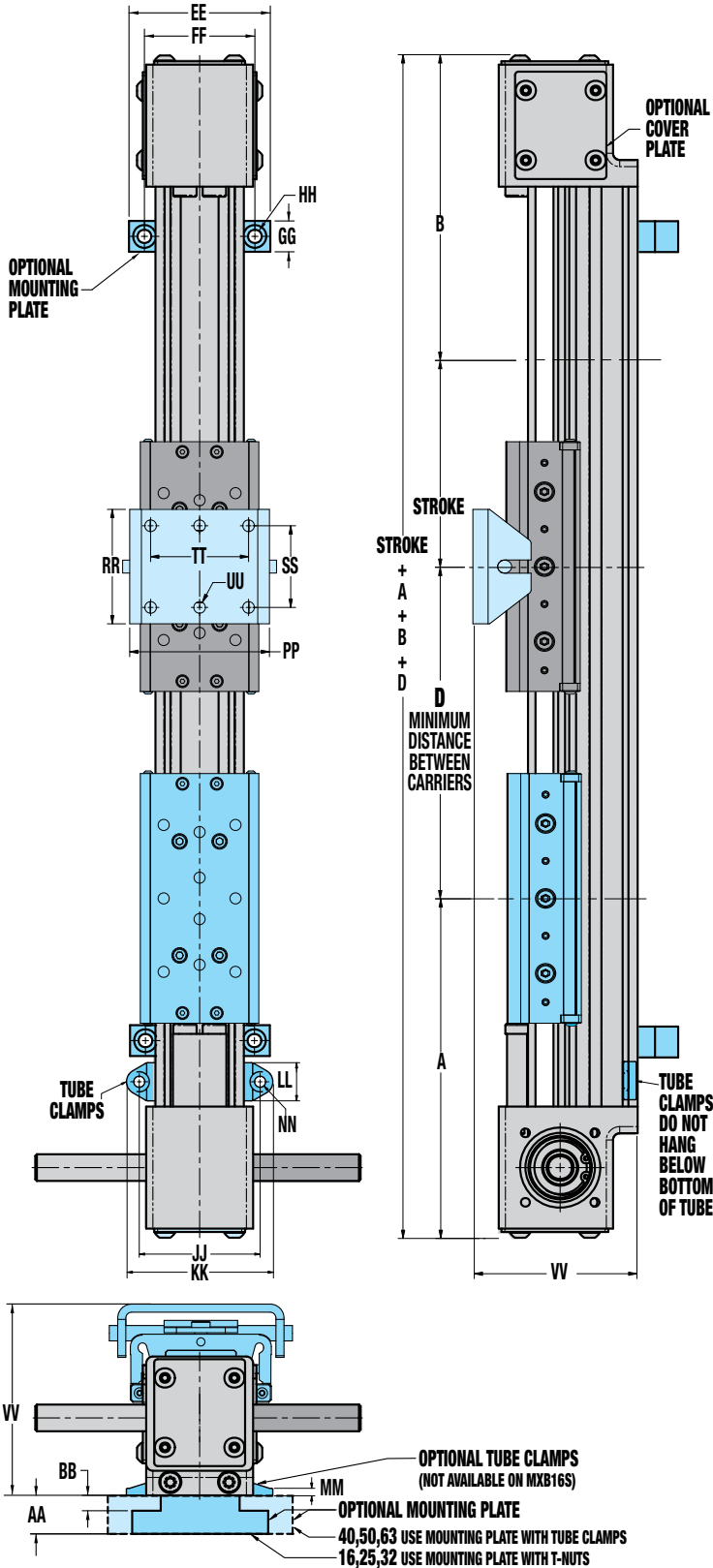

	MXB16	MXB25	MXB32	MXB40	MXB50	MXB63
A	135.3	173.9	179.3	216.6	217.8	275.1
B	119.0	139.3	163.2	192.7	212.0	262.1
D	127.0	152.4	177.0	215.9	216.4	330.2

OPTIONAL MOUNTING PLATES

AA	15.9	15.9	19.1	25.4	31.8	25.4
BB	6.4	6.4	7.6	-	-	-
DD	60.9	77.7	95.2	106.1	127.4	153.3
EE	60.0	63.5	86.4	127.0	142.2	203.2
FF	44.5	50.8	59.9	112.0	127.0	177.8
GG	25.4	25.4	25.4	20.1	20.1	25.4
HH	Ø5.6 THRU └┘09.4 ▽5.6 (2)	Ø5.6 THRU └┘09.4 ▽5.6 (2)	Ø7.1 THRU └┘Ø11.2 ▽7.1 (2)	Ø7.1 THRU (2)	Ø7.1 THRU (2)	Ø7.1 THRU (2)

OPTIONAL TUBE CLAMPS

JJ	-	57.0	74.1	82.7	97.5	131.7
KK	-	69.0	87.4	96.7	111.5	150.7
LL	-	18.0	16.0	14.0	14.0	19.0
MM	-	3.6	4.3	3.8	3.8	6.1
NN	-	5.2	7.1	7.1	7.1	10.7

OPTIONAL FLOATING MOUNT

PP	47.2	64.1	93.3	109.7	128.0	154.9
RR	24.9	31.8	70.1	100.0	100.0	127.0
SS	11.9	15.9	50.0	74.9	80.0	100.1
TT	-	-	-	55.1	-	70.1
UU	Ø4.6 (2)	Ø6.1 (2)	Ø7.1 (2)	Ø7.1 (4)	Ø9.1 (2)	Ø8.6 (4)
VV	58.5	70.9	93.3	108.2	133.1	156.8

Dimensions in millimeters

	MXB16	MXB25	MXB32	MXB40	MXB50	MXB63
A	5.33	6.85	7.06	8.53	8.57	10.83
B	4.69	5.49	6.43	7.59	8.34	10.33
D	5.00	6.00	7.00	8.50	8.60	13.00

OPTIONAL MOUNTING PLATES

AA	0.63	0.63	0.75	1.00	1.25	1.00
BB	0.25	0.25	0.30	-	-	-
DD	2.4	3.06	3.75	4.18	5.01	6.04
EE	2.36	2.50	3.40	5.00	5.60	8.00
FF	1.75	2.00	2.75	4.41	5.00	7.00
GG	1.00	1.00	1.00	0.79	0.79	1.00
HH	Ø.22 THRU └┘0.37 ▽.22 (2)	Ø.22 THRU └┘0.37 ▽.22 (2)	Ø.28 THRU └┘0.44 ▽.28 (2)	Ø.28 THRU (2)	Ø.28 THRU (2)	Ø.28 THRU (2)

OPTIONAL TUBE CLAMPS

JJ	-	2.24	2.92	3.26	3.84	5.19
KK	-	2.72	3.44	3.81	4.39	5.93
LL	-	0.71	0.63	0.55	0.55	0.75
MM	-	0.14	0.17	0.15	0.15	0.24
NN	-	0.20	0.28	0.28	0.28	0.42

OPTIONAL FLOATING MOUNT

PP	1.86	2.52	3.37	4.32	5.04	6.10
RR	0.98	1.25	2.76	3.94	3.94	5.00
SS	0.47	0.63	1.97	2.95	3.15	3.94
TT	-	-	-	2.17	-	2.76
UU	Ø.18 (2)	Ø.24 (2)	Ø.28 (2)	Ø.28 (4)	Ø.36 (2)	Ø.34 (4)
VV	2.30	2.79	3.67	4.26	5.24	6.18

Dimensions in inches

MXB-P Rodless Belt Drive Actuator

tolomatic.com/CAD Download 3D CAD
Always use CAD solid model to determine
critical dimensions



PROFILED RAIL BEARING DIMENSIONS

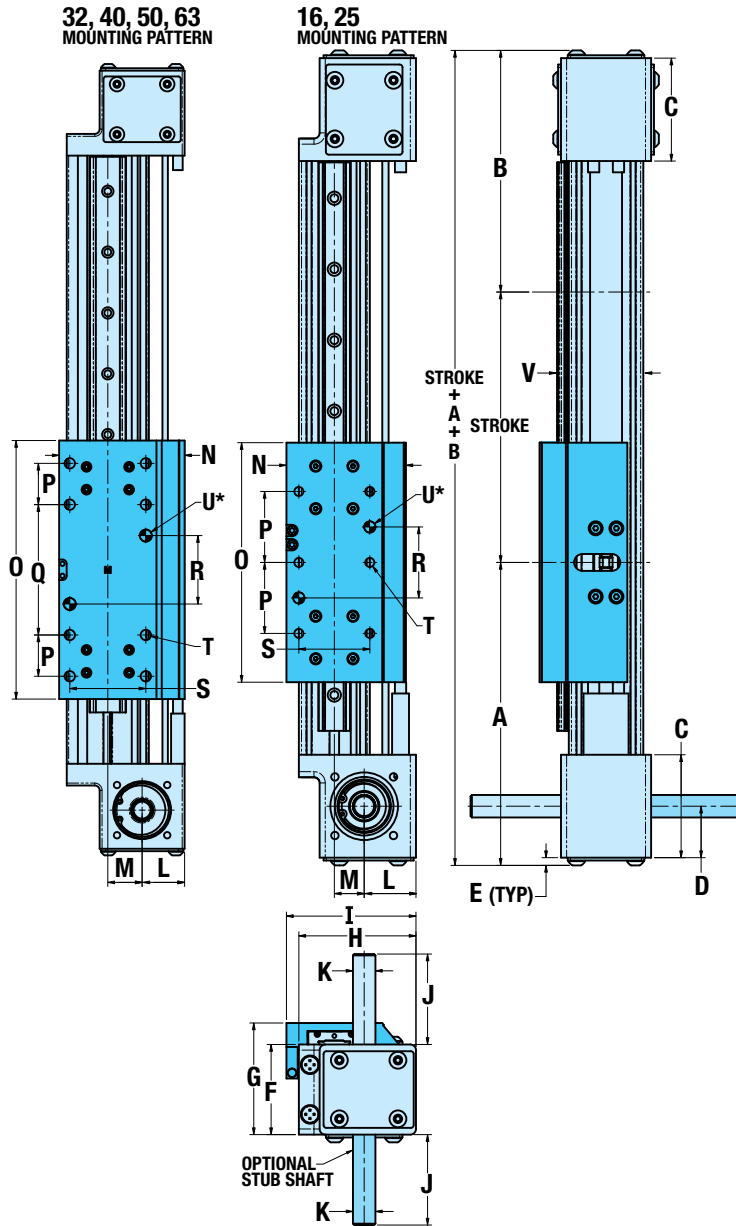

	MXB16	MXB25	MXB32	MXB40	MXB50	MXB63
A	135.3	173.9	187.8	216.6	224.7	275.1
B	119.0	139.3	154.7	192.7	205.0	262.1
C	50.8	58.0	55.9	78.7	82.6	96.1
D	25.4	29.0	25.4	39.4	40.0	45.3
E	3.8	4.4	4.4	4.4	4.4	4.4
F	44.5	50.8	69.9	82.6	98.4	111.1
G	53.2	62.9	84.6	98.7	129.6	145.6
H	52.8	66.0	77.5	93.8	110.6	139.3
I	54.8	73.0	82.5	103.9	117.9	147.1
(LM)J	15.0	57.7	57.7	47.5	47.5	47.5
(RP)J	46.6	57.7	57.7	47.5	47.5	47.5
K	Ø9.53	Ø12.70	Ø12.70	Ø12.70	Ø12.70	Ø12.70
L	26.4	29.2	27.9	39.7	41.5	52.2
M	11.4	16.8	22.6	22.2	29.8	37.1
N	45.3	67.4	82.5	97.8	117.4	150.6
O	110.0	135.0	170.0	200.0	216.0	304.8
P	40.0	40.0	27.1	25.4	25.4	40.0
Q	—	—	85.7	114.3	69.8	130.0
R	40.00	40.00	45.00	63.50	38.10	65.00
S	28.00	40.00	50.00	72.00	79.38	98.30
T	M4x0.7	M6x1.0	M8x1.25	M8x1.25	M8x1.25	M10x1.5
U*	Ø4.045 / 4.020 ∇6.35	Ø6.045 / 6.020 ∇6.35	Ø8.045 / 8.020 ∇9.53	Ø8.045 / 8.020 ∇12.70	Ø8.045 / 8.020 ∇12.70	Ø10.045 / 10.020 ∇12.70
V	35.50	48.60	62.87	73.50	93.74	115.00

Dimensions in millimeters

	MXB16	MXB25	MXB32	MXB40	MXB50	MXB63
A	5.33	6.85	7.39	8.53	8.85	10.83
B	4.69	5.49	6.09	7.59	8.07	10.33
C	2.00	2.28	2.20	3.10	3.25	3.79
D	1.00	1.14	1.00	1.55	1.58	1.79
E	0.15	0.17	0.17	0.17	0.17	0.17
F	1.75	2.00	2.75	3.25	3.88	4.38
G	2.10	2.48	3.33	3.88	5.10	5.73
H	2.08	2.60	3.05	3.69	4.35	5.48
I	2.16	2.87	3.25	4.09	4.64	5.79
(LM)J	0.59	2.27	2.27	1.87	1.87	1.87
(RP)J	1.83	2.27	2.27	1.87	1.87	1.87
K	Ø0.375	Ø0.500	Ø0.500	Ø0.500	Ø0.500	Ø0.500
L	1.04	1.15	1.10	1.56	1.63	2.06
M	0.45	0.66	0.89	0.87	1.17	1.46
N	1.78	2.65	3.25	3.85	4.62	5.93
O	4.33	5.31	6.69	7.87	8.50	12.00
P	1.57	1.57	1.07	1.00	1.00	1.57
Q	—	—	3.37	4.50	2.75	5.12
R	1.575	1.575	1.772	2.500	1.500	2.559
S	1.102	1.575	1.969	2.835	3.125	3.870
T	#8-32(6)	1/4-20(6)	5/16-18(8)	5/16-18(8)	5/16-18(8)	3/8-16(8)
U*	Ø.1583 / .1573 (2) ∇.250	Ø.2520 / .2510 (2) ∇.250	Ø.3145 / .3135 (2) ∇.375	Ø.3145 / .3135 (2) ∇.500	Ø.3145 / .3135 (2) ∇.500	Ø.3770 / .3760 (2) ∇.500
V	1.40	1.91	2.48	2.89	3.69	4.53

Dimensions in inches

*DOWEL HOLES

⊕	0.08 mm (M)
⊕	0.003 in (M)

MXB-P Rodless Belt Drive Actuator

tolomatic.com/CAD Download 3D CAD
Always use CAD solid model to determine critical dimensions



PROFILED RAIL BEARING OPTION DIMENSIONS

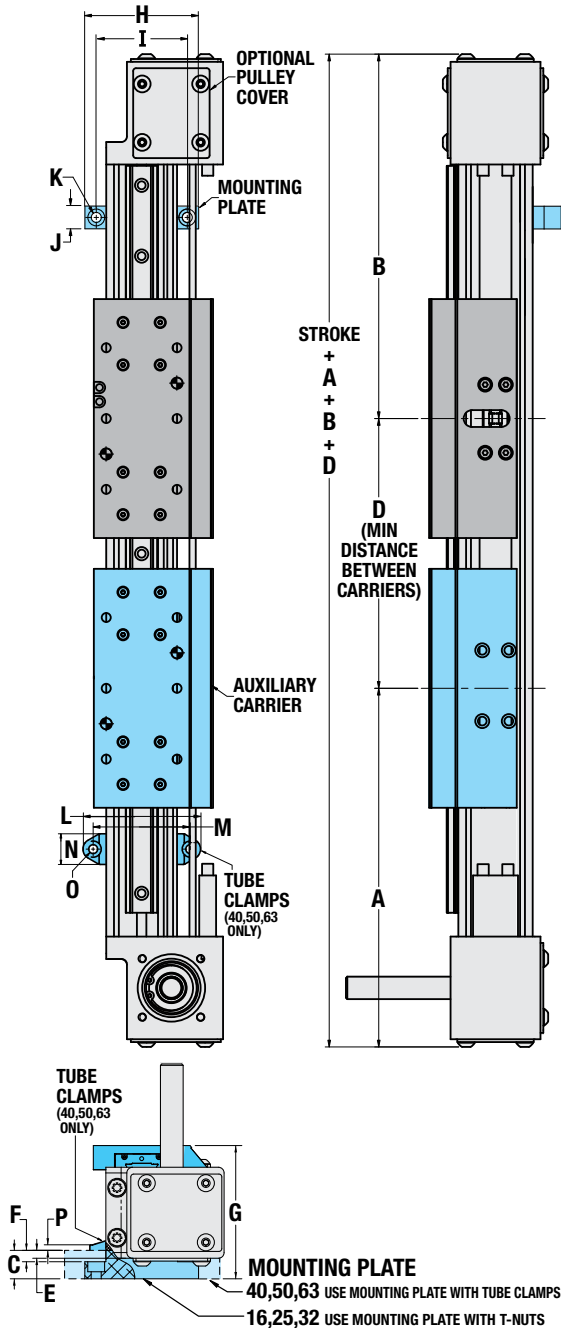

	MXB16	MXB25	MXB32	MXB40	MXB50	MXB63
A	135.3	173.9	187.8	216.6	224.7	275.1
B	119.0	139.3	154.7	192.7	205.0	262.1
AUXILIARY CARRIER						
D	127.0	152.4	177.0	215.9	216.4	330.2
MOUNTING PLATE						
C	15.9	15.9	19.1	25.4	31.8	25.4
E	7.2	4.4	7.2	9.3	9.8	5.6
F	6.4	6.4	7.6	—	—	—
G	61.9	74.4	96.5	114.8	151.4	165.4
H	60.0	63.5	86.4	127.0	142.2	203.2
I	44.5	50.8	69.9	112.0	127.0	177.8
J	25.4	25.4	25.4	20.1	20.1	25.4
K	Ø5.6 THRU └┘09.4 ▽5.6 (2)	Ø5.6 THRU └┘09.4 ▽5.6 (2)	Ø7.1 THRU └┘11.2 ▽7.1 (2)	Ø7.1 THRU (2)	Ø7.1 THRU (2)	Ø7.1 THRU (2)
TUBE CLAMPS						
L	—	—	—	96.8	111.5	150.6
M	—	—	—	82.8	97.5	131.8
N	—	—	—	14.0	14.0	19.1
O	—	—	—	7.1	7.1	10.7
P	—	—	—	3.8	3.8	6.1

Dimensions in millimeters

	MXB16	MXB25	MXB32	MXB40	MXB50	MXB63
A	5.33	6.85	7.39	8.53	8.85	10.83
B	4.69	5.49	6.09	7.59	8.07	10.33
AUXILIARY CARRIER						
D	5.00	6.00	7.00	8.50	8.60	13.00
MOUNTING PLATE						
C	0.63	0.63	0.75	1.00	1.25	1.00
E	0.28	0.17	0.29	0.37	0.39	0.22
F	0.25	0.25	0.30	—	—	—
G	2.44	2.93	3.80	4.52	5.96	6.51
H	2.36	2.50	3.40	5.00	5.60	8.00
I	1.75	2.00	2.75	4.41	5.00	7.00
J	1.00	1.00	1.00	0.79	0.79	1.00
K	Ø.22 THRU └┘0.37 ▽.22 (2)	Ø.22 THRU └┘0.37 ▽.22 (2)	Ø.28 THRU └┘0.44 ▽.28 (2)	Ø.28 THRU (2)	Ø.28 THRU (2)	Ø.28 THRU (2)
TUBE CLAMPS						
L	—	—	—	3.81	4.39	5.93
M	—	—	—	3.26	3.84	5.19
N	—	—	—	0.55	0.55	0.75
O	—	—	—	0.28	0.28	0.42
P	—	—	—	0.15	0.15	0.24

Dimensions in inches

MXB Rodless Belt Drive Actuator

tolomatic.com/CAD Download 3D CAD
Always use CAD solid model to determine
critical dimensions



DIRECT DRIVE MOTOR MOUNTING

MXB-U

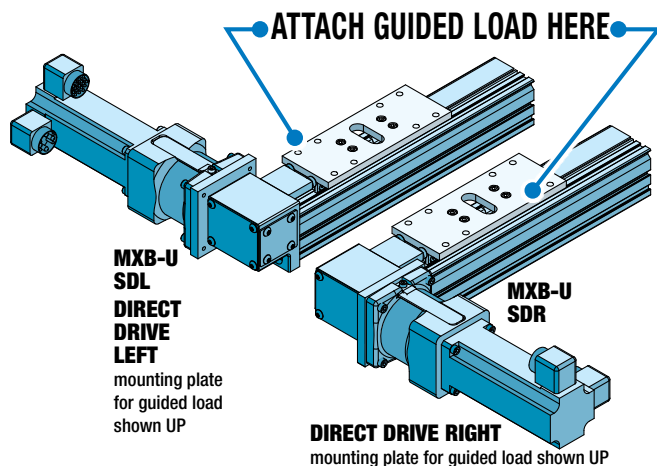

MXB-S

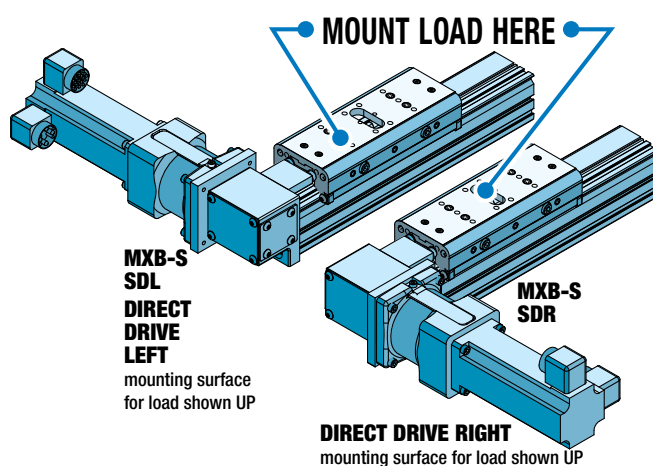

MXB-P

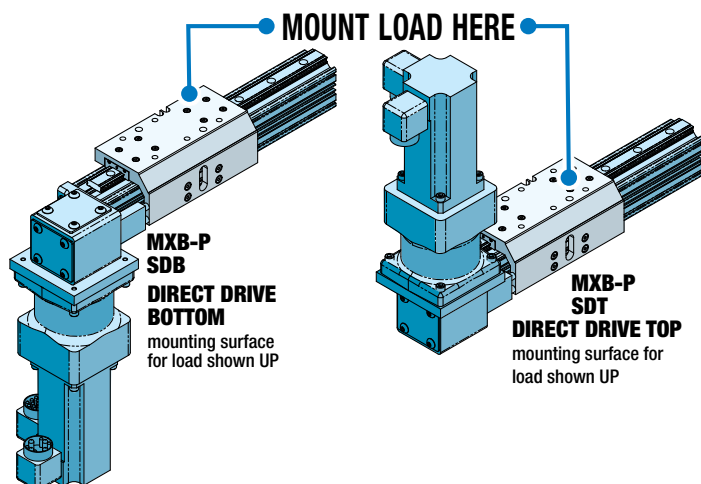

MOTOR MOUNTING

The MXB-P is unique among Tolomatic belt drive actuators. The mounting surface of the carrier is located 90° from the motion of the belt. The side opposite the belt is reserved for switch placement. The bottom of the actuator is reserved for mounting. If the motor is mounted in the SDT (direct drive top orientation), be sure the load mounted to the carrier does not interfere with the motor.



LARGE FRAME MOTORS AND SMALLER SIZE ACTUATORS: Cantilevered motors need to be supported if subjected to continuous rapid reversing duty and/or under dynamic conditions.

MXB Rodless Belt Drive Actuator

tolomatic.com/CAD Download 3D CAD
Always use CAD solid model to determine
critical dimensions



REDUCTION DRIVE MOTOR MOUNTING

MXB-U

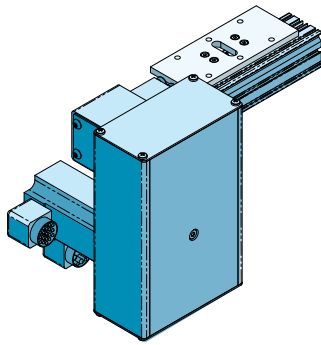

**REDUCTION DRIVE
BOTTOM LEFT (SDBL)**
mounting plate
for guided load shown UP

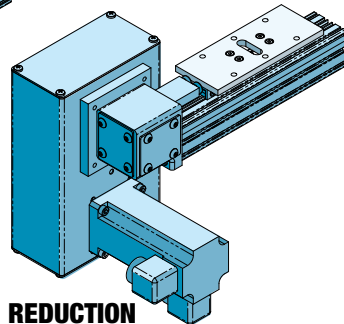

**REDUCTION
DRIVE
BOTTOM RIGHT (SDBR)**
mounting plate for
guided load shown UP

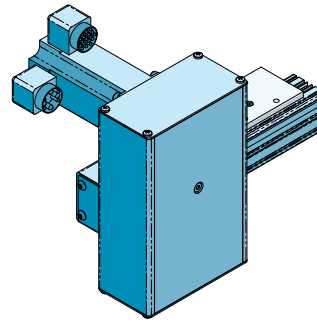

**REDUCTION DRIVE
TOP LEFT (SDTL)**
mounting plate for
guided load shown UP

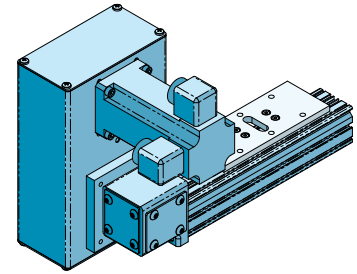

**REDUCTION DRIVE
TOP RIGHT (SDTR)**
mounting plate for
guided load shown UP

MXB-S

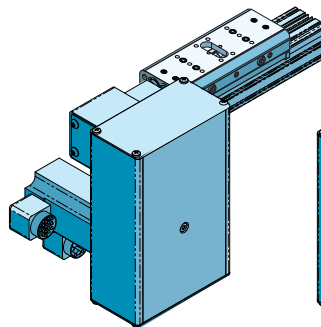

**REDUCTION DRIVE
BOTTOM LEFT (SDBL)**
mounting surface
for load shown UP

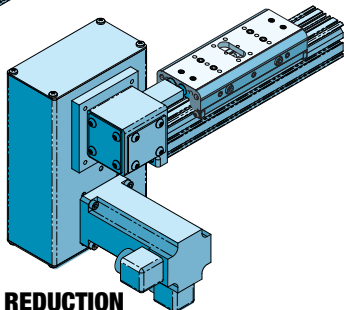

**REDUCTION
DRIVE
BOTTOM RIGHT (SDBR)**
mounting surface for load
shown UP

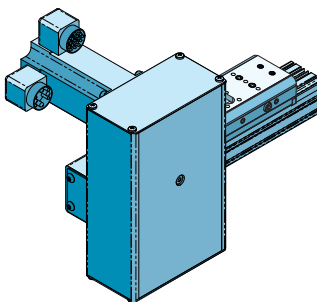

**REDUCTION DRIVE
TOP LEFT (SDTL)**
mounting surface
for load shown UP

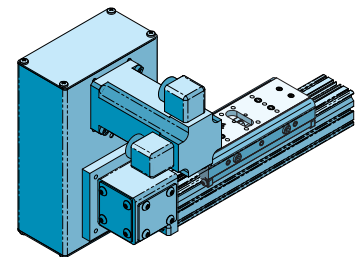

**REDUCTION DRIVE
TOP RIGHT (SDTR)**
mounting surface
for load shown UP

MXB-P

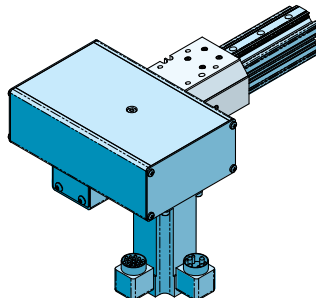

**REDUCTION DRIVE
RIGHT BOTTOM (SDBR)**
mounting surface
for load shown UP

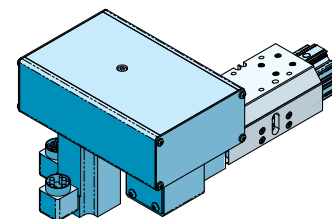

**REDUCTION DRIVE
LEFT BOTTOM (SDLB)**
mounting surface
for load shown UP

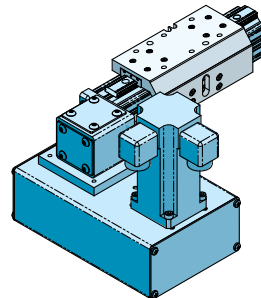

**REDUCTION DRIVE
RIGHT TOP (SDRT)**
mounting surface
for load shown UP

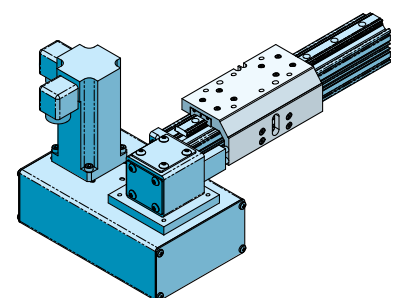

**REDUCTION DRIVE
LEFT TOP (SDLT)**
mounting surface
for load shown UP

 See tolomatic.com for 3D solid model(s) with motor mounting dimensions

MXB Rodless Belt Drive Actuator

SWITCHES SPECIFICATIONS



MX products offer a wide range of sensing choices. There are 12 switch choices: reed, solid state PNP (sourcing) or solid state NPN (sinking); in normally open or normally closed; with flying leads or quick-disconnect.

Commonly used for end-of-stroke positioning, these switches allow drop-in installation anywhere along the entire actuator length. The one-piece design includes the retained fastening hardware. The magnet and magnet hardware are located on the carrier. See the dimensional drawings on page **MXB_25** for details of magnet and switch locations. Switches and magnets can be installed in the field at any time.

Switches are used to send digital signals to PLC (programmable logic controller), TTL, CMOS circuit or other controller device. Switches contain reverse polarity protection. Solid state QD cables are shielded; shield should be terminated at flying lead end.

All switches are CE rated and are RoHS compliant. Switches feature bright red or yellow LED signal indicators; solid state switches also have green LED power indicators.



	Order Code	Lead	Switching Logic	Power LED	Signal LED	Operating Voltage	**Power Rating (Watts)	Switching Current (mA max.)	Current Consumption	Voltage Drop	Leakage Current	Temp. Range	Shock / Vibration
REED	R Y	5m	SPST Normally Open	—	Red	5 - 240 AC/DC	**10.0	100mA	—	3.0 V max.	—	14 to 158°F [-10 to 70°C]	50 G / 9 G
	R K	QD*											
	N Y	5m	SPST Normally Closed	—	Yellow	5 - 110 AC/DC							
	N K	QD*											
SOLID STATE	T Y	5m	PNP (Sourcing) Normally Open	Green	Yellow	10 - 30 VDC	**3.0	100mA	20 mA @ 24V	2.0 V max.	0.05 mA max.		
	T K	QD*											
	K Y	5m	NPN (Sinking) Normally Open	Green	Red								
	K K	QD*											
	P Y	5m	PNP (Sourcing) Normally Closed	Green	Yellow								
	P K	QD*											
	H Y	5m	NPN (Sinking) Normally Closed	Green	Red								
	H K	QD*											

*QD = Quick-disconnect

Enclosure classification IEC 529 IP67 (NEMA 6)

CABLES: Robotic grade, oil resistant polyurethane jacket, PVC insulation

▲WARNING:** Do not exceed power rating (Watt = Voltage x Amperage). Permanent damage to sensor will occur.

SWITCH INSTALLATION AND REPLACEMENT

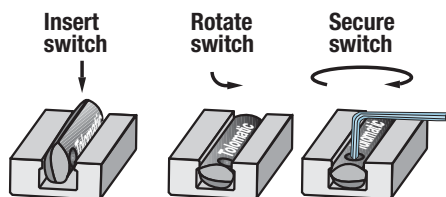

Place switch in side groove on tube at desired location with "Tolomatic" facing outward. While applying light pressure to the switch, rotate the switch halfway into the groove. Maintaining light pressure, rotate the switch in the opposite direction until it is fully inside the groove with "Tolomatic" visible. Re-position the switch to the exact location and lock the switch securely into place by tightening the screw on the switch.

MXB Rodless Belt Drive Actuator

SWITCHES

WIRING DIAGRAMS

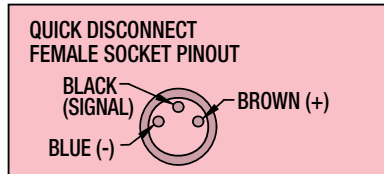
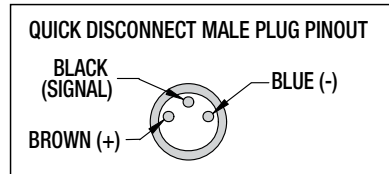
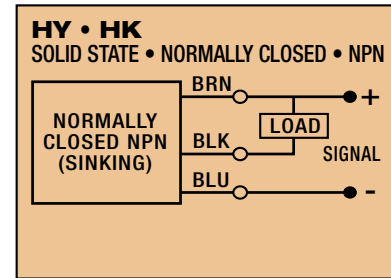
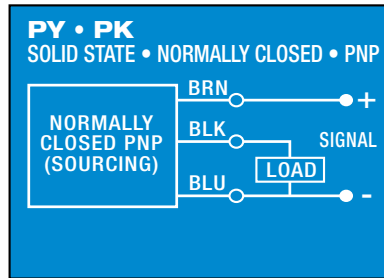
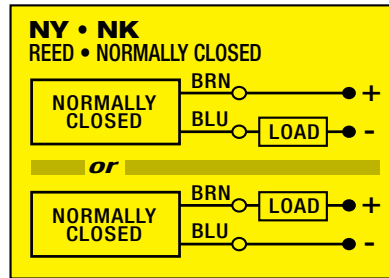
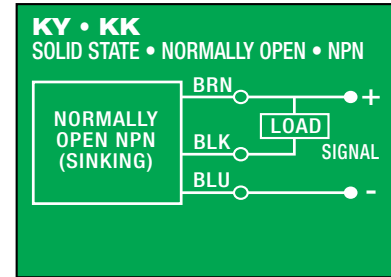
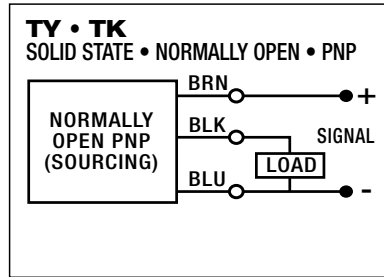
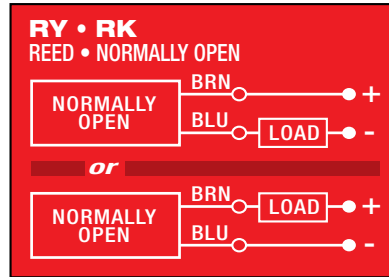

MOUNTING DIMENSIONS

MXB-U

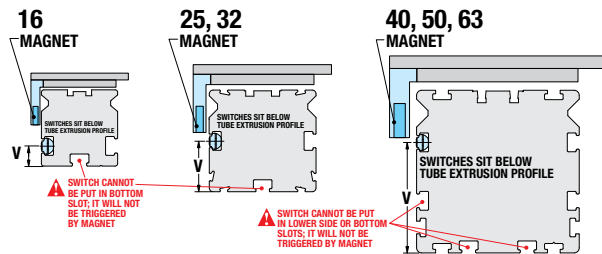

MXB-S

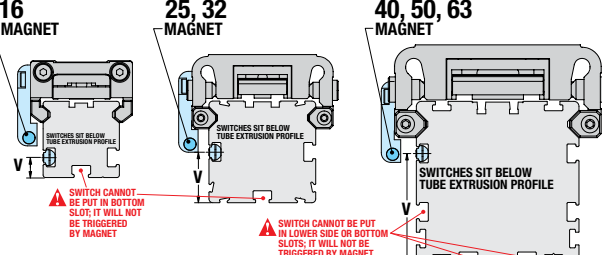

MXB-P

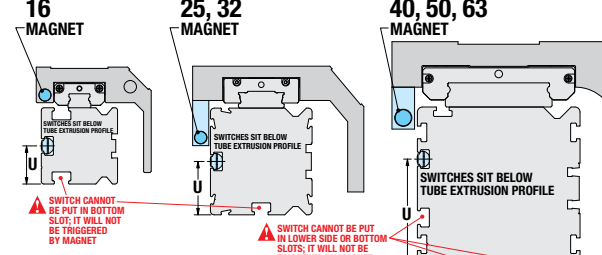

SWITCH DIMENSIONS

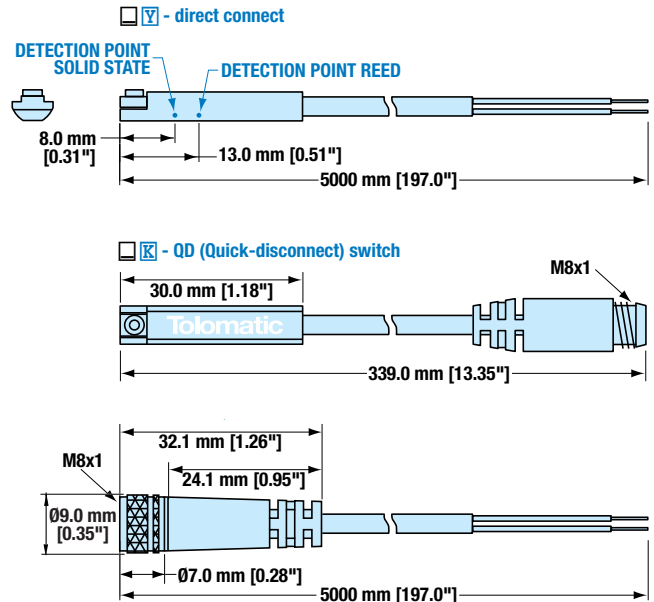

SWITCH MOUNTING

mm	MXB16	MXB25	MXB32	MXB40	MXB50	MXB63
U	15.0	21.0	27.7	43.5	51.4	62.0
V	7.9	20.0	27.0	43.5	51.4	62.0
in	MXB16	MXB25	MXB32	MXB40	MXB50	MXB63
U	0.59	0.83	1.09	1.71	2.02	2.44
V	0.31	0.79	1.06	1.71	2.02	2.44

NOTE: When ordering switches as a service part, Magnet Housing Kit (light blue in drawings) is required if actuator was not originally ordered with switches.

COMPILE APPLICATION REQUIREMENTS

ORIENTATION

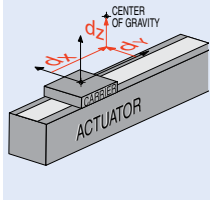
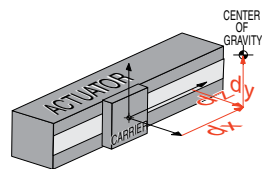
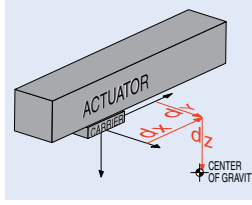
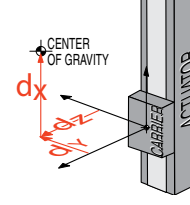
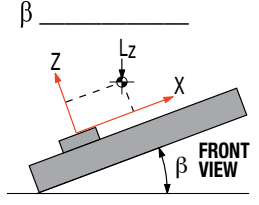
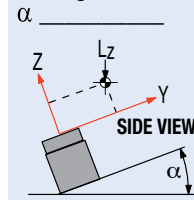
 Horizontal

 Side

 Horizontal Down

 Vertical

 Angled °

 Load attached to carrier OR Load supported by other mechanism

DISTANCE FROM CENTER OF CARRIER TO LOAD CENTER OF GRAVITY

 d_x _____
 d_y _____
 d_z _____

 inch
 (U.S. Standard)

 millimeter
 (Metric)

STROKE LENGTH

 inch (S) (K)
 (U.S. Standard)

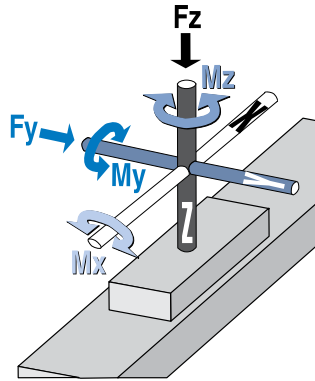
 millimeters
 (Metric)

BENDING MOMENTS APPLIED TO CARRIER

 in.-lbs.
 (U.S. Standard)

 N-m
 (Metric)

 M_x _____
 M_y _____
 M_z _____

PRECISION

Repeatability _____

 inch

 millimeters

NOTE: If load or force on carrier changes during cycle use the highest numbers for calculations

LOAD

 lb.
 (U.S. Standard)

 kg.
 (Metric)

THRUST REQUIRED

 lbf.
 (U.S. Standard)

 N
 (Metric)

 F_z _____
 F_y _____

OPERATING ENVIRONMENT

Temperature, Contamination, etc.

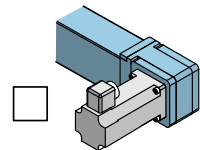
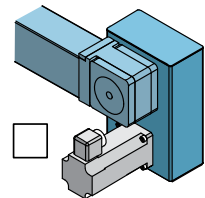
 Direct Drive

 Reduction Drive

MOVE PROFILE

Move Distance _____

 inch

 millimeters

Dwell Time After Move _____

 in/sec

 mm/sec

Max. Speed _____

 sec

MOVE TIME

 sec

NO. OF CYCLES

 per minute

 per hour

MOTION PROFILE

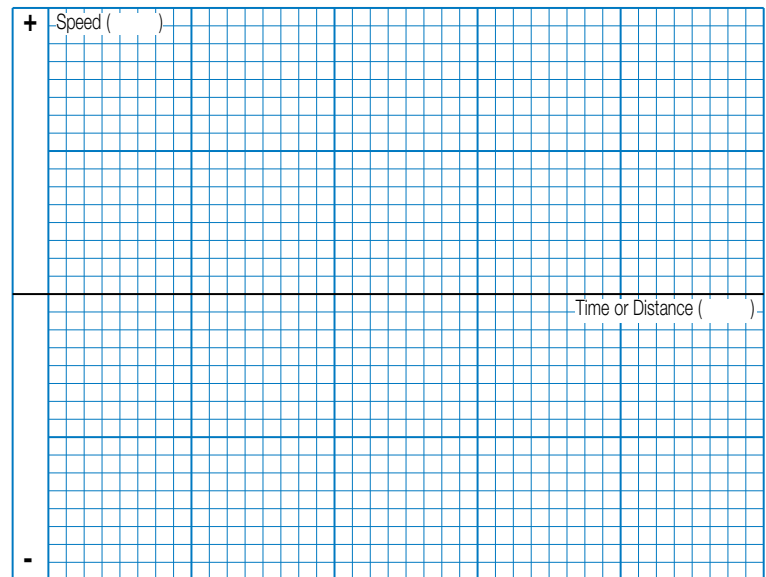

Graph your most demanding cycle, including accel/decel, velocity and dwell times. You may also want to indicate load variations and I/O changes during the cycle. Label axes with proper scale and units.

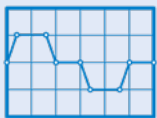

USE THE TOLOMATIC SIZING AND SELECTION SOFTWARE AVAILABLE ON-LINE AT

www.tolomatic.com OR... CALL TOLOMATIC 1-800-328-2174 with the above information. We will provide any assistance needed to determine the proper MX actuator for the job. FAX 1-763-478-8080

CONTACT INFORMATION

Name, Phone, Email
 Co. Name, Etc.

SELECTION GUIDELINES

The process of selecting a belt drive actuator for a given application can be complex. **It is highly recommended that you contact Tolomatic or a Tolomatic distributor for assistance in selecting the best actuator for your application.** The following overview of the selection guidelines are for educational purposes only.

1 CHOOSE ACTUATOR SIZE

Choose an actuator that has the thrust, speed and moment load capacity to move the load.

- A) For maximum thrust use the table below.
- B) Max. speed of MXB-U 200 in/sec (5 m/sec); Max. speed of MXB-S 100 in/sec (2.5 m/sec) Max. speed of MXB-P 150 in/sec (3.8 m/sec).
- C) For MXB-S moment and load capacities see tables on page [MXB_12](#). For MXB-P moment and load capacities see tables on page [MXB_13](#).

SIZE	MAXIMUM THRUST	
	lbf	N
16	38	169
25	151	672
32	209	930
40	250	1112
50	325	1446
63	418	1859

2 COMPARE LOAD TO MAXIMUM LOAD CAPACITIES

Calculate the application load (combination of load mass and forces applied to the carrier) and application bending moments (sum of all moments M_x , M_y , and M_z applied to the carrier). Be sure to evaluate the magnitude of dynamic inertia moments. When a rigidly attached

load mass is accelerated or decelerated, its inertia induces bending moments on the carrier. Careful attention to how the load is decelerated at the end of the stroke is required for improved actuator performance and application safety. If either load or any of the moments exceed figures indicated in the Moment and Load Capacity tables (page [MXB_12](#) & [13](#)) for the actuator consider:

- 1) A higher capacity carrier (i.e. **S** to **P**)
- 2) A larger actuator size
- 3) Auxiliary carrier
- 4) External guide system (if the load is externally supported and guided, consider using MXB-U)

3 CALCULATE LOAD FACTOR (LF)

For loads with a center of gravity offset from the carrier account for both applied (static) and dynamic loads. The load factor (LF) must not exceed the value of 1.

$$L_f = \frac{M_x}{M_{x_{max}}} + \frac{M_y}{M_{y_{max}}} + \frac{M_z}{M_{z_{max}}} + \frac{F_y}{F_{y_{max}}} + \frac{F_z}{F_{z_{max}}} \leq 1$$

If L_f does exceed the value of 1, consider the four choices listed in step #2.

4 ESTABLISH YOUR MOTION PROFILE AND CALCULATE ACCELERATION RATE

Using the application stroke length and maximum carrier velocity (or time to complete the linear motion), establish the motion profile. Select either triangular (accel-decel) or trapezoidal (accel-constant speed-decel) profile. Now calculate the maximum acceleration and deceleration rates of the move. Acceleration/deceleration should not exceed 1200 in/sec^2 (30.48 m/sec^2). Also, do not exceed safe rates of dynamic inertia moments determined in step #3.

5 SELECT MOTOR (GEARHEAD IF NECESSARY) AND DRIVE

To help select a motor and drive, use the sizing equations located in the Engineering Resources section of the Tolomatic Electric Products Catalog (#3600-4609) to calculate the application thrust and torque

requirements. Refer to Motor sections to determine the motor and drive.

6 DETERMINE MOUNTING PLATE REQUIREMENTS

- Consult the Mounting Plate Requirements graph for the model selected (page [MXB_11](#))
- Cross reference the application load and maximum distance between supports
- Select the appropriate number of mounting plates

7 CONSIDER OPTIONS

- Choose metric or inch (U.S. standard) load mounting. When ordering use **SIX** for inch and **SIM** for metric.
- Switches - Reed, Solid State PNP or NPN, all available normally open or normally closed
- **FL** Floating mount bracket - used when lack of parallelism occurs between the actuator and an externally guided and supported load (available for **S** Solid bearing style MXB actuators)

8 CONSIDER ORIENTATION

Belt drives used in vertical applications will not prevent a load falling in the event of a timing belt failure. A secondary safety measure is recommended if a MXB is used in a safety critical vertical application.

S SOLID BEARING 2:1 RULE

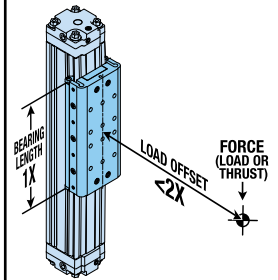

For applications using **S** solid bearings, binding or interrupted motion may occur if the load offset is equal to or greater than twice the bearing length (1X). *LOAD OFFSET* is defined as: the distance from the applied force (or the load center of gravity) to the centerline of the carrier.

If the load offset cannot be changed consider:

- 1.) Higher capacity bearing style, i.e. **S** to **P**
- 2.) Larger actuator size
- 3.) Auxiliary carrier
- 4.) Add external guides

SPEED FACTOR

FOR APPLICATIONS WITH HIGH SPEED OR SIGNIFICANT SHOCK AND VIBRATION: Calculated values of loads and bending moments must be increased by speed factor from the graph below to obtain full rated life of profiled rail bearing system.

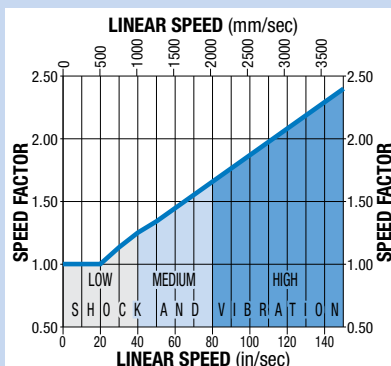

MXB Rodless Belt Drive Actuators

SERVICE PARTS ORDERING

SWITCHES

Switches for MXB include retained mounting hardware and are the same for all actuator sizes and bearing styles

Code	Lead	Normally	Sensor Type
R Y	5m (197 in)	Open	Reed
R K	Quick-disconnect		
N Y	5m (197 in)	Closed	Reed
N K	Quick-disconnect		
T Y	5m (197 in)	Open	Solid State PNP
T K	Quick-disconnect		
K Y	5m (197 in)	Open	Solid State NPN
K K	Quick-disconnect		
P Y	5m (197 in)	Closed	Solid State PNP
P K	Quick-disconnect		
H Y	5m (197 in)	Closed	Solid State NPN
H K	Quick-disconnect		

NOTE: All switch kits include retained hardware. Quick-disconnect kits include female connector

⚠ NOTE: When ordering switches as service part, Magnet Housing Kit is required if actuator was not originally ordered with switches

To order switch kit use configuration code for switch preceded by SW and actuator code.

EXAMPLE: **S****W****M****X****B****2****5****K****K**

KIT
ACTUATOR
SIZE
SWITCH CODE

The example is for Solid State NPN, Normally Open Switch with Quick-disconnect couplers. Each switch kit is complete with Bracket, Set Screw, Switch and mating QD cable. Note that the bracket/switch size is common and may be used on any size MXB.

[Check out our MX--S carrier adjustment video on the web](https://youtu.be/LVWPg2qfy0A)
<https://youtu.be/LVWPg2qfy0A>

Select a complete system from tolomatic or add any motion system to Tolomatic's actuators



YOUR MOTOR HERE® MADE-TO-ORDER MOTOR MOUNTS.

- Tolomatic will provide a motor-specific interface for nearly any motor.

Visit www.tolomatic.com/ymh to find your motor/actuator match!

in Partnership with these manufacturers and others for more options



JVL
www.jvl.dk

Nidec
CONTROL TECHNIQUES

MXB Rodless Belt Drive Actuators

tolomatic.com/ask
 Technical support
 before and after
 purchase



ORDERING

MODEL SELECTION (MUST BE IN THIS ORDER)

MXB 40 P BWS30 SM2007-02

OPTIONS (IN ANY ORDER)

SDB DC215-9 MP8 HC2 TK2

MODEL
 MXB MX Rodless Belt Drive Actuators

SERIES
 16 Series actuator 40 Series actuator
 25 Series actuator 50 Series actuator
 32 Series actuator 63 Series actuator

BEARING
 U Unguided Carrier
 S Solid Bearing Carrier
 P Profiled Rail Bearing Carrier

BELT MATERIAL AND WIDTH
 BWS10 10 mm Urethane Steel (MXB16)
 BWS18 18 mm Urethane Steel (MXB25)
 BWS25 25 mm Urethane Steel (MXB32)
 BWS30 30 mm Urethane Steel (MXB40)
 BWS40 40 mm Urethane Steel (MXB50)
 BWS50 50 mm Urethane Steel (MXB63)

STROKE LENGTH & MOUNTING TYPE
 SK _____ Stroke, enter desired stroke length in **inches**
 SM† _____ Stroke, enter desired stroke length in **millimeters**
 GPB Blank Plate (MXB-U only)
 NO MOUNTING HOLES allowing user to drill and tap as needed
NOTE: Actuator mounting threads and mounting fasteners will be either inch or metric, depending on how stroke length is indicated
SK=inch mounting
SM= metric mounting

† The metric version provides metric tapped holes for mounting of the load to the carrier and of the actuator to mounting surfaces

NOTE: Brakes mounted on reduction drives (especially in vertically positioned actuators) will not prevent back driving of the screw and the load falling under gravity in the event of a timing belt failure. An inline motor mount with a fail-safe brake mounted directly to the actuator shaft or a special geared or thru-shaft reduction drive construction should be considered if a brake is required in a safety critical application. Contact Tolomatic for alternative reduction drive brake mounting options.

Gearheads may be used with reduction drives. However, the torque on the belt and internal reduction drive components must remain below the capabilities of the assembly to prevent belt slipping or premature failure. Contact Tolomatic for additional information if required.

U & S MOTOR MOUNTING/REDUCTION
 (must choose one)
 SDL, SDLD* Direct Drive on Left
 SDR, SDRD* Direct Drive on Right
▲ A motor size and code must be selected when specifying a 3:1 reduction.
 (2:1 reduction on MXB16)
 SDTL, SDTLD* 3:1 Reduction on Top Left
 SDTR, SDTRD* 3:1 Reduction on Top Right
 SDBL, SDBLD* 3:1 Reduction on Left Bottom
 SDBR, SDBRD* 3:1 Reduction on Right Bottom
***For Dual Stub Shaft Option**

P MOTOR MOUNTING / REDUCTION
 (must choose one)
 SDT, SDTD* Direct Drive on Top
 SDB, SDBD* Direct Drive on Bottom
▲ A motor size and code must be selected when specifying a 3:1 reduction.
 (2:1 reduction on MXB16)
 SDLT, SDLTD* 3:1 Reduction on Left Top
 SDRT, SDRTD* 3:1 Reduction on Right Top
 SDLB, SDLBD* 3:1 Reduction on Left Bottom
 SDRB, SDRBD* 3:1 Reduction on Right Bottom
***For Dual Stub Shaft Option**

AUXILIARY CARRIER
 DC _____ Auxiliary Carrier, (MXB-P only) enter center-to-center spacing desired in **inches** (SK) or **millimeters** (SM)
 (Same unit of measure as stroke length is required)
▲ Center-to-center spacing between carriers adds to overall length of the actuator, this distance will not be subtracted from stroke length specified in the previous step

HEAD COVER PLATES
 HC2 Head Cover Plates

MOUNTING
 MP_ Mounting Plates, & quantity
 TC_ Tube Clamps, & quantity
 NOTE: The MXB requires Mounting Plates to allow clearance for motor when mounted flush to surface.
 16,25,32 sizes use T-Nuts with Mounting Plates.
 40,50,63 sizes use Tube Clamps with Mounting Plates.

P CARRIER ORIENTATION
 BIR Mirrored Carrier Design

MOTOR / DRIVE / CONTROLLER / PLANETARY GEARBOX
▲ Reference the ordering pages in Tolomatic Electric Product Brochures Stepper Products Brochure #3600-4160 & Planetary Gearbox Doc. #3600-4161

		SWITCHES				QUANTITY	LEAD LENGTH
TYPE	LOGIC	NORMALLY	QUICK-DISCONNECT	CODE			
REED	SPST	Open	no	RY	After code enter quantity desired	5 meters (16.4 feet)	
			QD	RK			
SOLID STATE	PNP	Open	no	TY			
			QD	TK			
	NPN	Open	no	KY			
			QD	KK			
	PNP	Closed	no	PY			
			QD	PK			
NPN	Closed	no	HY				
		QD	HK				

▲ Not all codes listed are compatible with all options.

Call Tolomatic 1-800-328-2174 to determine available options and accessories based on your application requirements.

The Tolomatic Difference Expect More From the Industry Leader:



INNOVATIVE PRODUCTS

Solutions with Endurance TechnologySM for challenging applications.



FAST DELIVERY

Built-to-order with configurable stroke lengths and flexible mounting options.

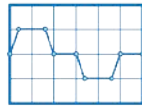

ACTUATOR SIZING

Size and select electric actuators with our online software.



YOUR MOTOR HERE[®]

Match your motor to compatible mounting plates with Tolomatic actuators.



CAD LIBRARY

Download 2D or 3D CAD files for Tolomatic products.



TECHNICAL SUPPORT

Get a question answered or request a virtual design consultation with one of our engineers.

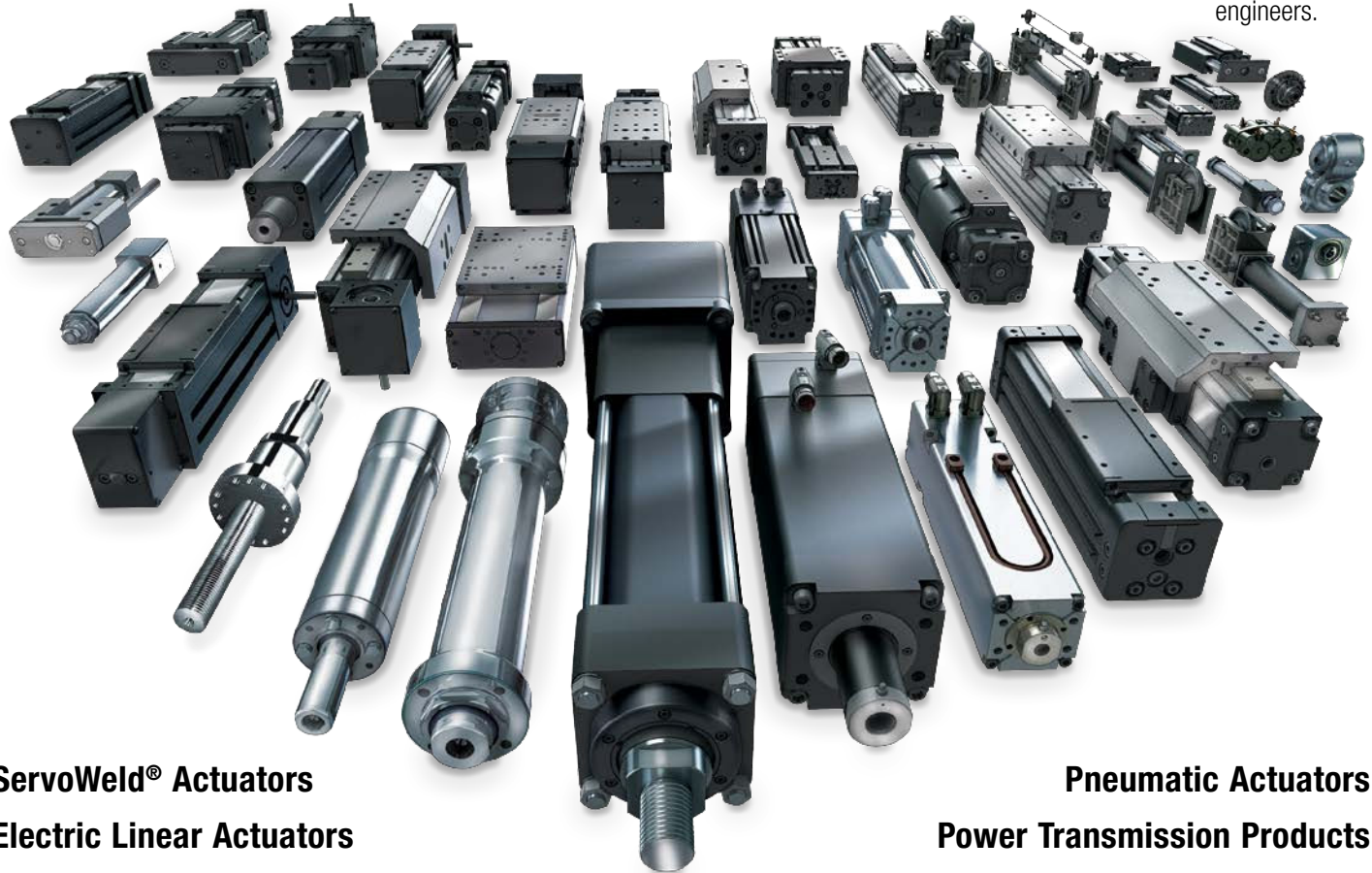

ServoWeld[®] Actuators
Electric Linear Actuators

Pneumatic Actuators
Power Transmission Products



MADE IN U.S.A.

Tolomatic[™]

EXCELLENCE *IN* MOTION

COMPANY WITH
QUALITY SYSTEM
CERTIFIED BY DNV
= ISO 9001 =
Certified site: Hamel, MN

USA - Headquarters

Tolomatic Inc.

3800 County Road 116
Hamel, MN 55340, USA

Phone: (763) 478-8000

Toll-Free: **1-800-328-2174**

sales@tolomatic.com

www.tolomatic.com

MEXICO

Centro de Servicio

Parque Tecnológico Innovación
Int. 23, Lateral Estatal 431,
Santiago de Querétaro,

El Marqués, México, C.P. 76246

Phone: +1 (763) 478-8000

help@tolomatic.com

EUROPE

Tolomatic Europe GmbH

Elisabethenstr. 20
65428 Rüsselsheim
Germany

Phone: +49 6142 17604-0

help@tolomatic.eu

www.tolomatic.com/de-de

CHINA

Tolomatic Automation Products (Suzhou) Co. Ltd.

No. 60 Chuangye Street, Building 2
Huqiu District, SND Suzhou
Jiangsu 215011 - P.R. China

Phone: +86 (512) 6750-8506

Tolomatic_China@tolomatic.com

All brand and product names are trademarks or registered trademarks of their respective owners. Information in this document is believed accurate at time of printing. However, Tolomatic assumes no responsibility for its use or for any errors

that may appear in this document. Tolomatic reserves the right to change the design or operation of the equipment described herein and any associated motion products without notice. Information in this document is subject to change without notice.

Visit www.tolomatic.com for the most up-to-date technical information