

Incremental encoders

Standard sine wave output, with reference signal, optical	5804 / 5824 (shaft / hollow shaft)	SinCos
---	---	---------------



The incremental encoders type 5804 / 5824 offer a SinCos interface.

They are ideal for use in drive engineering.

These encoders are used preferably in applications for which a standard SinCos interface is sufficient.



High rotational speed	Temperature range	High protection level	High shaft load capacity	Shock / vibration resistant	Magnetic field proof	Short-circuit proof	Optical sensor

High performance

- High resolution up to 5000 pulses per revolution.
- Maximum speed up to 12000 revolutions per minute.
- High IP protection up to max. IP66.

Adaptable

- Shaft or hollow shaft version.
- With cable or connector.

Order code	8.5804	. XXXXX . XXXX					
Shaft version	Type	<table border="1" style="font-size: small;"> <tr> <td style="text-align: center;">a</td> <td style="text-align: center;">b</td> <td style="text-align: center;">c</td> <td style="text-align: center;">d</td> <td style="text-align: center;">e</td> </tr> </table>	a	b	c	d	e
a	b	c	d	e			

a Flange
 1 = clamping flange ø 58 mm [2.28"]
 2 = synchro flange ø 58 mm [2.28"]

b Shaft (ø x L), with flat
 1 = ø 6 x 10 mm [0.24 x 0.39"]
 2 = ø 10 x 20 mm [0.39 x 0.79"]

c Output circuit / supply voltage
 1 = SinCos, 1 Vpp (with inverted signal) / 5 V DC
 2 = SinCos, 1 Vpp (with inverted signal) / 10 ... 30 V DC

d Type of connection
 1 = axial cable, 1 m [3.28'] TPE
 A = axial cable, special length TPE *)
 2 = radial cable, 1 m [3.28'] TPE
 B = radial cable, special length TPE *)
 3 = axial M23 connector, 12-pin
 5 = radial M23 connector, 12-pin

e Pulse rate
 512, 1000, 1024, 1200, 1250,
 1500, 2000, 2048, 2500, 3000,
 3600, 4000, 4096, 5000
 (e.g. 512 pulses => 0512)

Optional on request
 - other pulse rates

*) Available special lengths (connection types A, B):
 2, 3, 5, 8, 10, 15 m [5.56, 9.84, 16.40, 26.25, 32.80, 49.21']
 order code expansion .XXXX = length in dm
 ex.: 8.5804.111A.0512.0030 (for cable length 3 m)

Incremental encoders

Standard sine wave output, with reference signal, optical	5804 / 5824 (shaft / hollow shaft)	SinCos
--	---	---------------

Order code	8.5824	.XXXX	.XXXX
Hollow shaft	Type	a b c d	e

<p>a Flange</p> <p>1 = with hollow shaft and spring element, short 2 = with blind hollow shaft and spring element, short 3 = with hollow shaft and stator coupling, ø 65 mm [2.56"] 4 = with blind hollow shaft and stator coupling, ø 65 mm [2.56"]</p> <p>b Hollow shaft <i>(insertion depth blind hollow shaft with flange 2 and 4 max. 30 mm [1.18"])</i></p> <p>1 = ø 6 mm [0.24"], IP40 2 = ø 6 mm [0.24"], IP66 3 = ø 8 mm [0.32"], IP40 4 = ø 8 mm [0.32"], IP66 5 = ø 10 mm [0.39"], IP40 6 = ø 10 mm [0.39"], IP66 7 = ø 12 mm [0.47"], IP40 8 = ø 12 mm [0.47"], IP66</p>	<p>c Output circuit / supply voltage</p> <p>1 = SinCos, 1 Vpp (with inverted signal) / 5 V DC 2 = SinCos, 1 Vpp (with inverted signal) / 10 ... 30 V DC</p> <p>d Type of connection</p> <p>1 = radial cable, 1 m [3.28'] TPE A = radial cable, special length TPE *) 2 = radial M23 connector, 12-pin</p> <p>*) Available special lengths (connection types A): 2, 3, 5, 8, 10, 15 m [5.56, 9.84, 16.40, 26.25, 32.80, 49.21'] order code expansion .XXXX = length in dm ex.: 8.5824.111A.0512.0030 (for cable length 3 m)</p>	<p>e Pulse rate</p> <p>512, 1000, 1024, 1200, 1250, 1500, 2000, 2048, 2500, 3000, 3600, 4000, 4096, 5000 (e.g. 512 pulses => 0512)</p> <p><i>Optional on request</i> - other pulse rates</p>
---	--	---

Mounting accessory for shaft encoders		Order no.
Coupling	bellows coupling ø 19 mm [0.75"] for shaft 6 mm [0.24"]	8.0000.1102.0606
	bellows coupling ø 19 mm [0.75"] for shaft 10 mm [0.39"]	8.0000.1102.1010

Mounting accessory for hollow shaft encoders		Dimensions in mm [inch]	Order no.
Torque pin, ø 4 mm	with fixing thread		8.0010.4700.0000
for flange with spring element (flange type 1 + 2)			

Stator coupling, ø 63 mm [2.48"]		8.0010.4D00.0000
---	--	-------------------------

Cables and connectors		Order no.
Preassembled cables	M23 female connector with coupling nut, 12-pin, cw single ended 2 m [6.56'] PVC cable	8.0000.6E01.0002
Connectors	M23 female connector with coupling nut, 12-pin, cw	8.0000.5012.0000

Further Kübler accessories can be found at: kuebler.com/accessories
 Further Kübler cables and connectors can be found at: kuebler.com/connection-technology

Incremental encoders

Standard sine wave output, with reference signal, optical	5804 / 5824 (shaft / hollow shaft)	SinCos
---	---	---------------

Technical data

Mechanical characteristics		
Maximum Speed	shaft IP65	12000 min ⁻¹
	hollow shaft IP40	12000 min ⁻¹
	hollow shaft IP66 ¹⁾	6000 min ⁻¹
Mass moment of inertia	shaft	approx. 1.8 x 10 ⁻⁶ kgm ²
	hollow shaft	approx. 6.0 x 10 ⁻⁶ kgm ²
Starting torque – at 20 °C [68 °F]	shaft IP65 / hollow shaft IP40	< 0.01 Nm
	hollow shaft IP66	< 0.05 Nm
Load capacity of shaft	radial	80 N
	axial	40 N
Weight		approx. 0.4 kg [14.11 oz]
Protection acc. to EN 60529	shaft	IP65
	hollow shaft without seal	IP40
	hollow shaft with seal	IP66
Working temperature range	shaft IP65 / hollow shaft IP40	-20 °C ... +85 °C [-4 °F ... +185 °F] ²⁾
	hollow shaft IP66	-20 °C ... +80 °C [-4 °F ... +176 °F] ²⁾
Material	shaft	stainless steel H7
Shock resistance acc. EN 60068-2-27		1000 m/s ² , 6 ms
Vibration resistance acc. to EN 60068-2-6		100 m/s ² , 10 ... 2000 Hz

Electrical characteristics		
Output circuit	SinCos, U = 1 Vpp	SinCos, U = 1 Vpp
Supply voltage	5 V DC (±5 %)	10 ... 30 V DC
Power consumption with inverted signal (no load)	typ. 65 mA	typ. 65 mA
	max. 110 mA	max. 110 mA
-3 dB frequency	≤ 180 kHz	≤ 180 kHz
Signal level	channels A/B	1 Vpp (±20 %)
	channel 0	0.1 ... 1.2 V
		0.1 ... 1.2 V
Short circuit proof outputs ³⁾	yes	yes
Reverse polarity protection of the supply voltage	no	yes

Approvals	
UL compliant in accordance with	File no. E224618
CE compliant in accordance with	
EMC Directive	2014/30/EU
RoHS Directive	2011/65/EU

Terminal assignment

Output circuit	Type of connection	Cable (isolate unused cores individually before initial start-up)												
1, 2	5804: 1, 2, A, B	Signal:	0 V	+V	0Vsens ⁵⁾	+Vsens ⁵⁾	A	\bar{A}	B	\bar{B}	0	$\bar{0}$	\perp	
	5824: 1, A	Core color:	WH 0.5 mm ²	BN 0.5 mm ²	WH	BN	GN	YE	GY	PK	BU	RD	shield	
Output circuit	Type of connection	M23 connector, 12-pin												
1, 2	5804: 3, 5	Signal:	0 V	+V	0Vsens ⁵⁾	+Vsens ⁵⁾	A	\bar{A}	B	\bar{B}	0	$\bar{0}$	\perp	
	5824: 2	Pin:	10	12	11	2	5	6	8	1	3	4	PH ⁴⁾	

Using RS422 outputs and long cable distances, a wave impedance has to be applied at each cable end.

- +V: Supply voltage encoder +V DC
- 0 V: Supply voltage encoder ground GND (0 V)
- 0 Vsens / +Vsens: Using the sensor outputs of the encoder, the voltage present can be measured and if necessary increased accordingly.
- A, \bar{A} : Cosine signal
- B, \bar{B} : Sine signal
- 0, $\bar{0}$: Reference signal
- PH \perp : Plug connector housing (shield)

Top view of mating side, male contact base

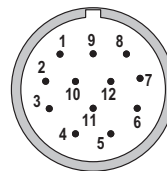

M23 connector, 12-pin

1) For continuous operation max. 3000 min⁻¹, ventilated.
 2) 70 °C [158 °F] for cable version.
 3) If supply voltage correctly applied.
 4) PH = shield is attached to connector housing.
 5) The sensor cables are connected to the supply voltage internally. If long feeder cables are involved they can be used to adjust or control the voltage at the encoder.

Incremental encoders

Standard sine wave output, with reference signal, optical	5804 / 5824 (shaft / hollow shaft)	SinCos
--	---	---------------

**Clamping flange, ø 58 [2.28]
Flange type 1**

1 3 x M3, 5 [0.2] deep

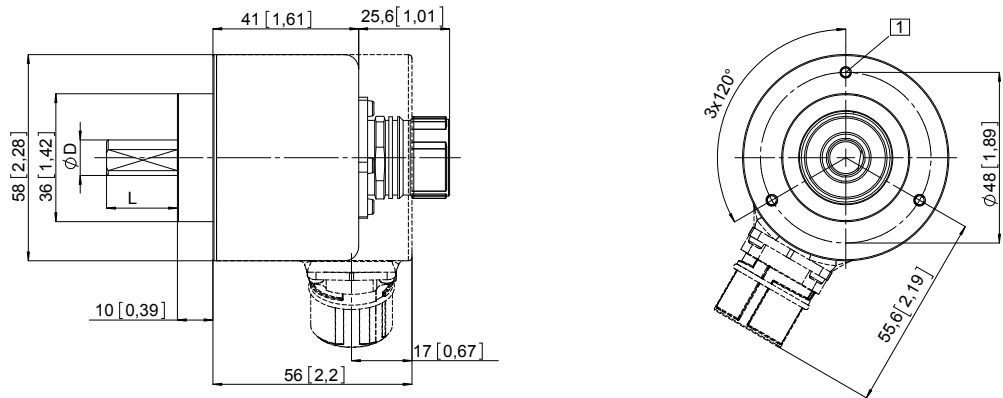

D	Fit	L
6 [0.24]	h7	10 [0.39]
10 [0.39]	f7	20 [0.79]

**Synchro flange, ø 58 [2.28]
Flange type 2**

1 3 x M4, 5 [0.2] deep

R_{min}:
- securely installed: 55 [2.17]
- flexibly installed: 70 [2.76]

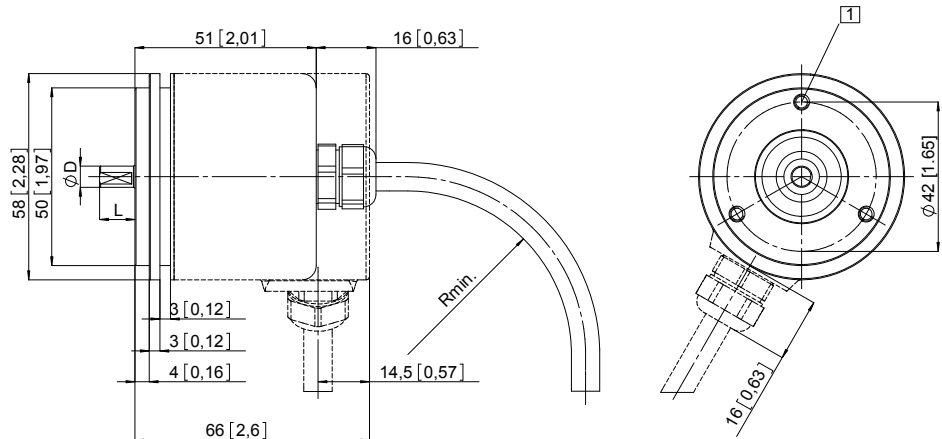

D	Fit	L
6 [0.24]	h7	10 [0.39]
10 [0.39]	f7	20 [0.79]

Incremental encoders

Standard sine wave output, with reference signal, optical	5804 / 5824 (shaft / hollow shaft)	SinCos
---	---	---------------

Dimensions hollow shaft version

Dimensions in mm [inch]

Flange with spring element, short Flange type 1 and 2

- 1 3 x M3, 5 [0.2] deep
- 2 Recommended torque for the clamping ring 0.6 Nm

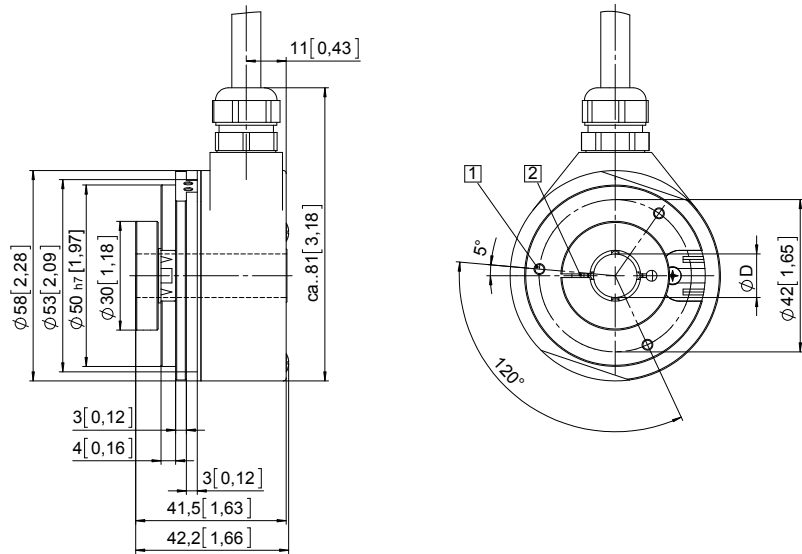

D	Fit
6 [0.24]	H7
8 [0.32]	H7
10 [0.39]	H7
12 [0.47]	H7

Insertion depth blind hollow shaft with flange 2:
max. 30 mm [1.18"]

Flange with stator coupling, ø 65 [2.56] Flange type 3 and 4

- 1 Recommended torque for the clamping ring 0.6 Nm

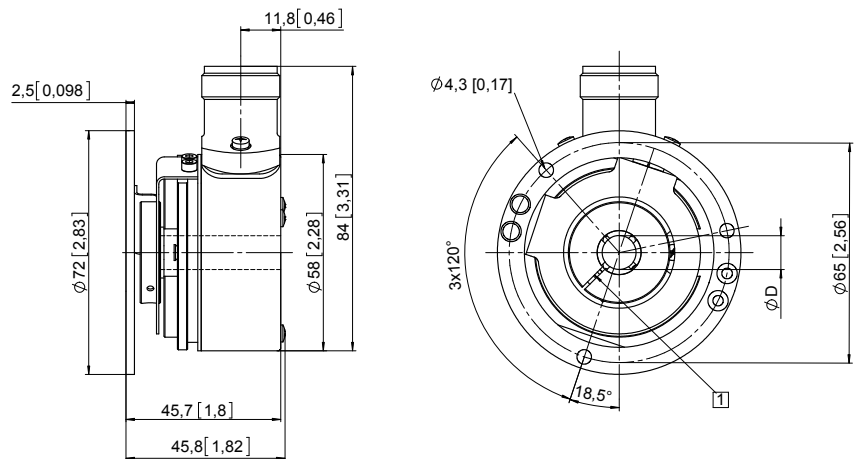

D	Fit
6 [0.24]	H7
8 [0.32]	H7
10 [0.39]	H7
12 [0.47]	H7

Min. insertion depth = 1.5 x D
Insertion depth blind hollow shaft with flange 4:
max. 30 mm [1.18"]