

Incremental encoders

Standard sine wave output, SIL3/PLe, optical	Sendix 5814FS3 / 5834FS3 (shaft / hollow shaft)	SinCos
--	--	---------------



The incremental encoders 5814FS3 and 5834FS3 of the Sendix family are suited for use in safety-related applications up to SIL3 according to EN 61800-5-2 or PLe to EN ISO 13849-1.

These encoders are particularly suited for applications in the field of safe drive technology.



Safety-Lock™



High rotational speed



Temperature range
-40°...+90°C



High protection level
IP



High shaft load capacity



Shock / vibration resistant



Magnetic field proof



Reverse polarity protection

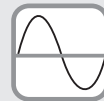

SinCos



Optical sensor

Functional Safety

- Encoder with individual certificate from TÜV.
- Suitable for applications up to SIL3 acc. to EN 61800-5-2.
- Suitable for applications up to PLe acc. to EN ISO 13849-1.
- With incremental SinCos tracks.
- Certified mechanical mounting + electronic.

Flexible

- Shaft and hollow shaft versions.
- Cable and connector variants.
- Various mounting options available.

Order code 8.5814FS3 . XXXX . XXXX
Shaft version Type a b c d e

a Flange

- 1 = clamping flange, IP65, ø 58 mm [2.28"]
- 3 = clamping flange, IP67, ø 58 mm [2.28"]

b Shaft (ø x L)

- 2 = 10 x 20 mm [0.39 x 0.79"], with flat
- A = 10 x 20 mm [0.39 x 0.79"], with feather key

c Output circuit / supply voltage

- 1 = SinCos / 5 V DC
- 2 = SinCos / 10 ... 30 V DC

d Type of connection

- 1 = axial cable, 1 m [3.28'] PVC
- A = axial cable, special length PVC *)
- 2 = radial cable, 1 m [3.28'] PVC
- B = radial cable, special length PVC *)
- 3 = axial M23 connector, 12-pin
- 4 = radial M23 connector, 12-pin
- 5 = axial M12 connector, 8-pin
- 6 = radial M12 connector, 8-pin

*) Available special lengths (connection types A, B):
 2, 3, 5, 8, 10, 15 m [6.56, 9.84, 16.40, 26.25, 32.80, 49.21']
 order code expansion .XXXX = length in dm
 ex.: 8.5814FS3.122A.2048.0030 (for cable length 3 m)

e Pulse rate

1024, 2048

Optional on request

- Ex 2/22 ¹⁾
- surface protection salt spray

1) For the cable connection type, cable material PUR.

Incremental encoders

Standard sine wave output, SIL3/PLe, optical	Sendix 5814FS3 / 5834FS3 (shaft / hollow shaft)	SinCos
---	--	---------------

Order code Hollow shaft	8.5834FS3 Type	.XXXXX a b c d e	.XXXX e
a Flange 9 = with torque stop FS, flexible, IP65 J = with torque stop FS, flexible, IP67 A = with torque stop FS, rigid, IP65 (incl. torque pin FS) K = with torque stop FS, rigid, IP67 (incl. torque pin FS) B = with stator coupling FS, ø 63 mm [2.48"], IP65 L = with stator coupling FS, ø 63 mm [2.48"], IP67	b Through hollow shaft 3 = ø 10 mm [0.39"] 4 = ø 12 mm [0.47"] 5 = ø 14 mm [0.55"] <i>Tapered shaft</i> K = ø 10 mm [0.39"]	c Output circuit / supply voltage 1 = SinCos / 5 V DC 2 = SinCos / 10 ... 30 V DC	d Type of connection 2 = radial cable, 1 m [3.28'] PVC B = radial cable, special length PVC *) E = tangential cable, 1 m [3.28'] PVC F = tangential cable, special length PVC *) 4 = radial M23 connector, 12-pin 6 = radial M12 connector, 8-pin *) Available special lengths (connection types B, F): 2, 3, 5, 8, 10, 15 m [6.56, 9.84, 16.40, 26.25, 32.80, 49.21'] order code expansion .XXXX = length in dm ex.: 8.5834FS3.B42B.2048.0030 (for cable length 3 m)
			e Pulse rate 1024, 2048 <i>Optional on request</i> - Ex 2/22 (not for connection type E + F) ¹⁾²⁾ - surface protection salt spray ²⁾

Accessories		Order no.
EMC shield terminal	for top-hat rail mounting	8.0000.4G06.0312
Screw retention	Loctite 243, 5 ml	8.0000.4G05.0000
Bellows coupling, safety-oriented	You will find an overview of our couplings for Sendix shaft encoders under kuebler.com/accessories .	
Safety modules Safety-M compact	You will find an overview of our systems and components for Functional Safety and the corresponding software under kuebler.com/safety .	

Cables and connectors		Order no.
Preassembled cables	M12 female connector with coupling nut, 8-pin, A coded, straight single ended 2 m [6.56'] PUR cable ³⁾	05.00.60E1.8211.002M
	M12 female connector with coupling nut, 12-pin, cw single ended 2 m [6.56'] PVC cable ³⁾	8.0000.6901.0002
Connectors	M12 female connector with coupling nut, 8-pin, A coded, straight (metal)	05.CMB 8181-0
	M12 female connector with coupling nut, 12-pin, cw	8.0000.5012.0000

Further Kübler accessories can be found at: kuebler.com/accessories
 Further Kübler cables and connectors can be found at: kuebler.com/connection-technology

1) For the cable connection type, cable material PUR.
 2) Not possible for flange type A and K.
 3) Other lengths available.

Incremental encoders

Standard sine wave output, SIL3/PLe, optical	Sendix 5814FS3 / 5834FS3 (shaft / hollow shaft)	SinCos
--	--	---------------

Technical data

Notes regarding "Functional Safety"	
These encoders are suitable for use in safety-related systems up to SIL3 acc. to EN 61800-5-2 and PLe to EN ISO 13849-1 in conjunction with controllers or evaluation units, which possess the necessary functionality.	
Additional functions can be found in the operating manual.	

Safety characteristics	
Classification	PLe / SIL3
System structure	2 channel (Cat. 4)
PFH_a value³⁾	1.09 x 10 ⁻⁹ h ⁻¹
Mission time / Proof test interval	20 years
Relevant standards	EN ISO 13849-1:2015; EN ISO 13849-2:2012; EN 61800-5-2:2007

Mechanical characteristics	
Maximum speed, shaft version	up to 70 °C [158 °F] 12000 min ⁻¹ , 10000 min ⁻¹ (continuous) up to T _{max} 8000 min ⁻¹ , 5000 min ⁻¹ (continuous)
Maximum speed, hollow shaft version	up to 70 °C [158 °F] 9000 min ⁻¹ , 6000 min ⁻¹ (continuous) up to T _{max} 6000 min ⁻¹ , 3000 min ⁻¹ (continuous)
Starting torque – at 20 °C [68 °F]	shaft version < 0.01 Nm hollow shaft version < 0.03 Nm
Mass moment of inertia	shaft version 4.0 x 10 ⁻⁶ kgm ² hollow shaft version 7.0 x 10 ⁻⁶ kgm ²
Insertion depth for shaft	hollow shaft version min. 34 mm [1.34"]
Load capacity of shaft	radial 80 N axial 40 N
Weight	approx. 0.45 kg [15.87 oz]
Protection acc. to EN 60529	IP65, IP67
Working temperature range	-40 °C ... +90 °C [-40 °F ... +194 °F] ¹⁾
Materials	shaft / hollow shaft stainless steel flange aluminum housing zinc die-cast cable PVC (PUR for Ex 2/22)
Shock resistance acc. to EN 60068-2-27	500 m/s ² , 11 ms
Vibration resistance acc. to EN 60068-2-6	200 m/s ² , 5 ... 2000 Hz

Electrical characteristics	
Supply voltage	5 V DC (±5 %) or 10 ... 30 V DC
Power consumption (no load)	5 V DC max. 70 mA 10 ... 30 V DC max. 45 mA
Reverse polarity protection of the supply voltage	yes
Short circuit proof outputs	yes ²⁾

EMC	
Relevant standards	EN 55011 class B:2009 / A1:2010 EN 61326-1:2013 EN 61326-3-1:2008

SinCos interface	
Max. frequency -3dB	400 kHz
Signal level	1 V _{pp} (±10 %)
Short circuit proof	yes ²⁾
Pulse rate	1024 / 2048 ppr

Approvals	
UL compliant in accordance with	File no. E224618
CE compliant in accordance with	
EMC Directive	2014/30/EU
RoHS Directive	2011/65/EU
ATEX Directive	2014/34/EU (for Ex 2/22 variants)
Machinery Directive	2006/42/EG

1) Cable version: -30 °C ... +90 °C [-22 °F ... +194 °F] fixed installation.
 2) Short circuit to 0 V or to output, one channel at a time, supply voltage correctly applied.
 3) The specified value is based on a diagnostic coverage of 99 %, that must be achieved with an encoder evaluation unit.
 The encoder evaluation unit must meet at least the requirements for SIL3.

Incremental encoders

Standard sine wave output, SIL3/PLe, optical	Sendix 5814FS3 / 5834FS3 (shaft / hollow shaft)	SinCos
---	--	---------------

Terminal assignment

Output circuit	Type of connection	Cable (isolate unused cores individually before initial start-up)							
1, 2	1, 2, A, B, E, F	Signal:	0 V	+V	A	\bar{A}	B	\bar{B}	\perp
		Core color:	WH	BN	GN	YE	GY	PK	shield

Output circuit	Type of connection	M23 connector, 12-pin							
1, 2	3, 4	Signal:	0 V	+V	A	\bar{A}	B	\bar{B}	\perp
		Pin:	10	12	5	6	8	1	PH ¹⁾

Output circuit	Type of connection	M12 connector, 8-pin							
1, 2	5, 6	Signal:	0 V	+V	A	\bar{A}	B	\bar{B}	\perp
		Pin:	1	2	3	4	5	6	PH ¹⁾

- +V: Supply voltage encoder +V DC
- 0 V: Supply voltage encoder ground GND (0 V)
- A, \bar{A} : Cosine signal
- B, \bar{B} : Sine signal
- PH \perp : Plug connector housing (shield)

Top view of mating side, male contact base

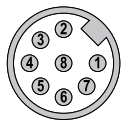

M12 connector, 8-pin

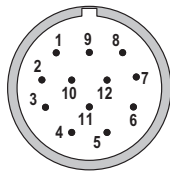

M23 connector, 12-pin

1) PH = shield is attached to connector housing.

Incremental encoders

Standard sine wave output, SIL3/PLe, optical	Sendix 5814FS3 / 5834FS3 (shaft / hollow shaft)	SinCos
--	--	---------------

Dimensions shaft version

Dimensions in mm [inch]

Clamping flange, \varnothing 58 [2.28]

Flange type 1 + 3 with shaft type 2

(drawing with cable)

- 1 3 x M3, 6 [0.24] deep
- 2 3 x M4, 8 [0.32] deep

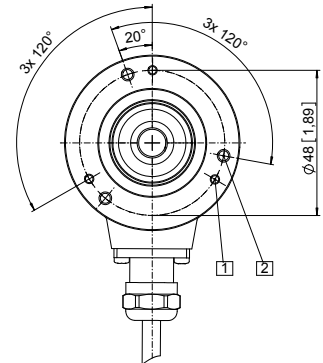
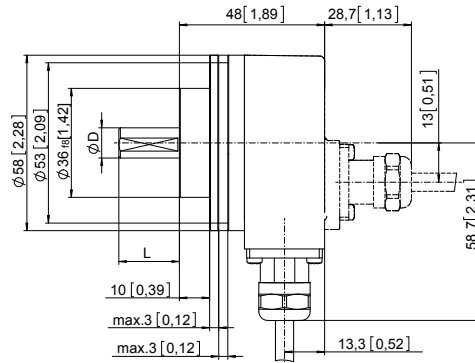

D	Fit	L
10 [0.39]	f7	20 [0.79]

Clamping flange, \varnothing 58 [2.28]

Flange type 1 + 3 with shaft type A

(drawing with M23 connector)

- 1 3 x M3, 6 [0.24] deep
- 2 3 x M4, 8 [0.32] deep
- 3 Feather key DIN 6885 - A - 3x3x6

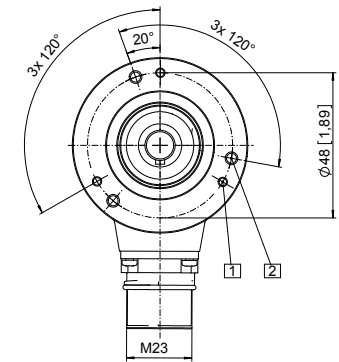
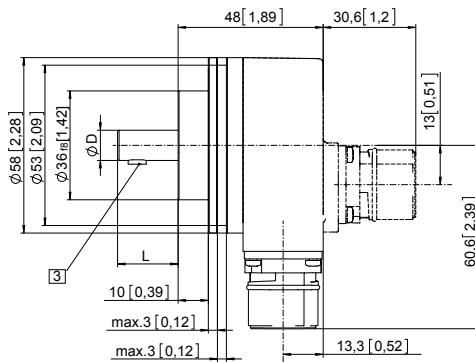

D	Fit	L
10 [0.39]	f7	20 [0.79]

(drawing with M12 connector)

- 1 3 x M3, 6 [0.24] deep
- 2 3 x M4, 8 [0.32] deep
- 3 Feather key DIN 6885 - A - 3x3x6

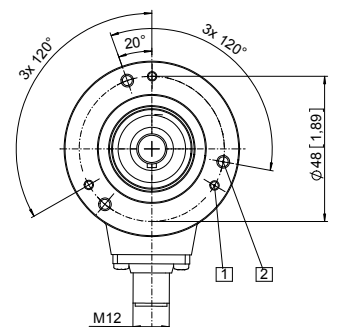
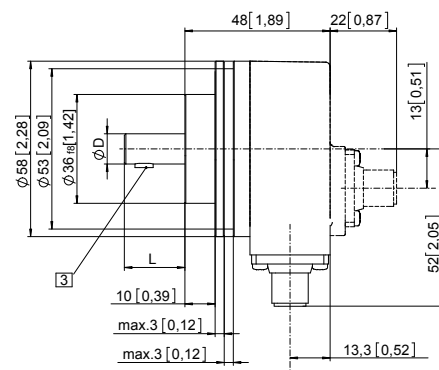

D	Fit	L
10 [0.39]	f7	20 [0.79]

Incremental encoders

Standard
sine wave output, SIL3/PLe, optical

Sendix 5814FS3 / 5834FS3 (shaft / hollow shaft)

SinCos

Dimensions hollow shaft version

Dimensions in mm [inch]

Flange with torque stop FS, rigid

Flange type A + K

Through hollow shaft

(drawing with cable)

- 1 SW 3, recommended torque for the clamping ring 2.5 Nm

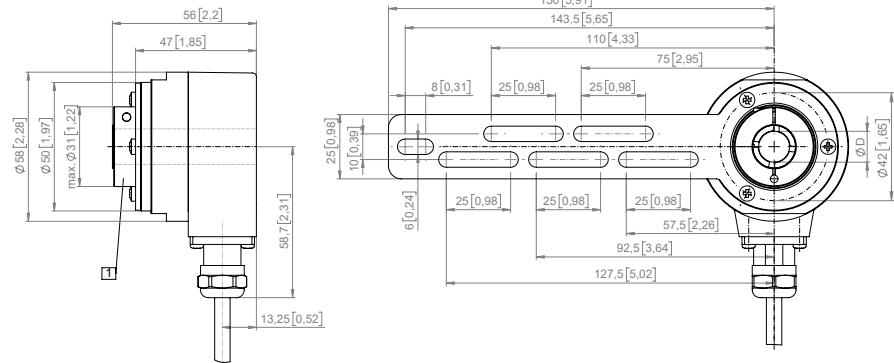

D	Fit
10 [0.39]	H7
12 [0.47]	H7
14 [0.55]	H7

(drawing with M12 connector)

- 1 SW 3, recommended torque for the clamping ring 2.5 Nm

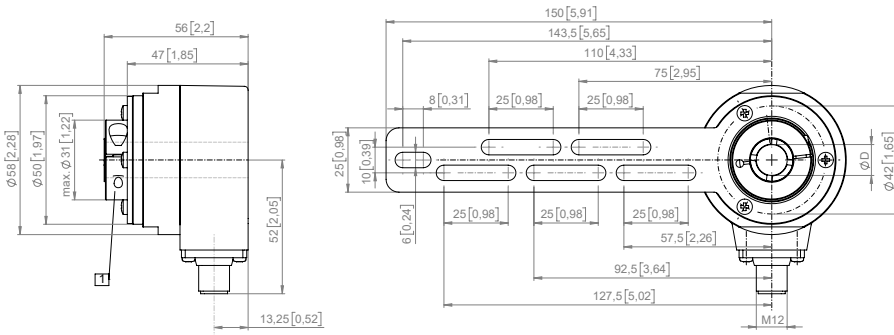

D	Fit
10 [0.39]	H7
12 [0.47]	H7
14 [0.55]	H7

Torque pin FS
with rectangular sleeve and M4 thread
(included in scope of delivery)

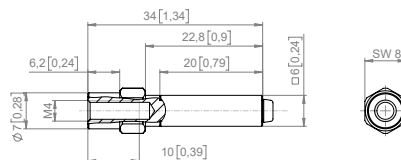

Incremental encoders

Standard sine wave output, SIL3/PLe, optical	Sendix 5814FS3 / 5834FS3 (shaft / hollow shaft)	SinCos
--	--	---------------

Dimensions hollow shaft version

Dimensions in mm [inch]

Flange with torque stop FS, flexible

Flange type 9 + J

Through hollow shaft

(drawing with M23 connector)

- 1 Recommended torque for the clamping ring 2.5 Nm

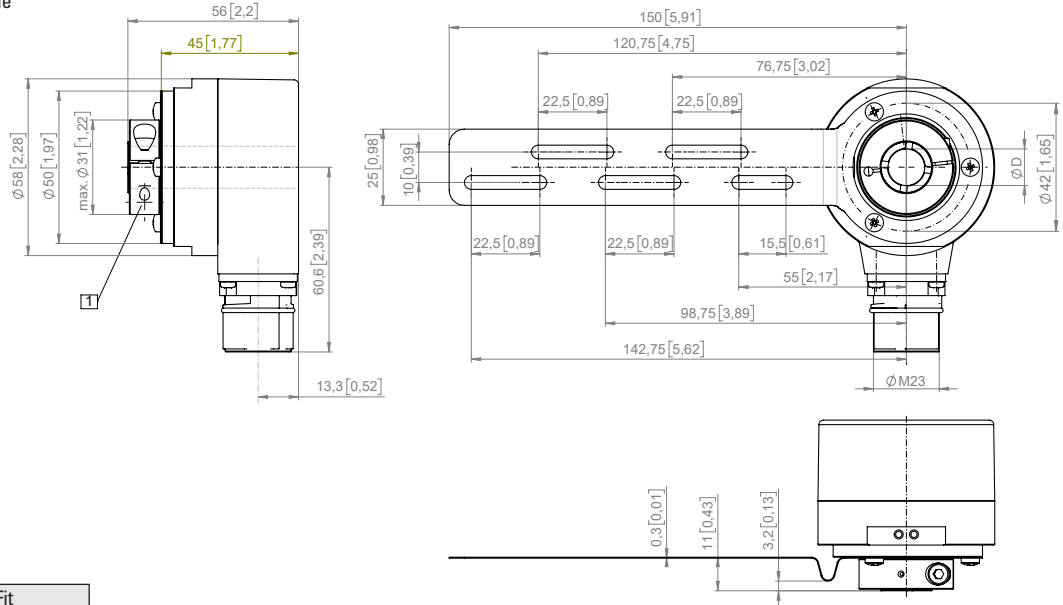

D	Fit
10 [0.39]	H7
12 [0.47]	H7
14 [0.55]	H7

Flange with stator coupling FS, ø 63 [2.48]

Flange type B + L

Through hollow shaft

(drawing with M23 connector)

- 1 SW 3, recommended torque for the clamping ring 2.5 Nm
- 2 For (4x) M3 screw

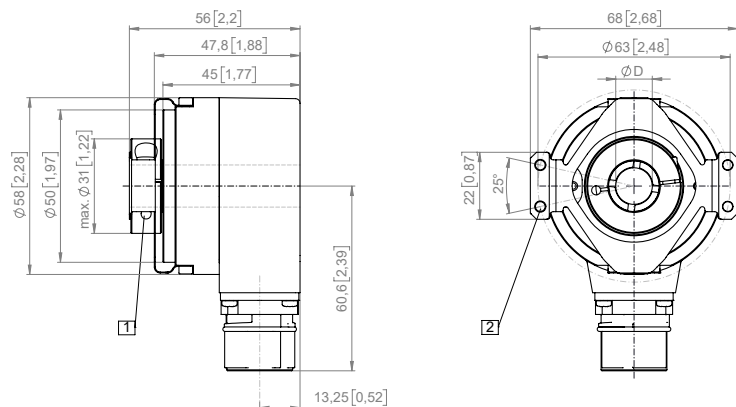

D	Fit
10 [0.39]	H7
12 [0.47]	H7
14 [0.55]	H7

Incremental encoders

Standard
sine wave output, SIL3/PLe, optical

Sendix 5814FS3 / 5834FS3 (shaft / hollow shaft)

SinCos

Dimensions hollow shaft version

Dimensions in mm [inch]

Flange with stator coupling FS, \varnothing 63 [2.48]

Flange type B + L

Tapered shaft

(drawing with tangential cable outlet)

- 1 For (4x) M3 screw
- 2 Status-LED
- 3 SET button
- 4 Recommended torque for central screw M5 (SW 4) $3.0^{+0.5}$ Nm (tapered shaft)

