

# Absolute encoders - singleturn

<b>Standard optical</b>	<b>Sendix 5858 / 5878 (shaft / hollow shaft)</b>	<b>EtherCAT</b>
-------------------------	--	-----------------



The singleturn encoders 5858 and 5878 with second-generation EtherCAT interface and optical sensor technology are ideal for use in all applications with an EtherCAT interface.

The data communication is based on CAN over EtherNet and ideally suited for use in real time applications.

These encoders are available with a solid shaft up to a maximum of 10 mm or a blind hollow shaft up to 15 mm.



**EtherCAT**  
Conformance tested

Safety-Lock™	High rotational speed	Temperature range -40...+80°C	High protection level IP	High shaft load capacity	Shock / vibration resistant	Magnetic field proof	Short-circuit proof	Reverse polarity protection	Optical sensor	Surface protection salt spray-tested optional

## Reliable

- EtherCAT conformance tested.
- Integration of the latest slave – EtherCAT stack from Beckhoff, version 5.01.
- Ideally suited for use in harsh outdoor environments, thanks to IP67 protection and rugged housing construction.

## Flexible

- Use of CoE (CAN over EtherNet).
- Genuine new position information as a result of minimal cycle time of 62.5 µs in the DC mode.
- Faster, easier error-free connection thanks to M12 connectors.
- Supports Hot-Connect.

**Order code** 8.5858 . X X B 2 . B2 12  
**Shaft version** Type a b c d e

If for each parameter of an encoder the underlined preferred option is selected, then the delivery time will be 10 working days for a maximum of 10 pieces. Qts. up to 50 pcs. of these types generally have a delivery time of 15 working days.



<p><b>a Flange</b></p> <p><u>1 = clamping flange, IP65 ø 58 mm [2.28"]</u> 3 = clamping flange, IP67 ø 58 mm [2.28"] <u>2 = synchro flange, IP65 ø 58 mm [2.28"]</u> 4 = synchro flange, IP67 ø 58 mm [2.28"] 5 = square flange, IP65 □ 63.5 mm [2.5"] 7 = square flange, IP67 □ 63.5 mm [2.5"]</p>	<p><b>b Shaft (ø x L), with flat</b></p> <p><u>1 = 6 x 10 mm [0.24 x 0.39"]</u><sup>1)</sup> <u>2 = 10 x 20 mm [0.39 x 0.79"]</u><sup>2)</sup> 3 = 1/4" x 7/8" 4 = 3/8" x 7/8"</p>	<p><b>c Interface / supply voltage</b></p> <p><u>B = EtherCAT / 10 ... 30 V DC</u></p>	<p><b>e Fieldbus profile</b></p> <p><u>B2 = EtherCAT with CoE (CAN over EtherNet)</u></p> <p>Optional on request - Ex 2/22 - surface protection salt spray tested</p>
<p><b>d Type of connection</b></p> <p><u>2 = 3 x M12 connector, 4-pin</u></p>			

**Order code** 8.5878 . X X B 2 . B2 12  
**Hollow shaft** Type a b c d e

If for each parameter of an encoder the underlined preferred option is selected, then the delivery time will be 10 working days for a maximum of 10 pieces. Qts. up to 50 pcs. of these types generally have a delivery time of 15 working days.



<p><b>a Flange</b></p> <p>1 = with spring element, long, IP65 2 = with spring element, long, IP67 3 = with stator coupling, IP65 ø 65 mm [2.56"] 4 = with stator coupling, IP67 ø 65 mm [2.56"] <u>5 = with stator coupling, IP65 ø 63 mm [2.48"]</u> 6 = with stator coupling, IP67 ø 63 mm [2.48"]</p>	<p><b>b Blind hollow shaft (insertion depth max. 30 mm [1.18"])</b></p> <p>3 = ø 10 mm [0.39"] <u>4 = ø 12 mm [0.47"]</u> 5 = ø 14 mm [0.55"] 6 = ø 15 mm [0.59"] 8 = ø 3/8" 9 = ø 1/2"</p>	<p><b>c Interface / supply voltage</b></p> <p><u>B = EtherCAT / 10 ... 30 V DC</u></p>	<p><b>e Fieldbus profile</b></p> <p><u>B2 = EtherCAT with CoE (CAN over EtherNet)</u></p> <p>Optional on request - Ex 2/22 - surface protection salt spray tested</p>
<p><b>d Type of connection</b></p> <p><u>2 = 3 x M12 connector, 4-pin</u></p>			

1) Preferred type only in conjunction with flange type 2.  
2) Preferred type only in conjunction with flange type 1.

# Absolute encoders - singleturn

<b>Standard optical</b>	<b>Sendix 5858 / 5878 (shaft / hollow shaft)</b>	<b>EtherCAT</b>
-------------------------	--	-----------------

Mounting accessory for shaft encoders		Order no.
<b>Coupling</b>	bellows coupling ø 19 mm [0.75"] for shaft 6 mm [0.24"]	<b>8.0000.1102.0606</b>
	bellows coupling ø 19 mm [0.75"] for shaft 10 mm [0.39"]	<b>8.0000.1102.1010</b>

Mounting accessory for hollow shaft encoders		Order no.
<b>Torque pin, ø 4 mm</b> for flange with spring element (flange type 1 + 2)	with fixing thread 	<b>8.0010.4700.0000</b>

Cables and connectors			Order no.
<b>Preassembled cables</b>	M12 male connector with external thread, 4-pin, D coded, straight single-ended 2 m [6.56'] PUR cable	Bus IN + Bus OUT	<b>05.00.6031.4411.002M</b>
	M12 female connector with coupling nut, 4-pin, A coded, straight single-ended 2 m [6.56'] PUR cable	supply voltage	<b>05.00.6061.6211.002M</b>
<b>Connectors</b>	M12 male connector with external thread, 4-pin, D coded, straight (metal)	Bus IN + Bus OUT	<b>05.WASCSY4S</b>
	M12 female connector with coupling nut, 4-pin, A coded, straight (plastic)	supply voltage	<b>05.B8141-0</b>

Further Kübler accessories can be found at: [kuebler.com/accessories](http://kuebler.com/accessories)  
 Further Kübler cables and connectors can be found at: [kuebler.com/connection-technology](http://kuebler.com/connection-technology)

## Technical data

Mechanical characteristics		
<b>Maximum speed</b>	IP65 up to 70 °C [158 °F]	9000 min <sup>-1</sup> , 7000 min <sup>-1</sup> (continuous)
	IP65 up to T <sub>max</sub>	7000 min <sup>-1</sup> , 4000 min <sup>-1</sup> (continuous)
	IP67 up to 70 °C [158 °F]	8000 min <sup>-1</sup> , 6000 min <sup>-1</sup> (continuous)
	IP67 up to T <sub>max</sub>	6000 min <sup>-1</sup> , 3000 min <sup>-1</sup> (continuous)
<b>Starting torque - at 20 °C [68 °F]</b>	IP65	< 0.01 Nm
	IP67	< 0.05 Nm
<b>Mass moment of inertia</b>	shaft version	3.0 x 10 <sup>-6</sup> kgm <sup>2</sup>
	hollow shaft version	6.9 x 10 <sup>-6</sup> kgm <sup>2</sup>
<b>Load capacity of shaft</b>	radial	80 N
	axial	40 N
<b>Weight</b>		approx. 0.50 kg [17.64 oz]
<b>Protection acc. to EN 60529</b>	housing side	IP67
	shaft side	IP65, opt. IP67
<b>Working temperature range</b>		-40 °C ... +80 °C [-40 °F ... +176 °F]
<b>Material</b>	shaft/hollow shaft	stainless steel
	flange	aluminum
	housing	zinc die-cast
<b>Shock resistance acc. to EN 60068-2-27</b>		2500 m/s <sup>2</sup> , 6 ms
<b>Vibration resistance acc. to EN 60068-2-6</b>		100 m/s <sup>2</sup> , 55 ... 2000 Hz

Electrical characteristics	
<b>Supply voltage</b>	10 ... 30 V DC
<b>Power consumption (no load)</b>	max. 110 mA
<b>Reverse polarity protection of the supply voltage</b>	yes

Interface characteristics EtherCAT	
<b>Resolution</b>	1 ... 65535 (16 bit), scalable default: 8192 (13 bit)
<b>Protocol</b>	EtherNet / EtherCAT

Approvals		
<b>UL compliant</b> in accordance with		File no. E224618
<b>CE compliant</b> in accordance with	EMC Directive	2014/30/EU
	RoHS Directive	2011/65/EU
	ATEX Directive	2014/34/EU (for Ex 2/22 variants)

# Absolute encoders - singleturn

Standard optical	Sendix 5858 / 5878 (shaft / hollow shaft)	EtherCAT
<b>Diagnostic LED (red)</b> LED is ON with the following fault conditions: Sensor error (internal code or LED error), low voltage, over-temperature		<b>2 x Link LEDs (yellow)</b> LED is ON with the following conditions (port IN and port OUT): Link detected
<b>Run LED (green)</b> LED is ON with the following conditions: Preop-, Safeop and Op-State (EtherCAT status machine)		<b>Modes</b> Freerun, Distributed Clock

## General information about CoE (CAN over EtherNet)

The EtherCAT encoders support the CANopen communication profile according to DS301. In addition device-specific profiles like the encoder profile DS406 are available.

Scaling, preset values, limit switch values and many other parameters can be programmed via the EtherCAT bus.

When switching the device on, all parameters are loaded from an EEPROM, where they were saved previously to protect them against power-failure.

The following output values may be combined as PDO (PDO mapping): **position, speed, temperature values** and **working area state** as well as other process values.

## CANopen encoder profile 3.2.10 CoE (CAN over EtherNet)

The following parameters are programmable:

- Position update time of 62.5  $\mu$ s.
- EtherCAT certificate of conformity.
- Speed with sign.
- Four units for speed calculation: steps/sec, steps/100 ms, steps/10 ms, rotation/min.
- Time stamp as system time at the point in time when the position is read out.
- Two working area state registers.
- Along with the scaled position, the raw data – position as process value – is also mappable.
- Dynamic mapping.
- Gating time: setting of the time interval, via which the speed value can be interpolated.
- Sensor temperature in degrees Celsius.
- Comprehensive plausibility test when downloading parameters to the encoder.
- Alarm and warning messages.
- User interface with visual display of bus and fault status – 4 LEDs.
- Extended error management for position sensing with integrated temperature control.
- Implementation of the latest CANopen profile 3.2.10 from the 18th February 2011.
- Hot-Connect – Support for rapid change of Bus-topology.

## Terminal assignment bus

Interface	Type of connection	Function	M12 connector, 4-pin					Diagram
			Signal:	Transmit data+	Receive data+	Transmit data -	Receive data -	
B	2 (3 x M12 connector)	Bus port IN	Signal:	Transmit data+	Receive data+	Transmit data -	Receive data -	
			Abbreviation:	TxD+	RxD+	TxD-	RxD-	
			Pin:	1	2	3	4	
		Power supply	Signal:	Voltage +	–	Voltage –	–	
			Abbreviation:	+ V	–	0 V	–	
			Pin:	1	2	3	4	
		Bus port OUT	Signal:	Transmit data+	Receive data+	Transmit data -	Receive data -	
			Abbreviation:	TxD+	RxD+	TxD-	RxD-	
			Pin:	1	2	3	4	

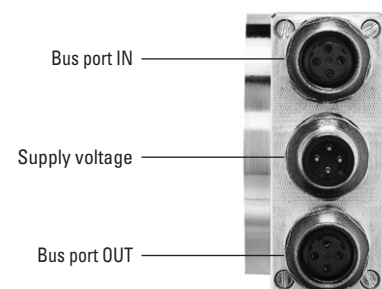

# Absolute encoders - singleturn

**Standard optical**

**Sendix 5858 / 5878 (shaft / hollow shaft)**

**EtherCAT**

## Dimensions shaft version, with removable bus terminal cover

Dimensions in mm [inch]

### Clamping flange, $\varnothing$ 58 [2.28]

Flange type 1 and 3

- 1 3 x M3, 6 [0.24] deep
- 2 3 x M4, 8 [0.32] deep

D	Fit	L
6 [0.24]	h7	10 [0.39]
10 [0.39]	f7	20 [0.79]
1/4"	h8	7/8"
3/8"	h8	7/8"

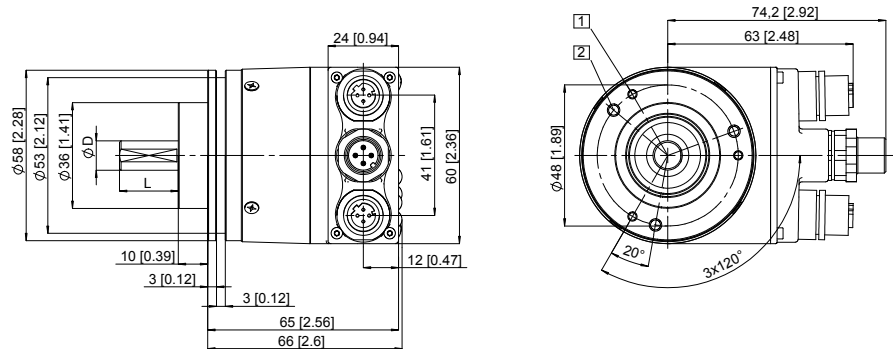

### Synchro flange, $\varnothing$ 58 [2.28]

Flange type 2 and 4

- 1 3 x M4, 6 [0.24] deep

D	Fit	L
6 [0.24]	h7	10 [0.39]
10 [0.39]	f7	20 [0.79]
1/4"	h8	7/8"
3/8"	h8	7/8"

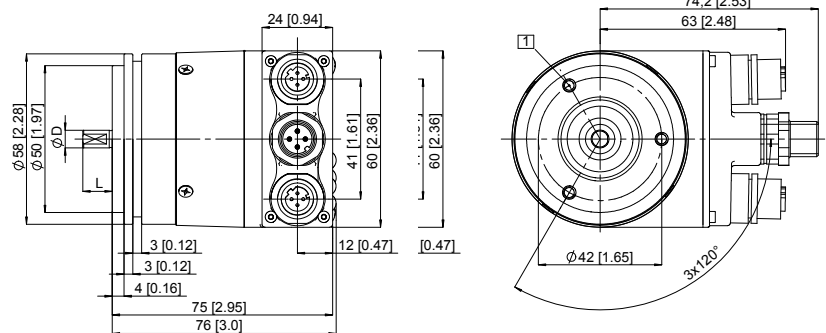

### Square flange, $\square$ 63.5 [2.5]

Flange type 5 and 7

D	Fit	L
6 [0.24]	h7	10 [0.39]
10 [0.39]	f7	20 [0.79]
1/4"	h8	7/8"
3/8"	h8	7/8"

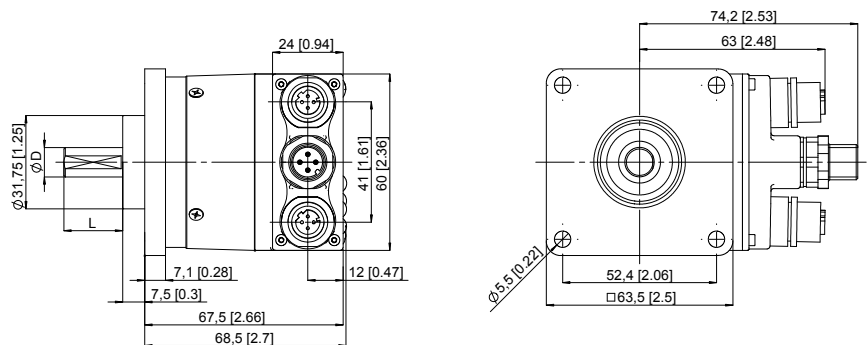

# Absolute encoders - singleturn

<b>Standard optical</b>	<b>Sendix 5858 / 5878 (shaft / hollow shaft)</b>	<b>EtherCAT</b>
-------------------------	--	-----------------

## Dimensions hollow shaft version (blind hollow shaft), with removable bus terminal cover

Dimensions in mm [inch]

### Flange with spring element, long Flange type 1 and 2

- 1 Slot spring element, recommendation: torque pin DIN 7,  $\varnothing$  4 [0.16]
- 2 3 x M3, 5.5 [0.22] deep
- 3 Recommended torque for the clamping ring 0.6 Nm

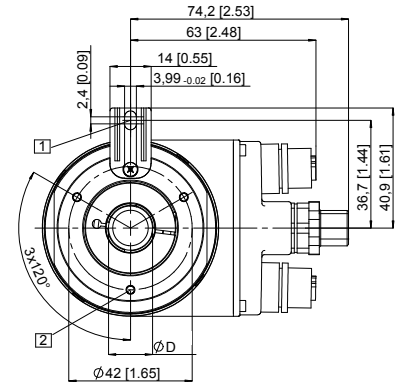
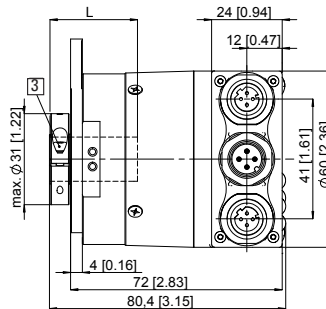

D	Fit	L
10 [0.39]	H7	30 [1.18]
12 [0.47]	H7	30 [1.18]
14 [0.55]	H7	30 [1.18]
15 [0.59]	H7	30 [1.18]
3/8"	H7	30 [1.18]
1/2"	H7	30 [1.18]

L = insertion depth max. blind hollow shaft

### Flange with stator coupling, $\varnothing$ 63 [2.48] Flange type 5 and 6

- 1 Fixing screws DIN 912 M3 x 8 (washer included in delivery)
- 2 Recommended torque for the clamping ring 0.6 Nm

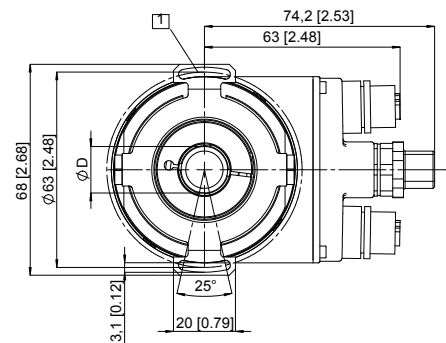
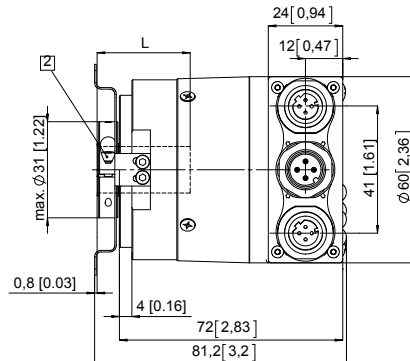

D	Fit	L
10 [0.39]	H7	30 [1.18]
12 [0.47]	H7	30 [1.18]
14 [0.55]	H7	30 [1.18]
15 [0.59]	H7	30 [1.18]
3/8"	H7	30 [1.18]
1/2"	H7	30 [1.18]

L = insertion depth max. blind hollow shaft

### Flange with stator coupling, $\varnothing$ 65 [2.56] Flange type 3 and 4

- 1 Recommended torque for the clamping ring 0.6 Nm

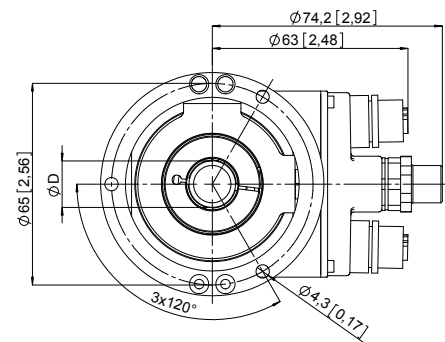
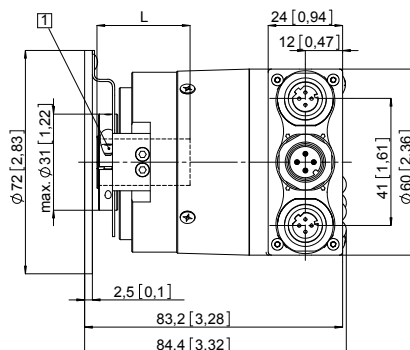

D	Fit	L
10 [0.39]	H7	30 [1.18]
12 [0.47]	H7	30 [1.18]
14 [0.55]	H7	30 [1.18]
15 [0.59]	H7	30 [1.18]
3/8"	H7	30 [1.18]
1/2"	H7	30 [1.18]

L = insertion depth max. blind hollow shaft