

Absolute encoders - singleturn

Standard optical	Sendix 5858 / 5878 (shaft / hollow shaft)	PROFINET IO
-------------------------	--	--------------------



The singleturn encoders 5858 and 5878 with PROFINET interface and optical sensor technology are ideal for use in all applications with a PROFINET interface.

The encoder supports the IRT mode and is therefore ideal for real-time applications.

Safety-Lock™	High rotational speed	Temperature range -40...+85°C	High protection level IP	High shaft load capacity	Shock / vibration resistant	Magnetic field proof	Short-circuit proof	Reverse polarity protection	Optical sensor	Surface protection salt spray-tested optional

Reliable

- Ideally suited for all PROFINET applications thanks to the use of encoder profile 4.1.
- Perfect for use in harsh outdoor environments, as a result of IP67 protection and rugged housing construction.

Flexible

- Easy setting of a preset value using a control bit (telegram 860).
- IRT-Mode.
- Cycle time ≥ 1 ms.
- Firmware updater allows for easy expansion of characteristics without having to disassemble the encoder.

Order code

Shaft version

8.5858 . X X C 2 . C2 12

Type

a b c d e

If for each parameter of an encoder the **underlined preferred option** is selected, then the delivery time will be 10 working days for a maximum of 10 pieces. Qts. up to 50 pcs. of these types generally have a delivery time of 15 working days.



a Flange

- 1 = clamping flange, IP65 \varnothing 58 mm [2.28"]
- 3 = clamping flange, IP67 \varnothing 58 mm [2.28"]
- 2 = synchro flange, IP65 \varnothing 58 mm [2.28"]
- 4 = synchro flange, IP67 \varnothing 58 mm [2.28"]
- 5 = square flange, IP65 \square 63.5 mm [2.5"]
- 7 = square flange, IP67 \square 63.5 mm [2.5"]

b Shaft ($\varnothing \times L$), with flat

- 1 = 6 x 10 mm [0.24 x 0.39"]¹⁾
- 2 = 10 x 20 mm [0.39 x 0.79"]²⁾
- 3 = 1/4" x 7/8"
- 4 = 3/8" x 7/8"

c Interface / supply voltage

- C = PROFINET IO / 10 ... 30 V DC

e Field bus profile

- C2 = PROFINET IO

d Type of connection

- removable bus terminal cover
- 2 = 3 x M12 connector, 4-pin

Optional on request

- Ex 2/22
- surface protection salt spray tested

Order code

Hollow shaft

8.5878 . X X C 2 . C2 12

Type

a b c d e

If for each parameter of an encoder the **underlined preferred option** is selected, then the delivery time will be 10 working days for a maximum of 10 pieces. Qts. up to 50 pcs. of these types generally have a delivery time of 15 working days.



a Flange

- 1 = with spring element, long, IP65
- 2 = with spring element, long, IP67
- 3 = with stator coupling, IP65 \varnothing 65 mm [2.56"]
- 4 = with stator coupling, IP67 \varnothing 65 mm [2.56"]
- 5 = with stator coupling, IP65 \varnothing 63 mm [2.48"]
- 6 = with stator coupling, IP67 \varnothing 63 mm [2.48"]

b Blind hollow shaft

- (insertion depth max. 30 mm [1.18"])
- 3 = \varnothing 10 mm [0.39"]
- 4 = \varnothing 12 mm [0.47"]
- 5 = \varnothing 14 mm [0.55"]
- 6 = \varnothing 15 mm [0.59"]
- 8 = \varnothing 3/8"
- 9 = \varnothing 1/2"

c Interface / supply voltage

- C = PROFINET IO / 10 ... 30 V DC

e Field bus profile

- C2 = PROFINET IO

d Type of connection

- removable bus terminal cover
- 2 = 3 x M12 connector, 4-pin

Optional on request

- Ex 2/22
- surface protection salt spray tested

1) Preferred type only in conjunction with flange type 2.
2) Preferred type only in conjunction with flange type 1.

Absolute encoders - singleturn

Standard optical	Sendix 5858 / 5878 (shaft / hollow shaft)	PROFINET IO
-------------------------	--	--------------------

Mounting accessory for shaft encoders		Order no.
Coupling	bellows coupling ø 19 mm [0.75"] for shaft 6 mm [0.24"]	8.0000.1102.0606
	bellows coupling ø 19 mm [0.75"] for shaft 10 mm [0.39"]	8.0000.1102.1010

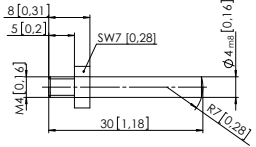
Mounting accessory for hollow shaft encoders		Order no.
Torque pin, ø 4 mm for flange with spring element (flange type 1 + 2)	with fixing thread 	8.0010.4700.0000

Cables and connectors		Order no.
Preassembled cables	M12 male connector with external thread, 4-pin, D coded, straight single-ended 2 m [6.56'] PUR cable	Bus IN + Bus OUT 05.00.6031.4411.002M
	M12 female connector with coupling nut, 4-pin, A coded, straight single-ended 2 m [6.56'] PUR cable	supply voltage 05.00.6061.6211.002M
Connectors	M12 male connector with external thread, 4-pin, D coded, straight (metal)	Bus IN + Bus OUT 05.WASCSY4S
	M12 female connector with coupling nut, 4-pin, A coded, straight (plastic)	supply voltage 05.B8141-0

Further Kübler accessories can be found at: kuebler.com/accessories
Further Kübler cables and connectors can be found at: kuebler.com/connection-technology

Technical data

Mechanical characteristics		
Maximum speed	IP65 up to 70 °C [158 °F]	9000 min ⁻¹ , 7000 min ⁻¹ (continuous)
	IP65 up to T _{max}	7000 min ⁻¹ , 4000 min ⁻¹ (continuous)
	IP67 up to 70 °C [158 °F]	8000 min ⁻¹ , 6000 min ⁻¹ (continuous)
	IP67 up to T _{max}	6000 min ⁻¹ , 3000 min ⁻¹ (continuous)
Starting torque - at 20 °C [68 °F]	IP65	< 0.01 Nm
	IP67	< 0.05 Nm
Mass moment of inertia	shaft version	3.0 x 10 ⁻⁶ kgm ²
	hollow shaft version	6.0 x 10 ⁻⁶ kgm ²
Load capacity of shaft	radial	80 N
	axial	40 N
Weight		approx. 0.50 kg [17.64 oz]
Protection acc. to EN 60529	housing side	IP67
	shaft side	IP65, opt. IP67
Working temperature range		-40 °C ... +85 °C [-40 °F ... +185 °F]
Material	shaft/hollow shaft	stainless steel
	flange	aluminum
	housing	zinc die-cast
Shock resistance acc. to EN 60068-2-27		2500 m/s ² , 6 ms
Vibration resistance acc. to EN 60068-2-6		100 m/s ² , 55 ... 2000 Hz

Electrical characteristics	
Supply voltage	10 ... 30 V DC
Power consumption (no load)	max. 200 mA
Reverse polarity protection of the supply voltage	yes

Interface characteristics PROFINET IO	
Resolution	1 ... 65535 (16 bit), scalable default: 8192 (13 bit)
Protocol	PROFINET IO

Link 1 and 2, LED (green / yellow)		
Two colored	green	active link
	yellow	data transfer

Error LED (red) / PWR LED (green)	
Functionality see manual	

Approvals		
UL compliant in accordance with		File no. E224618
CE compliant in accordance with	EMC Directive	2014/30/EU
	RoHS Directive	2011/65/EU
	ATEX Directive	2014/34/EU (for Ex 2/22 variants)
UKCA compliant in accordance with	EMC Regulations	S.I. 2016/1091
	RoHS Regulations	S.I. 2012/3032
	UKEX Regulations	S.I. 2016/1107 (for Ex 2/22 variants)

Absolute encoders - singleturn

Standard optical	Sendix 5858 / 5878 (shaft / hollow shaft)	PROFINET IO
-------------------------	--	--------------------

General information about PROFINET IO

The PROFINET encoder implements the encoder profile 4.1. (according to the specification Encoder Version 4.1 Dec 2008“)

It permits scaling and preset values, as well as many other additional parameters to be programmed via the PROFINET bus.

When switching on, all parameters are loaded from an EEPROM, where they were saved previously to protect them against power-failure, or taken over by the controller in the start-up phase.

Position, speed and many other states of the encoder can be transmitted.



PROFINET IO

The complete encoder profile according to profile encoder version 4.1 as well as the identification & maintenance functionality version 1.16 has been implemented. IM blocks 0, 1, 2, 3 and 4 are supported.

The **M**edia **R**edundancy **P**rotocol is implemented here.

Basically, the advantage of MRP is that the functionality of the components, which are wired in a ring structure, is maintained in case of a failure or of a breakage of the wires in any location.

Terminal assignment bus

Interface	Type of connection	Function	M12 connector, 4-pin					
			Signal:	Transmit data+	Receive data+	Transmit data -	Receive data -	
C	2 (3 x M12 connector)	Bus port 1	Signal:	Transmit data+	Receive data+	Transmit data -	Receive data -	 D coded
			Abbreviation:	TxD+	RxD+	TxD-	RxD-	
			Pin:	1	2	3	4	
		Power supply	Signal:	Voltage +	-	Voltage -	-	 D coded
			Abbreviation:	+ V	-	0 V	-	
			Pin:	1	2	3	4	
		Bus port 2	Signal:	Transmit data+	Receive data+	Transmit data -	Receive data -	 D coded
			Abbreviation:	TxD+	RxD+	TxD-	RxD-	
			Pin:	1	2	3	4	

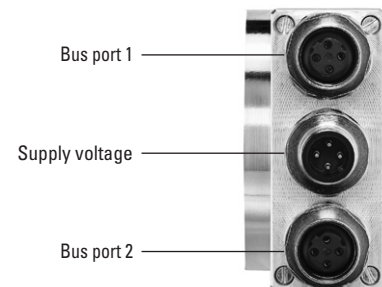

Standard optical

Sendix 5858 / 5878 (shaft / hollow shaft)

PROFINET IO

Technology in detail

Clock synchronicity – Isochronous Real Time (IRT) in position sensor technology

In general, for time-critical applications, focus is set on very short sensor cycle times. However, in order to achieve high control performance, simply accelerating data acquisition and processing by shortest cycle times is not sufficient. All sensors and actuators are to operate according to the same clock.

This is achieved thanks to a clock used for the whole network, defined by the controller. This transmit clock cycle (IRT clock) is however not necessarily the clock cycle used for process data exchange. Another cycle (application cycle) is used for this purpose, which can also be defined by the customer controller. The illustration below represents the connection between the different clock cycles.

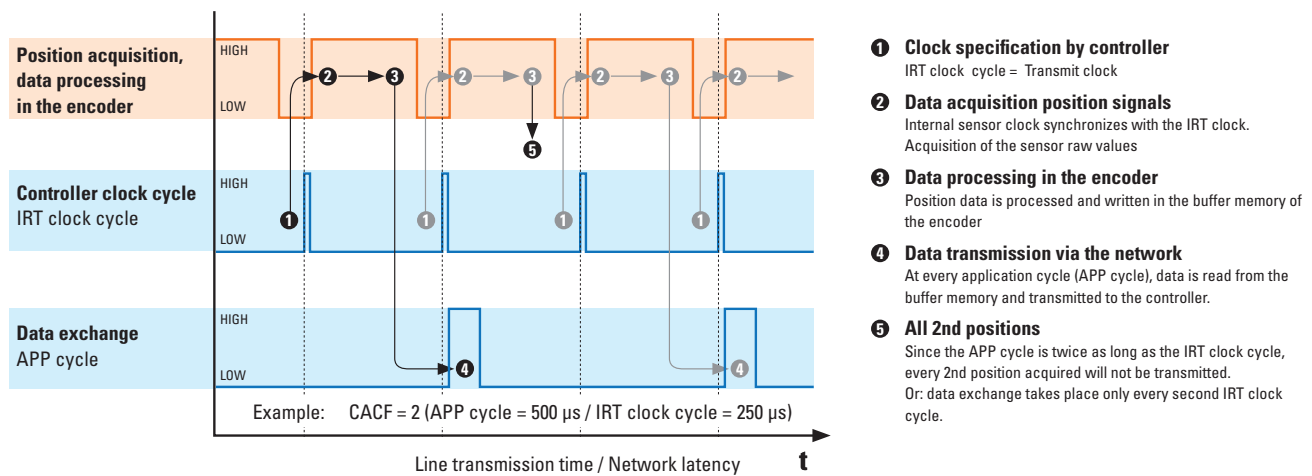

When receiving the IRT clock signal, the sensor starts reading its current measured point. This raw value is processed internally (e.g. scaling, speed calculation, etc.) and stored in a buffer memory.

The buffer memory is read at every application cycle. If it contains a value, this value is transmitted to the controller via the network.

If the application cycle is a multiple of the IRT clock cycle, it may happen that the buffered process data is not sent directly, but is overwritten, because, even though this data is acquired with every IRT clock cycle, it is sent only with every application cycle.

The ratio between application cycle and IRT clock cycle represents the CACF (Controller Application Cycle Factor).

In this example, the $CACF = 2$. This indicates that only every 2nd acquired position will be transmitted to the controller.

The described methodology guarantees a determinism: since the controller defines a clock cycle for the whole network, this allows ensuring that all measured values transmitted by the sensors to the controller are never older than the selected IRT cycle! Therefore, all downstream actuators can always be regulated on the basis of the latest available measured values.

Absolute encoders - singleturn

Standard optical	Sendix 5858 / 5878 (shaft / hollow shaft)	PROFINET IO
-------------------------	--	--------------------

Dimensions shaft version, with removable bus terminal cover

Dimensions in mm [inch]

Clamping flange, \varnothing 58 [2.28]

Flange type 1 and 3

- 1 3 x M3, 6 [0.24] deep
- 2 3 x M4, 8 [0.32] deep

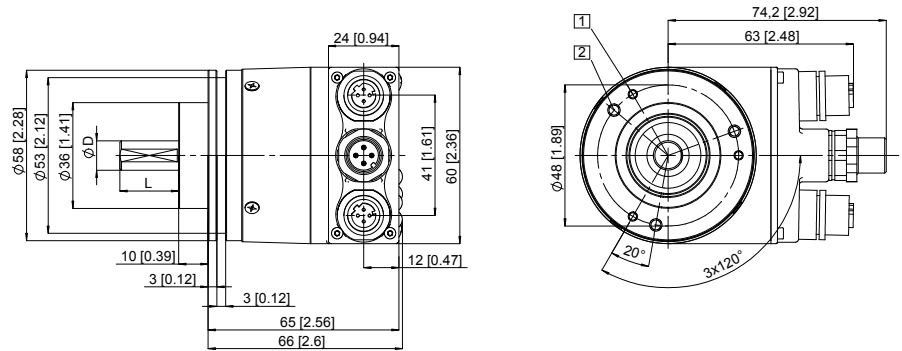

D	Fit	L
6 [0.24]	h7	10 [0.39]
10 [0.39]	f7	20 [0.79]
1/4"	h8	7/8"
3/8"	h8	7/8"

Synchro flange, \varnothing 58 [2.28]

Flange type 2 and 4

- 1 3 x M4, 6 [0.24] deep

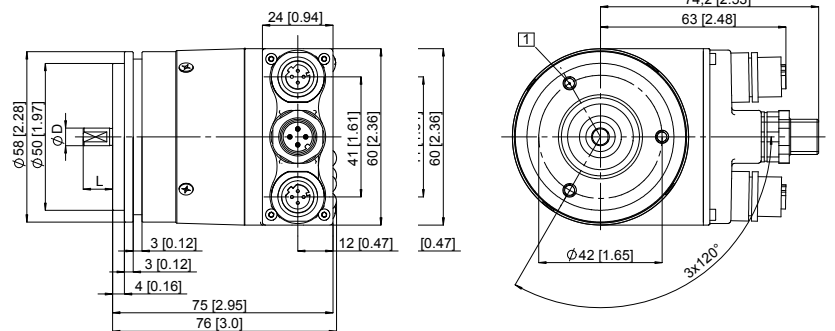

D	Fit	L
6 [0.24]	h7	10 [0.39]
10 [0.39]	f7	20 [0.79]
1/4"	h8	7/8"
3/8"	h8	7/8"

Square flange, \square 63.5 [2.5]

Flange type 5 and 7

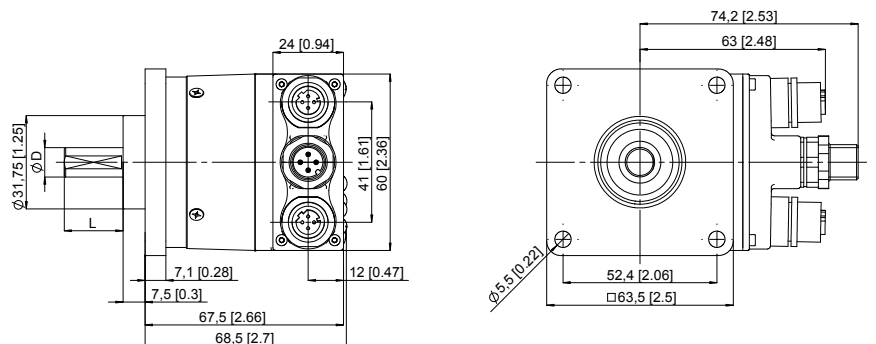

D	Fit	L
6 [0.24]	h7	10 [0.39]
10 [0.39]	f7	20 [0.79]
1/4"	h8	7/8"
3/8"	h8	7/8"

Absolute encoders - singleturn

Standard optical

Sendix 5858 / 5878 (shaft / hollow shaft)

PROFINET IO

Dimensions hollow shaft version (blind hollow shaft), with removable bus terminal cover

Dimensions in mm [inch]

Flange with spring element, long Flange type 1 and 2

- 1 Slot spring element, recommendation: cylindrical pin DIN 7, $\varnothing 4$ [0.16]
- 2 3 x M3, 5.5 [0.22] deep
- 3 Recommended torque for the clamping ring 0.6 Nm

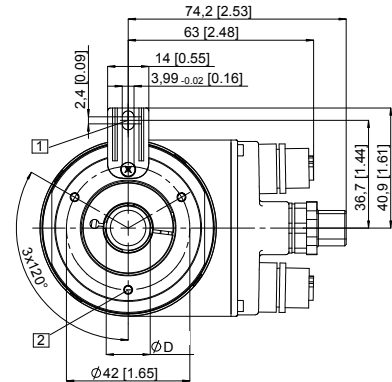
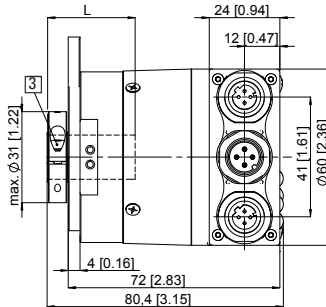

D	Fit	L
10 [0.39]	H7	30 [1.18]
12 [0.47]	H7	30 [1.18]
14 [0.55]	H7	30 [1.18]
15 [0.59]	H7	30 [1.18]
3/8"	H7	30 [1.18]
1/2"	H7	30 [1.18]

L = insertion depth max. blind hollow shaft

Flange with stator coupling, $\varnothing 63$ [2.48] Flange type 5 and 6

- 1 Fixing screws DIN 912 M3 x 8 (washer included in delivery)
- 2 Recommended torque for the clamping ring 0.6 Nm

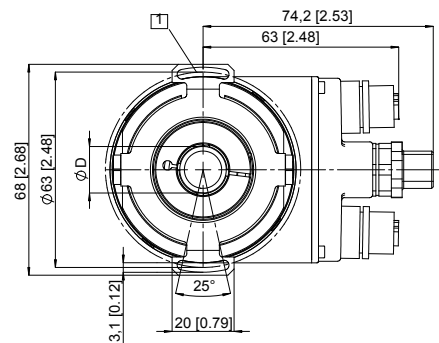
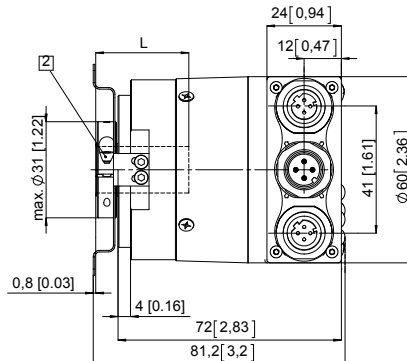

D	Fit	L
10 [0.39]	H7	30 [1.18]
12 [0.47]	H7	30 [1.18]
14 [0.55]	H7	30 [1.18]
15 [0.59]	H7	30 [1.18]
3/8"	H7	30 [1.18]
1/2"	H7	30 [1.18]

L = insertion depth max. blind hollow shaft

Flange with stator coupling, $\varnothing 65$ [2.56] Flange type 3 and 4

- 1 Recommended torque for the clamping ring 0.6 Nm

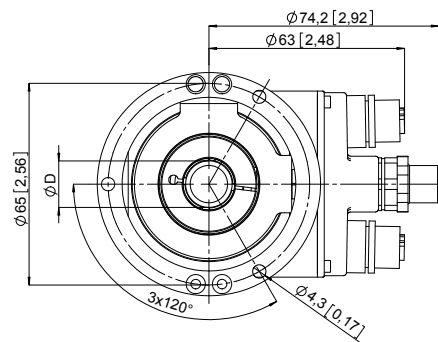
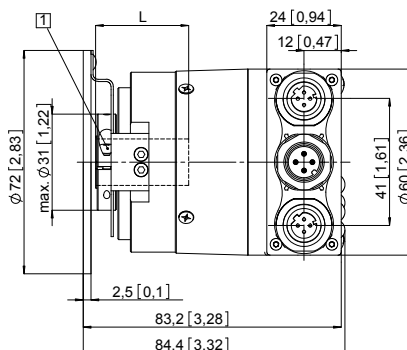

D	Fit	L
10 [0.39]	H7	30 [1.18]
12 [0.47]	H7	30 [1.18]
14 [0.55]	H7	30 [1.18]
15 [0.59]	H7	30 [1.18]
3/8"	H7	30 [1.18]
1/2"	H7	30 [1.18]

L = insertion depth max. blind hollow shaft