

Absolute encoders - singleturn

Standard Motor-Line, optical	Sendix 5873 (tapered shaft)	SSI / BiSS + incremental
-------------------------------------	------------------------------------	---------------------------------



The optical Sendix 5873 singleturn encoders with SSI or BiSS interface and optional 2048 ppr SinCos incremental track reach a resolution of up to 21 bits.

Advantages: Plug-and-Play for commissioning, including electronic data sheet and possibility to set the absolute measuring system to a predefined position value.

Specially designed for mounting on direct drives in the elevator technology.



Reliable and insensitive

- Sturdy bearing construction in Safety-Lock™ design for resistance against vibration and installation errors.
- Encoder specially designed for mounting on direct drives in the elevator technology.

Versatile

- High-precision with a data refresh rate of the position value $\leq 1 \mu\text{s}$.
- High-resolution feedback in real-time via 21 bit fully digital or incremental outputs SinCos and RS422.
- BiSS-C BP3 encoder profile.
- Short control cycles, clock rate with SSI up to 2 MHz / with BiSS up to 10 MHz.

Order code Tapered shaft

8.5873	.	X	K	X	X	.	X	X	2	X
Type		a	b	c	d		e	f	g	h

a Flange

- G = with stator coupling, $\varnothing 72 \text{ mm}$ [2.83"]
- H = with expanding coupling, $\varnothing 65 \text{ mm}$ [2.56"]

b Tapered shaft

- K = $\varnothing 10 \text{ mm}$ [0.39"]

c Interface / supply voltage

- 1 = SSI, BiSS / 5 V DC
- 2 = SSI, BiSS / 10 ... 30 V DC
- 3 = SSI, BiSS + 2048 ppr. SinCos / 5 V DC
- 4 = SSI, BiSS + 2048 ppr. SinCos / 10 ... 30 V DC
- 5 = SSI, BiSS / 5 V DC, with sensor output
- 6 = SSI, BiSS + 2048 ppr. SinCos / 5 V DC, with sensor output
- 9 = SSI, BiSS + 2048 ppr. RS422 (TTL-comp.) / 5 V DC, with sensor output
- E = SSI, BiSS + 2048 ppr. SinCos / 4.5 ... 5.5 V DC, with sensor output¹⁾

d Type of connection

- E = tangential cable, 1 m PVC
- F = tangential cable, length PVC see below *)
- G = tangential cable, with Sub-D connector (male contact, 15-pin, double-row), length PVC s. below *)²⁾
- H = tangential cable, with Phoenix Contact connector (MC1.5/16-STF-3.81), length PVC s. below *)²⁾
- L = with PCB connector³⁾
(without cable, including sealing cap for tangential cable outlet)

*) Available lengths (connection types F, G, H):

2, 3, 5, 8, 10, 15 m [5.56, 9.84, 16.40, 26.25, 32.80, 49.21"]

order code expansion .XXXX = length in dm

ex.: 8.5873.GK2E.G323.0030 (for cable length 3 m)

e Code

- B = SSI, binary
- C = BiSS, binary
- G = SSI, gray

f Resolution⁴⁾

- A = 10 bit
- 1 = 11 bit
- 2 = 12 bit
- 3 = 13 bit
- 4 = 14 bit
- 7 = 17 bit
- C = 21 bit⁵⁾

g Options (service)

- 1 = no option
- 2 = status LED
- 3 = SET button and status LED

1) Without reverse polarity protection.

2) Can be combined as a standard only with interface E (other variants on request).

3) IP40, only available without SET button and status LED, not available with interface 9, see the Accessories for the suitable connection cable.

4) Resolution, preset value and counting direction factory-programmable.

5) Only in conjunction with interface 1 or 2.

Absolute encoders - singleturn

Standard Motor-Line, optical	Sendix 5873 (tapered shaft)	SSI / BiSS + incremental
-------------------------------------	------------------------------------	---------------------------------

Cables and connectors		Order no.
Preassembled cables (suitable for type of connection L)	PCB connector (female contacts), 12-pin single-ended 2 m [6.56'] PVC cable	8.0000.6D91.0002
	PCB connector (female contacts), 12-pin single-ended 8 m [26.25'] PVC cable	8.0000.6D91.0008

Further Kübler cables and connectors can be found at: kuebler.com/connection-technology

Technical data

Mechanical characteristics		
Maximum speed	up to 70 °C [158 °F]	12000 min ⁻¹ , 10000 min ⁻¹ (continuous)
	up to T _{max}	8000 min ⁻¹ , 5000 min ⁻¹ (continuous)
Starting torque at 20 °C [68 °F]		< 0.01 Nm
Mass moment of inertia		3.0 x 10 ⁻⁶ kgm ²
Load capacity of shaft	radial	80 N
	axial	40 N
Weight		approx. 0.35 kg [12.35 oz]
Protection acc. to EN 60529		IP65
Working temperature range		-40 °C ... +90 °C [-40 °F ... +194 °F] (+105 °C [+212 °F] with interface E) ¹⁾
Materials	tapered shaft	stainless steel
	flange	aluminum
	housing	zinc die-cast
	cable	PVC
Shock resistance acc. EN 60068-2-27		2500 m/s ² , 6 ms
Vibration resistance acc. EN 60068-2-6		100 m/s ² , 55 ... 2000 Hz

Electrical characteristics		
Supply voltage		5 V DC (+5 %)
		4.5 ... 5.5 V DC
		or 10 ... 30 V DC
Current consumption (no load)	5 V DC	max. 70 mA
	10 ... 30 V DC	max. 45 mA
Reverse polarity protection of the supply voltage		yes (not for interface E)
Short circuit proof outputs		yes ²⁾

SSI interface		
Output driver		RS485 transceiver type
Permissible load / channel		max. +/- 20 mA
Signal level	HIGH	typ. 3.8 V
	LOW at I _{Load} = 20 mA	typ. 1.3 V
Resolution		10 ... 14 bit and 17 bit
Code		binary or gray
SSI clock rate		50 kHz ... 2 MHz
Data refresh rate	ST resolution ≤ 14 bit	≤ 1 μs
	ST resolution ≥ 15 bit	4 μs
Monoflop time		≤ 15 μs

Note: If the clock starts cycling within the monoflop time, a second data transfer starts with the same data. If the clock starts cycling after the monoflop time, the data transfer starts with the new values. The update rate is dependent on the clock speed, data length and monoflop-time.

BiSS interface		
Output driver		RS485 transceiver type
Permissible load / channel		max. +/- 20 mA
Signal level	HIGH	typ. 3.8 V
	LOW at I _{Load} = 20 mA	typ. 1.3 V
Resolution		10 ... 14 bit; 17, 19 and 21 bit
Code		binary
Clock rate		50 kHz ... 10 MHz
Max. update rate		< 15 μs, depends on the clock rate and the data length
Data refresh rate	ST resolution ≤ 14 bit	≤ 1 μs
	ST resolution 17 bit	2.4 μs
	ST resolution 21 bit	4 μs
Protocol		BiSS-C BP3 encoder profile
Note:	<ul style="list-style-type: none"> - Bidirectional, factory programmable parameters are: resolution, code, direction, alarms and warnings - CRC data verification - EDS (electronic data sheet) 	

Status output and LED		
Output driver		open collector, internal pull up resistor 22 kOhm
Permissible load		max. 20 mA
Signal level	HIGH	+V
	LOW	< 1 V
Active		LOW
<p>The optional LED (red) and the status output serve to display various alarm or error messages. In normal operation the LED is OFF and the status output is HIGH (Open Collector with int. pull-up 22 kOhm).</p> <p>An active status output (LOW) displays:</p> <ul style="list-style-type: none"> - Sensor error, singleturn or multeturn (soiling, glass breakage etc.) - LED fault (failure or ageing) - over- or under-temperature <p>In the SSI mode, the fault indication can only be reset by switching off the supply voltage to the device.</p>		

1) Temperature measured on the flange – max. 80 °C allowable on the cable (fixed installation).
2) Short circuit to 0 V or to output, one channel at a time, supply voltage correctly applied.

Absolute encoders - singleturn

Standard Motor-Line, optical	Sendix 5873 (tapered shaft)		SSI / BiSS + incremental
Incremental outputs (A/B)			
	SinCos	RS422 TTL compatible	
Max. frequency -3dB	400 kHz	400 kHz	
Signal level	1 Vpp (±20 %)	HIGH: min. 2.5 V LOW: max. 0.5 V	
Short circuit proof	yes ¹⁾	yes ¹⁾	
Pulse rate	2048 ppr	2048 ppr	
SET input or SET button			
Input	active HIGH		
Input type	comparator		
Signal level	HIGH	min: 60 % of +V (supply voltage) max: +V	
	LOW	max: 25 % of +V (supply voltage)	
Input current	< 0.5 mA		
Min. pulse duration (SET)	10 ms		
Timeout after SET signal	14 ms		
<p>The encoder can be set to zero at any position by means of a HIGH signal on the SET input or by pressing the optional SET button (with a pencil, ball-point pen or similar).</p> <p>Other preset values can be factory-programmed. The SET input has a signal processing time of approx. 1 ms. Once the SET function has been triggered, the encoder requires an internal processing time of approx. 15 ms before the new position data can be read. During this time the status output is at LOW.</p> <p>If this input is not used, it should be connected to 0 V (Encoder ground GND) in order to avoid interferences.</p> <p>Note: In case of use of the BiSS interface, the SET function is carried out through BiSS.</p>			
DIR input			
<p>Direction input: A HIGH signal switches the direction of rotation from the default cw to ccw. This function can also be factory-programmed to be inverted. If DIR is changed when the device is already switched on, then this will be interpreted as an error.</p> <p>The LED will come ON and the status output will switch to LOW.</p> <p>If this input is not used, it should be connected to 0 V (Encoder ground GND) in order to avoid interferences.</p>			
Response time (DIR input)		1 ms	
Power-ON			
<p>After Power-ON the device requires a time of approx. 150 ms before valid data can be read.</p> <p>Hot plugging of the encoder should be avoided.</p>			
Approvals			
UL compliant in accordance with		File no. E224618	
CE compliant in accordance with			
	EMC Directive	2014/30/EU	
	RoHS Directive	2011/65/EU	

1) Short circuit to 0 V or to output, one channel at a time, supply voltage correctly applied.

Absolute encoders - singleturn

**Standard
Motor-Line, optical**

Sendix 5873 (tapered shaft)

SSI / BiSS + incremental

Terminal assignment

Interface	Type of connection	Features	Cable (isolate unused cores individually before initial start-up)
1, 2	E, F	SET, DIR, Status	Signal: 0 V +V C+ C- D+ D- SET DIR Stat N/C N/C N/C \perp
			Core color: WH BN GN YE GY PK BU RD BK - - - shield
5	E, F	SET, DIR, Status sensor output	Signal: 0 V +V C+ C- D+ D- SET DIR Stat N/C 0Vsens +Vsens \perp
			Core color: WH BN GN YE GY PK BU RD BK - GY-PK RD-BU shield
3, 4	E, F	SET, DIR, SinCos or incr. RS422	Signal: 0 V +V C+ C- D+ D- SET DIR A \bar{A} B \bar{B} \perp
			Core color: WH BN GN YE GY PK BU RD BK VT GY-PK RD-BU shield
6, 9, E	E, F	SinCos or incr. RS422 sensor output	Signal: 0 V +V C+ C- D+ D- A \bar{A} B \bar{B} 0Vsens +Vsens \perp
			Core color: WH BN GN YE GY PK BU RD BK VT GY-PK RD-BU shield
E	H	SinCos sensor output	Tangential cable, with Phoenix Contact connector (MC1.5/16-STF-3.81), 16-pin
			Signal: +V +Vsens 0 V 0Vsens N/C A \bar{A} B \bar{B} C+ C- D+ D- N/C N/C N/C Pin: 1 2 3 4 5 6 7 8 9 10 11 12 13 14 15 16
E	G	SinCos sensor output	Tangential cable, with Sub-D connector (male contact), 15-pin
			Signal: A 0 V B +V D+ - - C+ \bar{A} 0Vsens \bar{B} +Vsens D- - C- \perp Pin: 1 2 3 4 5 6 7 8 9 10 11 12 13 14 15
6, E	L	SinCos sensor output	PCB connector (male contact), 12-pin
			Signal: D- +V A C+ 0Vsens \bar{B} B 0 V C- \bar{A} +Vsens D+ Pin: 1a 1b 2a 2b 3a 3b 4a 4b 5a 5b 6a 6b
1, 2	L	SET, DIR	PCB connector (male contact), 12-pin
			Signal: D- +V - C+ DIR - - 0 V C- - SET D+ Pin: 1a 1b 2a 2b 3a 3b 4a 4b 5a 5b 6a 6b
3, 4	L	SET, DIR, SinCos	PCB connector (male contact), 12-pin
			Signal: D- +V A C+ DIR \bar{B} B 0 V C- \bar{A} SET D+ Pin: 1a 1b 2a 2b 3a 3b 4a 4b 5a 5b 6a 6b
5	L	sensor output	PCB connector (male contact), 12-pin
			Signal: D- +V - C+ 0Vsens - - 0 V C- - +Vsens D+ Pin: 1a 1b 2a 2b 3a 3b 4a 4b 5a 5b 6a 6b

- +V: Supply voltage encoder +V DC
- 0 V: Supply voltage encoder ground GND (0 V)
- 0 Vsens / +Vsens: Using the sensor outputs of the encoder, the voltage present can be measured and if necessary increased accordingly.
- C+, C-: Clock signal
- D+, D-: Data signal
- A, \bar{A} : Incremental output channel A (cosine)
- B, \bar{B} : Incremental output channel B (sine)
- SET: Set input
- DIR: Direction input
- Stat: Status output
- PH \perp : Plug connector housing (shield)

Top view of mating side, male contact base

Type of connection H
Phoenix Contact connector (MC1.5/16-STF-3.81), 16-pin



Type of connection G
Sub-D connector (male contact), double-row, 15-pin

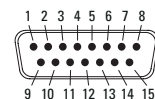

Type of connection L
FCI Minitek connector (male contact), double-row, 12-pin (98424-F52-12-LF)

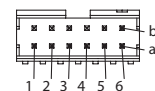

Terminal assignment cordset 8.0000.6D91.0002 or 8.0000.6D91.0008

PCB connector (female contacts), 12-pin / single-ended												
Pin:	1a	1b	2a	2b	3a	3b	4a	4b	5a	5b	6a	6b
Core color:	PK	BN	BU	GN	GY-PK	VT	BK	WH	YE	RD	RD-BU	GY

Absolute encoders - singleturn

Standard Motor-Line, optical	Sendix 5873 (tapered shaft)	SSI / BiSS + incremental
---	------------------------------------	---------------------------------

Dimensions tapered shaft version

Dimensions in mm [inch]

Flange with stator coupling, \varnothing 72 [2.83]

Flange type G

(with tapered shaft K and PCB connector)

- 1 Recommended torque for screw M6 (SW 4) 2.0 ^{+0.5} Nm
- 2 Recommended torque for central screw M5 (SW 4) 3.0 ^{+0.5} Nm (tapered shaft)
- 3 Sealing cap for tangential cable outlet

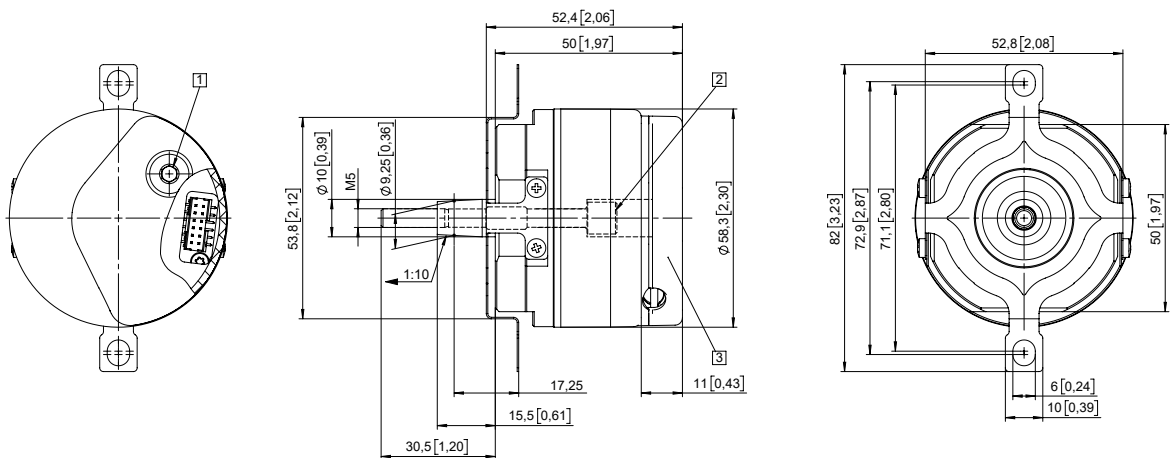

Flange with expanding coupling, \varnothing 65 [2.56"]

Flange type H

(with tapered shaft K and tangential cable)

- 1 Status-LED
- 2 SET button
- 3 Recommended torque for central screw M5 (SW 4) 3.0 ^{+0.5} Nm (tapered shaft)
- 4 Recommended torque for tightening screw M2.5 (SW 2) 1.0 Nm (expanding coupling)

