

# Absolute encoders - singleturn

Standard, ATEX/IECEX – zone 1/21 optical	Sendix 7053 / 7073 (shaft / hollow shaft)	SSI / BiSS
---	---	------------



The Sendix 7053 / 7073 absolute encoders – singleturn offer Ex protection in a compact 70 mm seawater durable aluminum housing, with an SSI or BiSS interface and optical sensor technology.

These shock and vibration-resistant encoders operate flexibly with a resolution of up to 17 bits; they are also available with axial and radial cable outlets.



Ex approval	Safety-Lock™	High rotational speed	High protection level	High shaft load capacity	Shock / vibration resistant	Magnetic field proof	Short-circuit proof	Reverse polarity protection	Optical sensor	Seawater durable

## Compact and safe

- Can be used even when space is tight.
- Minimal installation depth, diameter 70 mm.
- Compact cable outlet axial or radial.
- Can be operated in marine environments – housing and flange manufactured from seawater durable aluminum.
- Remains sealed even in harsh everyday use and ensures highest safety against field breakdowns (IP67 protection).

## Explosion protection

- “Flameproof-enclosure” version.
- ATEX with EC type examination certificate.
- IECEX with certificate of conformity (CoC).

<b>Order code</b>	<b>8.7053</b>	<b>.1</b>	<b>X</b>	<b>2</b>	<b>X</b>	<b>.XX</b>	<b>2</b>	<b>1</b>	<b>.XXXX</b>	
<b>Shaft version</b>	Type	a	b	c	d	e	f	g	h	i <sup>1)</sup>

**a Flange**  
1 = clamping / synchronous flange, ø 70 mm [2.76"]

**b Shaft (ø x L)**  
2 = 10 x 20 mm [0.39 x 0.79"], with flat  
1 = 12 x 25 mm [0.47 x 0.98"], with keyway  
for 4 x 4 mm [0.16 x 0.16"] key

**c Interface / supply voltage**  
2 = SSI, BiSS / 10 ... 30 V DC

**d Type of connection**  
1 = axial cable, 2 m [6.56'] PUR  
2 = radial cable, 2 m [6.56'] PUR  
A = axial cable, length > 2 m [6.56']  
B = radial cable, length > 2 m [6.56']

**e Code**  
B = SSI, binary  
C = BiSS, binary  
G = SSI, gray

**f Resolution<sup>2)</sup>**  
A = 10 bit  
1 = 11 bit  
2 = 12 bit  
3 = 13 bit  
4 = 14 bit  
7 = 17 bit

**g Inputs / outputs<sup>2)</sup>**  
2 = SET, DIR input  
additional status output

**h Options**  
1 = no option

**i Cable length in dm<sup>1)</sup>**  
0050 = 5 m [16.40']  
0100 = 10 m [32.81']  
0150 = 15 m [49.21']

*Optional on request*  
- special cable length  
- other resolutions  
- seawater resistant (stainless steel V4A)

1) Not applicable with connection types 1 and 2.  
2) Resolution, preset value and counting direction factory-programmable.

# Absolute encoders - singleturn

<b>Standard, ATEX/IECEX – zone 1/21 optical</b>	<b>Sendix 7053 / 7073 (shaft / hollow shaft)</b>	<b>SSI / BiSS</b>
---	--	-------------------

<b>Order code</b>	<b>8.7073</b>	<b>.XX2X.XX21.XXXX</b>			
<b>Hollow shaft</b>	Type	<b>a b c d e f g h i</b>	<b>i</b> <sup>1)</sup>		
<b>a</b> Flange	1 = with spring element, short 5 = with stator coupling, ø 65 mm [2.56"]	<b>e</b> Code	B = SSI, binary C = BiSS, binary G = SSI, gray	<b>i</b> Cable length in dm <sup>1)</sup>	0050 = 5 m [16.40'] 0100 = 10 m [32.81'] 0150 = 15 m [49.21']
<b>b</b> Blind hollow shaft (insertion depth max. 41.5 mm [1.63"])	1 = ø 12 mm [0.47"] 2 = ø 14 mm [0.55"]	<b>f</b> Resolution <sup>2)</sup>	A = 10 bit 1 = 11 bit 2 = 12 bit 3 = 13 bit 4 = 14 bit 7 = 17 bit	<i>Optional on request</i>	- special cable length - other resolutions - IP65 version for T6 - seawater resistant (stainless steel V4A)
<b>c</b> Interface / supply voltage	2 = SSI, BiSS / 10 ... 30 V DC	<b>g</b> Inputs / outputs <sup>2)</sup>	2 = SET, DIR input additional status output		
<b>d</b> Type of connection	1 = axial cable, 2 m [6.56'] PUR 2 = radial cable, 2 m [6.56'] PUR A = axial cable, length > 2 m [6.56'] B = radial cable, length > 2 m [6.56']	<b>h</b> Options	1 = no option		

<b>Mounting accessory for shaft encoders</b>		Order no.
<b>Coupling</b>	bellows coupling ø 19 mm [0.75"] for shaft 10 mm [0.39"]	<b>8.0000.1102.1010</b>

Further accessories can be found in the accessories section or in the accessories area of our website at: [kuebler.com/accessories](http://kuebler.com/accessories).  
Additional connectors can be found in the connection technology section or in the connection technology area of our website at: [kuebler.com/connection\\_technology](http://kuebler.com/connection_technology).

## Technical data

Explosion protection Sendix 7053	
<b>ATEX</b>	
<b>EC type-examination certificate</b>	PTB09 ATEX 1106 X
<b>Category (gas)</b>	⊕ II 2 G Ex d IIC T4 - T6 Gb
<b>Category (dust)</b>	⊕ II 2D Ex tb IIIC T135°C - T85°C Db
<b>Relevant standards</b> ATEX guideline 94/9/EC	EN 60079-0:2012; EN 60079-1:2014; EN 60079-31:2009
<b>IECEX</b>	
<b>Certificate of Conformity (CoC)</b>	IECEX PTB 13.0026 X
<b>Category (gas)</b>	Ex d IIC T4 - T6 Gb
<b>Category (dust)</b>	Ex tb IIIC T135°C - T85°C Db
<b>Relevant standards</b>	IEC 60079-0:2011; IEC 60079-1:2014; IEC 60079-31:2008

Explosion protection Sendix 7073	
<b>ATEX</b>	
<b>EU type-examination certificate</b>	IBExU 15 ATEX 1091 X
<b>Category (gas)</b>	⊕ II 2 G Ex db IIC T4/120°C (T4)/T6 Gb
<b>Category (dust)</b>	⊕ II 2 D Ex tb IIIC T135°C - T85°C Db
<b>Relevant standards</b> ATEX guideline 2014/34/EU	EN 60079-0:2012 + A11:2013; EN 60079-1:2014; EN 60079-31:2014
<b>IECEX</b>	
<b>Certificate of Conformity (CoC)</b>	IECEX IBE 15.0020 X
<b>Category (gas)</b>	Ex db IIC T4/120°C (T4)/T6 Gb
<b>Category (dust)</b>	Ex tb IIIC T135°C - T85°C Db
<b>Relevant standards</b>	IEC 60079-0:2011; IEC 60079-1:2014; IEC 60079-31:2013

Electrical characteristics	
<b>Supply voltage</b>	10 ... 30 V DC
<b>Current consumption (no load)</b>	max. 45 mA
<b>Reverse polarity protection for supply voltage</b>	yes
<b>Short-circuit proof outputs</b>	yes <sup>3)</sup>

EMC	
<b>Relevant standards</b>	EN 55011 class B:2009 / A1:2010 EN 61000-6-2:2005 / AC:2005 EN 61000-6-3:2007 / A1:2011 EN 61326-1:2013

1) Not applicable with connection types 1 and 2.  
2) Resolution, preset value and counting direction factory-programmable.  
3) Short-circuit with 0 V or output, only one channel at a time, supply voltage correctly applied.

# Absolute encoders - singleturn

<b>Standard, ATEX/IECEX – zone 1/21 optical</b>	<b>Sendix 7053 / 7073 (shaft / hollow shaft)</b>	<b>SSI / BiSS</b>
---	--	-------------------

Mechanical characteristics		
<b>Maximum speed</b>	shaft hollow shaft	6000 min <sup>-1</sup> (continuous) 3000 min <sup>-1</sup> (continuous)
<b>Starting torque</b> - at 20 °C [68 °F]		< 0.05 Nm
<b>Mass moment of inertia</b>		4.0 x 10 <sup>-6</sup> kgm <sup>2</sup>
<b>Load capacity of shaft</b>	radial axial	80 N 40 N
<b>Weight</b>		approx. 1.5 kg [52.91 oz]
<b>Protection</b> acc. to EN 60529		IP67
<b>Ambient temperature</b>		-40 °C ... +60 °C [-40 °F ... +140 °F] Please note the specifications for temperature class in EC type-examination certificate!
<b>Material</b>	shaft flange / housing cable	stainless steel seawater durable Al, type AlSiMgMn (EN AW-6082) PUR
<b>Shock resistance</b> to EN/IEC 60068-2-27		2500 m/s <sup>2</sup> , 6 ms
<b>Vibration resistance</b> to EN/IEC 60068-2-6		100 m/s <sup>2</sup> , 55 ... 2000 Hz

SSI interface		
<b>Output driver</b>		RS485 transceiver type
<b>Permissible load / channel</b>		max. +/- 20 mA
<b>Signal level</b>	HIGH LOW at I <sub>Load</sub> = 20 mA	typ 3.8 V typ 1.3 V
<b>Resolution</b>		10 ... 14 bit and 17 bit
<b>Code</b>		binary or gray
<b>SSI clock rate</b>		50 kHz ... 2 MHz
<b>Data refresh rate</b>	ST resolution ≤ 14 bit ST resolution ≥ 15 bit	< 1 μs 4 μs
<b>Monoflop time</b>		≤ 15 μs
<b>Note:</b> if clock starts cycling within monoflop time a second data transfer starts with the same data. If clock starts cycling after monoflop time, the data transfer starts with updated values. The update rate depends on clock speed, data length and monoflop time.		

BiSS interface		
<b>Output driver</b>		RS485 transceiver type
<b>Permissible load / channel</b>		max. +/- 20 mA
<b>Signal level</b>	HIGH LOW at I <sub>Load</sub> = 20 mA	typ 3.8 V typ 1.3 V
<b>Resolution</b>		10 ... 14 bit and 17 bit
<b>Code</b>		binary
<b>Clock rate</b>		up to 10 MHz
<b>Max. update rate</b>		< 10 μs, depends on the clock rate and the data length
<b>Data refresh rate</b>	ST resolution ≤ 14 bit ST resolution 17 bit	≤ 1 μs 2.4 μs
<b>Note:</b>	<ul style="list-style-type: none"> <li>- bidirectional, factory programmable parameters are: resolution, code, direction, alarms and warnings</li> <li>- CRC data verification</li> </ul>	

Status output	
<b>Output driver</b>	open collector, internal pull-up resistor 22 kOhm
<b>Permissible load</b>	max. 20 mA
<b>Signal level</b>	HIGH +V LOW < 1 V
<b>Active at</b>	LOW
The status output serves to display various alarm or error messages. The status output is HIGH (open collector with internal pull-up 22 kOhm) in normal operation.	

SET input	
<b>Input</b>	HIGH active
<b>Input type</b>	comparator
<b>Signal level</b> (+V = supply voltage)	HIGH min. 60% of +V max. +V LOW max. 25% of +V
<b>Input current</b>	< 0.5 mA
<b>Min. pulse duration (SET)</b>	10 ms
<b>Timeout after SET signal</b>	14 ms

The encoder can be set to zero at any position by means of a HIGH signal on the SET input. Other preset values can be factory-programmed. The SET input has a signal delay time of approximately 1 ms. Once the SET function has been triggered, the encoder requires an internal processing time of approximately 15 ms before the new position data can be read. If this input is not used, it should be connected to 0 V (Encoder ground GND) in order to avoid interferences.

DIR input	
Direction input: A HIGH signal switches the direction of rotation from the default cw to ccw. This inverted function can also be factory-programmed. If DIR is reversed when the device is already switched on, this will be interpreted as an error. The status output switches to LOW. If this input is not used, it should be connected to 0 V (Encoder ground GND) in order to avoid interferences.	
<b>Response time (DIR input)</b>	1 ms

Power-ON	
After Power-ON the device requires a time of approx. 150 ms before valid data can be read.	
Hot plugging of the encoder should be avoided.	

Approvals		
<b>CE compliant</b> in accordance with	EMC Directive	2014/30/EU
	RoHS Directive	2011/65/EU
	ATEX Directive	2014/34/EU (for Ex 2/22 variants)

# Absolute encoders - singleturn

**Standard, ATEX/IECEx – zone 1/21  
optical**

**Sendix 7053 / 7073 (shaft / hollow shaft)**

**SSI / BiSS**

## Terminal assignment

Interface	Type of connection	Features	Cable (isolate unused cores individually before initial start-up)												
			Signal:	0 V	+V	C+	C-	D+	D-	SET	DIR	Stat	⊥	⊥	
2	1, 2, A, B	SET, DIR	Core marking:	1	2	3	4	5	6	7	8	9	YE/GN	shield	

+V: Supply voltage encoder +V DC

0 V: Supply voltage encoder ground GND (0 V)

C+, C-: Clock signal

D+, D-: Data signal

SET: Set input

DIR: Direction input

Stat: Status output

⊥: Protective earth

## Dimensions shaft version

Dimensions in mm [inch]

### Clamping / synchronous flange, ø 70 [2.76]

#### Shaft type 1 with axial cable outlet

1 9 x M4, 10 [0.39] deep

2 Keyway for DIN 6885-A-4x4x25 key

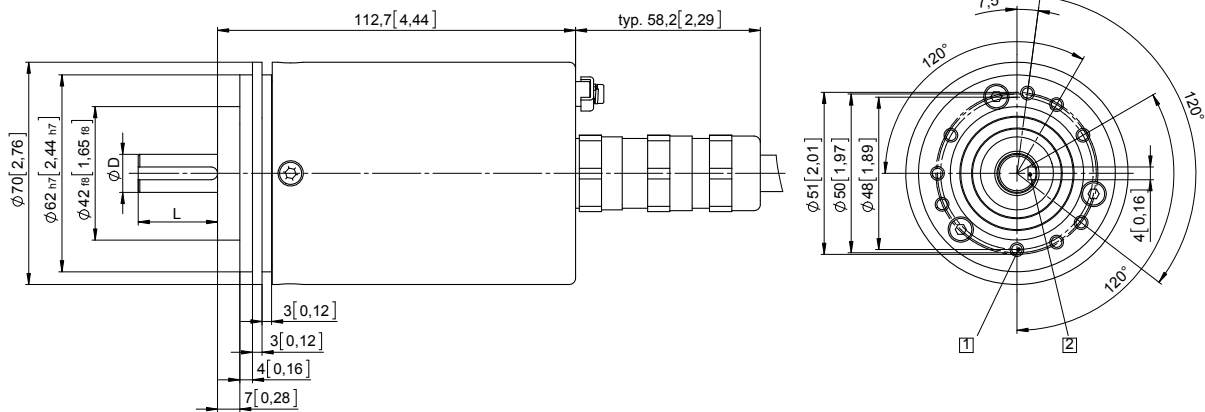

D	Fit	L
12 [0.47]	g6	25 [0.98]

### Clamping / synchronous flange, ø 70 [2.76]

#### Shaft type 2 with radial cable outlet

1 9 x M4, 10 [0.39] deep

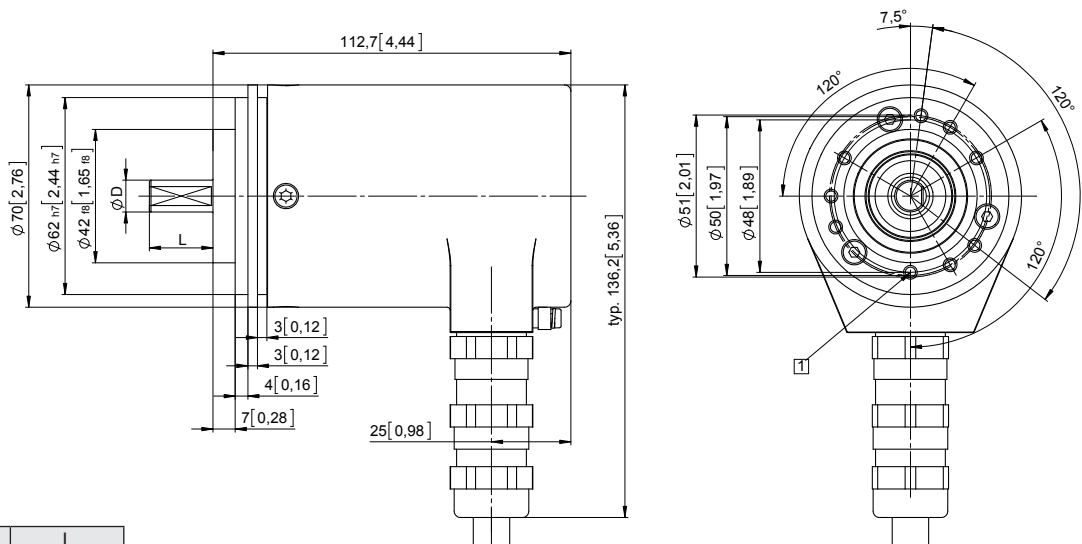

D	Fit	L
10 [0.39]	f7	20 [0.79]

