

Absolute encoders - singleturn

Standard, ATEX/IECEX – mining optical	Sendix 7158 / 7178 (shaft / hollow shaft)	CANopen
---------------------------------------	---	---------



The Sendix 7158 / 7178 absolute singleturn encoders in a compact 70 mm stainless-steel housing, with a CANopen interface and optical sensor technology have an ATEX/IECEX mining approval.

These shock and vibration-resistant encoders operate flexibly with a resolution of up to 16 bits; they are also available with axial and radial cable outlets.



Ex approval	Safety-Lock™	High rotational speed	High protection level	High shaft load capacity	Shock / vibration resistant	Magnetic field proof	Short-circuit proof	Reverse polarity protection	Optical sensor

Compact and safe

- Can be used even when space is tight.
- Minimal installation depth, diameter 70 mm.
- Compact cable outlet axial or radial.
- Remains sealed even in harsh everyday use and ensures highest safety against field breakdowns (IP67 protection).

Explosion protection

- Mining approval.
- “Flame-proof enclosure” construction.
- ATEX with EC type examination certificate.
- IECEx with certificate of conformity (CoC).

Order code	8.7158	. 2X 2X . 21 11 . XXXX
Shaft version	Type	Type

- a** Flange
2 = clamping / synchronous flange, ø 70 mm [2.76"]
- b** Shaft (ø x L)
2 = 10 x 20 mm [0.39 x 0.79"], with flat
1 = 12 x 25 mm [0.47 x 0.98"], with keyway for 4 x 4 mm [0.16 x 0.16"] key
- c** Interface / supply voltage
2 = CANopen DS301 V4.02 / 10 ... 30 V DC

- d** Type of connection
1 = axial cable, 2 m [6.56'] PUR
2 = radial cable, 2 m [6.56'] PUR
A = axial cable, length > 2 m [6.56']
B = radial cable, length > 2 m [6.56']
- e** Fieldbus profile
21 = CANopen

- f** Cable length in dm ¹⁾
0050 = 5 m [16.40']
0100 = 10 m [32.81']
0150 = 15 m [49.21']

Optional on request
- special cable length

Order code	8.7178	. XX 2X . 21 11 . XXXX
Hollow shaft	Type	Type

- a** Flange
2 = with spring element, short
6 = with stator coupling, ø 65 mm [2.56"]
- b** Blind hollow shaft
(insertion depth max. 41.5 mm [1.63"])
1 = ø 12 mm [0.47"]
2 = ø 14 mm [0.55"]
- c** Interface / supply voltage
2 = CANopen DS301 V4.02 / 10 ... 30 V DC

- d** Type of connection
1 = axial cable, 2 m [6.56'] PUR
2 = radial cable, 2 m [6.56'] PUR
A = axial cable, length > 2 m [6.56']
B = radial cable, length > 2 m [6.56']
- e** Fieldbus profile
21 = CANopen

- f** Cable length in dm ¹⁾
0050 = 5 m [16.40']
0100 = 10 m [32.81']
0150 = 15 m [49.21']

Optional on request
- special cable length

1) Not applicable with connection types 1 and 2.

Absolute encoders - singleturn

Standard, ATEX/IECEX – mining optical

Sendix 7158 / 7178 (shaft / hollow shaft)

CANopen

Technical data

Explosion protection 7158

ATEX	
EC type-examination certificate	IBExU 14 ATEX 1047 X
Category	⊕ I M2 Ex d I/IIC T4 - T6 Mb
Relevant standards ATEX guideline 94/9/EC	EN 60079-0:2012; EN 60079-1:2007
IECEX	
Certificate of Conformity (CoC)	IECEX IBE 14.0023 X
Category	Ex d I/IIC T4 - T6 Mb
Relevant standards ATEX guideline 94/9/EC	IEC 60079-0:2011; IEC 60079-1:2007

Mechanical characteristics

Maximum speed	shaft	6000 min ⁻¹ (continuous)
	hollow shaft	3000 min ⁻¹ (continuous)
Starting torque – at 20 °C [68 °F]		< 0.05 Nm
Mass moment of inertia		4.0 x 10 ⁻⁶ kgm ²
Load capacity of shaft	radial	80 N
	axial	40 N
Weight		approx. 2.8 kg [98.77 oz]
Protection acc. to EN 60529		IP67
Ambient temperature		-40 °C ... +60 °C [-4 °F ... +140 °F] Please note the specifications for temperature class in EC type-examination certificate!
Material	shaft	stainless steel
	flange / housing	stainless steel
	cable	PUR
Shock resistance		
	acc. to EN/IEC 60068-2-27	1000 m/s ² , 6 ms
Vibration resistance		
	acc. to EN/IEC 60068-2-6	100 m/s ² , 55 ... 2000 Hz

Electrical characteristics

Supply voltage	10 ... 30 V DC
Current consumption (no load)	max. 90 mA
Reverse polarity protection for supply voltage	yes

EMC

Relevant standards	EN 55011 class B:2009 / A1:2010 EN 61000-6-2:2005 / AC:2005 EN 61000-6-3:2007 / A1:2011 EN 61326-1:2013
---------------------------	--

Explosion protection 7178

ATEX	
EU type-examination certificate	IBExU 15 ATEX 1057 X
Category	⊕ I M2 Ex db I/IIC T4/120°C (T4)/T6 Mb
Relevant standards ATEX guideline 2014/34/EU	EN 60079-0:2012 + A11:2013; EN 60079-1:2014
IECEX	
Certificate of Conformity (CoC)	IECEX IBE 15.0019 X
Category	Ex db I/IIC T4/120°C (T4)/T6 Mb
Relevant standards	IEC 60079-0:2011; IEC 60079-1:2014

Approvals

CE compliant in accordance with		
EMC Directive	2014/30/EU	
RoHS Directive	2011/65/EU	
ATEX Directive	2014/34/EU (for Ex 2/22 variants)	

Absolute encoders - singleturn

Standard, ATEX/IECEX – mining optical	Sendix 7158 / 7178 (shaft / hollow shaft)	CANopen
--	--	----------------

Interface characteristics CANopen	
Resolution	1 ... 65536 (16 bit), scalable default: 8192 (13 bit)
Interface	CAN high-speed acc. to ISO 11898, Basic- and Full-CAN, CAN specification 2.0 B
Protocol	CANopen profile DS406 V3.2 with manufacturer-specific add-ons
Baud rate	10 ... 1000 kbit/s software configurable
Node address	1 ... 127 software configurable
Switchable termination	software configurable

General information about CANopen

The CANopen encoders support the latest CANopen communication profile according to DS301 V4.02 .

In addition, device-specific profiles like the encoder profile DS406 V3.2 are available.

The following operating modes may be selected: Polled Mode, Cyclic Mode, Sync Mode and a High Resolution Sync Protocol. Moreover, scale factors, preset values, limit switch values and many other additional parameters can be programmed via the CANbus. When switching the device on, all parameters are loaded from an EEPROM, where they were saved previously to protect them against power-failure.

As output values **position**, **speed**, **acceleration** as well as the **working area status** may be combined freely as PDO (PDO mapping)

CANopen communication profile DS301 V4.02

Among others, the following functionality is integrated:

Class C2 functionality

- NMT slave.
- Heartbeat protocol.
- High resolution sync protocol.
- Identity object.
- Error behavior object.
- Variable PDO mapping self-start programmable (power on to operational), 3 Sending PDO's.
- Node address, baud rate and CANbus termination programmable.

CANopen encoder profile DS406 V3.2

The following parameters can be programmed:

- Event mode.
- Units for speed selectable (steps/sec or min⁻¹).
- Factor for speed calculation (e.g. measuring wheel circumference)
Integration time for speed value of 1...32.
- 2 work areas with 2 upper and lower limits and the corresponding output states.
- Variable PDO mapping of position, speed, acceleration, working area status.
- Extended failure management for position sensing with integrated temperature control.
- User interface with visual display of bus and failure status - 3 LED's.
- Optional - 32 CAMs programmable.
- Customer-specific memory - 16 Bytes.

Terminal assignment

Interface	Type of connection	Cable (isolate unused cores individually before initial start-up)								
		Signal:	0 V	+V	CAN_H	CAN_L	CAN_GND	CAN_H	CAN_L	CAN_GND
2	1, 2, A, B	Core marking:	1	2	4	5	6	7	8	9

Absolute encoders - singleturn

Standard, ATEX/IECEx – mining optical

Sendix 7158 / 7178 (shaft / hollow shaft)

CANopen

Dimensions shaft version

Dimensions in mm [inch]

Clamping / synchronous flange, \varnothing 70 [2.76]
Shaft type 1 with axial cable outlet

- 1 9 x M4, 10 [0.39] deep
- 2 Keyway for DIN 6885-A-4x4x25 key

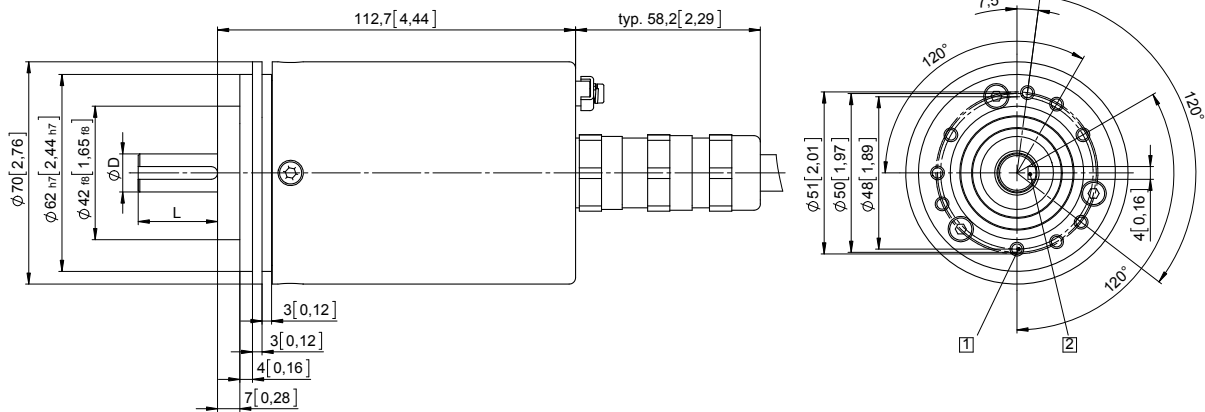

D	Fit	L
12 [0.47]	g6	25 [0.98]

Clamping / synchronous flange, \varnothing 70 [2.76]
Shaft type 2 with radial cable outlet

- 1 9 x M4, 10 [0.39] deep

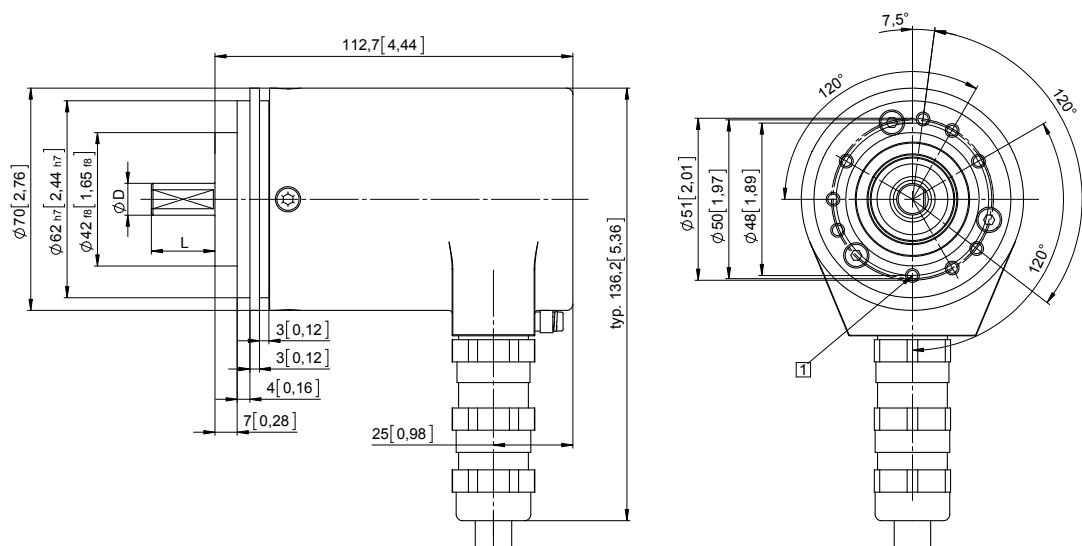

D	Fit	L
10 [0.39]	f7	20 [0.79]

Absolute encoders - singleturn

Standard, ATEX/IECEX – mining optical	Sendix 7158 / 7178 (shaft / hollow shaft)	CANopen
--	--	----------------

Dimensions hollow shaft version

Dimensions in mm [inch]

Flange with spring element, short Flange type 2

- 1 9 x M4, 10 [0.39] deep
- 2 Slot spring element, recommendation: torque pin DIN 7, \varnothing 4 [0.16]
- 3 Recommended torque for the clamping ring 2.5 Nm

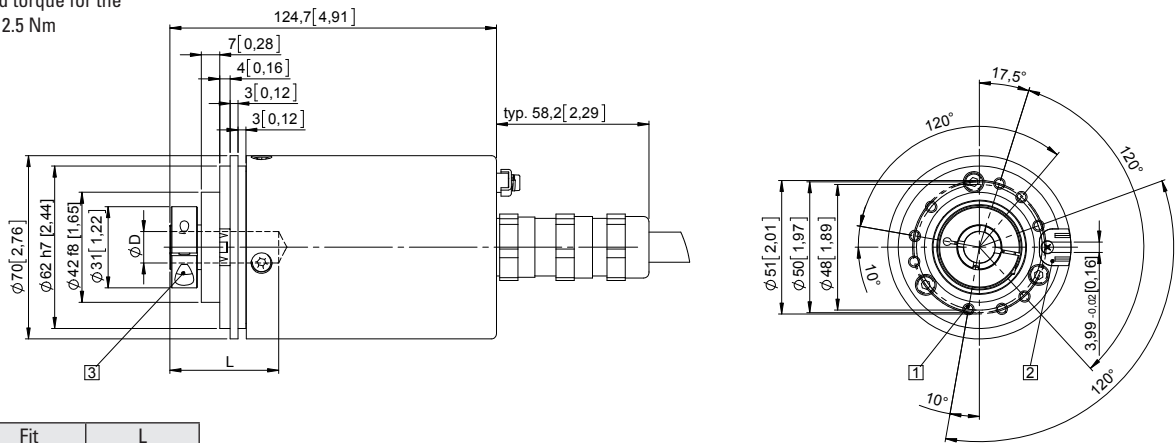

D	Fit	L
12 [0.47]	H7	41.5 [1.63"]
14 [0.55]	H7	41.5 [1.63"]

L = insertion depth max. blind hollow shaft

Flange with stator coupling, \varnothing 65 [2.56] Flange type 6

- 1 Recommended torque for the clamping ring 2.5 Nm

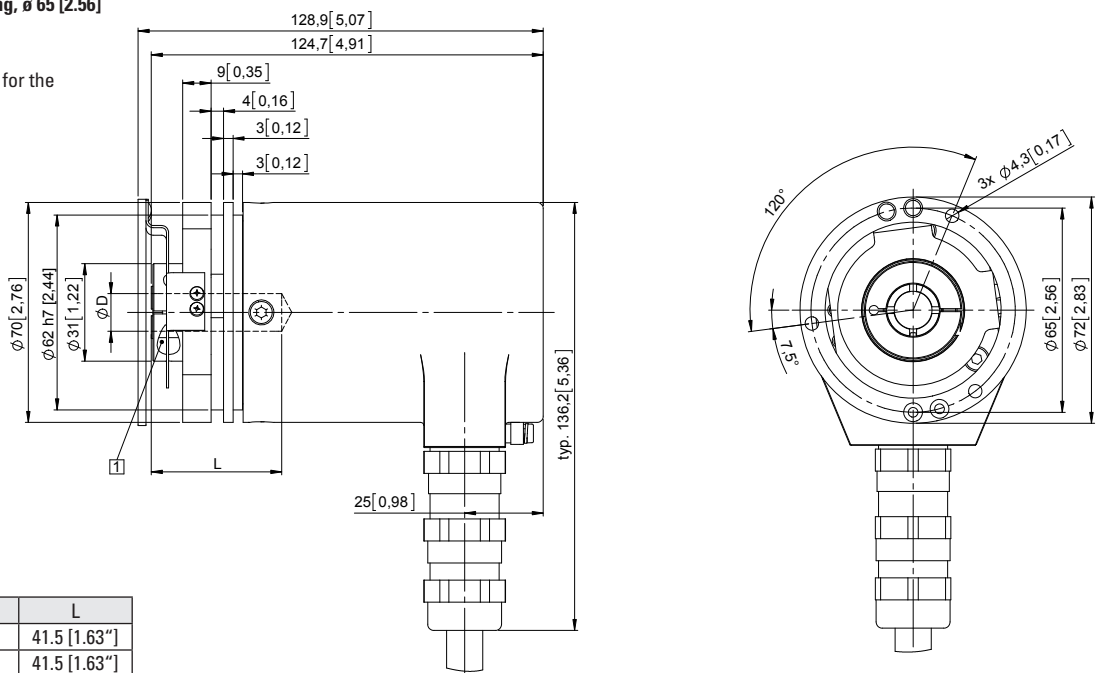

D	Fit	L
12 [0.47]	H7	41.5 [1.63"]
14 [0.55]	H7	41.5 [1.63"]

L = insertion depth max. blind hollow shaft