

Linear measuring technology

Draw-wire encoder A50	Performance-Line	Measuring length max. 1.25 m
------------------------------	-------------------------	-------------------------------------



The draw-wire mechanics A50 boast both a compact design and high dynamics.

The draw-wire mechanics may be equipped with encoders with an analog, incremental or absolute output. The maximum measuring length is 1.25 m.



Max. acceleration 300 m/s ²	Long service life	Wide temperature range	High protection level IP	Reverse polarity protection	Integrated swivel	Interchangeable installation

Robust

- The titanium-anodized aluminum housing and the stainless steel wires allow for using the mechanics even in harsh conditions.
- Wear-free wire exit thanks to special plain bearing guide.
- Various wire types and wire fastenings.

Versatile

- High traverse speed, up to 10 m/s.
- High acceleration, up to 300 m/s².
- Quick fastening by means of 2 screws.
- Various connection possibilities available.
- Scalable analog output with limit switch function.
- Interchangeable encoders (Interchangeable installation).

Order code with encoder (incremental, absolute)

D8.X|A1.XXXX.XX|XX.XXXX

a
b
c
d
e
f

<p>a <i>Mechanics</i></p> <p>2 = interchangeable installation ¹⁾</p> <p>6 = fixed installation ²⁾</p> <p>b <i>Measuring range</i></p> <p>0025 = 250 mm</p> <p>0050 = 500 mm</p> <p>0100 = 1000 mm</p> <p>0125 = 1250 mm</p>	<p>c <i>Encoder used</i></p> <p>36 = Sendix 3610, incremental</p> <p>M3 = Sendix M3663, absolute, SSI</p> <p>F3 = Sendix F3663, absolute, SSI</p> <p>M8 = Sendix M3668, absolute, CANopen</p> <p>Sendix M3668, absolute, SAE J1939</p> <p>Sendix M3668, absolute, IO-Link</p> <p>F8 = Sendix F3668, absolute, CANopen</p>	<p>d <i>Output circuit</i></p> <p>depends on the encoder used</p> <p>e <i>Type of connection</i></p> <p>depends on the encoder used</p> <p>f <i>Resolution / Protocol / Options</i></p> <p>depends on the encoder used</p>	<p><i>Optional on request</i></p> <ul style="list-style-type: none"> - Other measuring ranges - Other wire fastening: M4 thread, eyelet or carabiner ring - Modified cable and/or connector orientation - Modified cable outlet direction - Sensor protection level IP67 - Improved linearity (0.02 %)
-----------------------------------------------------------------------------------------------------------------------------------------------------------------------------------------------------------------------------------------------------------------	----------------------------------------------------------------------------------------------------------------------------------------------------------------------------------------------------------------------------------------------------------------------------------------------------------------------------------	-------------------------------------------------------------------------------------------------------------------------------------------------------------------------------------------------------------------------------------------------	--------------------------------------------------------------------------------------------------------------------------------------------------------------------------------------------------------------------------------------------------------------------------------------------------------------------------------------------------------------------

Standard resolutions for draw-wire with incremental encoder Sendix 3610			
Drum circumference [mm]	125	125	125
Pulses / revolution [ppr]	125	1250	2500
Pulses / mm	1	10	20
Resolution [mm]	1	0.1	0.05

Standard resolutions for draw-wire with absolute encoder Sendix F3663/M3663 (12 bit ST) or F3668/M3668 (12 bit ST, programmable via bus)	
Drum circumference [mm]	125
Pulses / revolution [ppr]	4096
Pulses / mm	32.8
Resolution [mm]	0.03

1) Draw-wire mechanics with standard flange. The encoder can be replaced by the customer.
 2) The encoder can only be replaced at the factory.

Linear measuring technology

Draw-wire encoder A50

Performance-Line

Measuring length max. 1.25 m

Recommended standard variants (with incremental, absolute encoder)

Order no. draw-wire encoder	Mounted encoder	Interface	Power supply	Type of connection	Resolution / Protocol	Option
D8.6A1.xxxx.3642.1250	3610 (8.3610.4342.1250)	Push-pull with inverted signal	8 ... 30 V DC	radial cable, 2 m	1250 ppr	-
D8.6A1.xxxx.M324.G222	Sendix M3663 (8.M3663.4124.G222)	SSI	10 ... 30 V DC	radial M12 connector	4096 ppr / SSI-Gray-Code	-
D8.6A1.xxxx.M824.2122	Sendix M3668 (8.M3668.4124.2122)	CANopen	10 ... 30 V DC	radial M12 connector	CANopen encoder profile DS406 V4.0	-
D8.6A1.xxxx.M834.3222	Sendix M3668 (8.M3668.4134.3222)	SAE J1939	10 ... 30 V DC	radial M12 connector	SAE J1939	-
D8.6A1.xxxx.M844.4122	Sendix M3668 (8.M3668.4144.4122)	IO-Link	18 ... 30 V DC	radial M12 connector	IO-Link	-

Other variants (with absolute encoder)

Order no. draw-wire encoder	Mounted encoder	Interface	Power supply	Type of connection	Resolution / Protocol	Option
D8.6A1.xxxx.F321.G222	Sendix F3663 (8.F3663.4121.G222)	SSI	10 ... 30 V DC	tangential cable, 1 m	4096 ppr / SSI-Gray-Code	-
D8.6A1.xxxx.F821.2122	Sendix F3668 (8.F3668.4121.2122)	CANopen	10 ... 30 V DC	tangential cable, 1 m	CANopen encoder profile DS406 V3.2	-

Order code with encoder (analog, scalable with limit switch function)

D8. **A**1 . **XXXX** . **M1****X****X** . **XXXX**

a
b
c
d
e
f

- | | | | |
|-----------------------------------------------------------------------------------------------------------------------------------------------------------------------------------------------------------------------------------------------|-----------------------------------------------------------------------------------|----------------------------------------------------------------------------------------------------------------------------------------------------------------------------------------------------------------------------------------|------------------------------------------------------------------------------------------------------------------------------------------------------------------------------------------------------------------------------------------------------------------------------------------------------------------------------------------------------------------------|
| <p>a <i>Mechanics</i>
2 = interchangeable installation ¹⁾
6 = fixed installation ²⁾</p> <p>b <i>Measuring range</i>
0025 = 250 mm
0050 = 500 mm
0100 = 1000 mm
0125 = 1250 mm</p> | <p>c <i>Encoder used</i>
M1 = Sendix M3661, absolute ³⁾</p> | <p>d <i>Output circuit</i>
depends on the encoder used</p> <p>e <i>Type of connection</i>
depends on the encoder used</p> <p>f <i>Resolution / Protocol / Options</i>
depends on the encoder used</p> | <p><i>Optional on request</i></p> <ul style="list-style-type: none"> - Other measuring ranges - Other wire fastening:
M4 thread, eyelet or carabiner ring - Modified cable and/or connector orientation - Modified cable outlet direction - Sensor protection level IP67 - Improved linearity (0.02 %) |
|-----------------------------------------------------------------------------------------------------------------------------------------------------------------------------------------------------------------------------------------------|-----------------------------------------------------------------------------------|----------------------------------------------------------------------------------------------------------------------------------------------------------------------------------------------------------------------------------------|------------------------------------------------------------------------------------------------------------------------------------------------------------------------------------------------------------------------------------------------------------------------------------------------------------------------------------------------------------------------|

Recommended standard variants (with analog encoder, scalable with limit switch function)

Order no. draw-wire encoder	Mounted encoder	Interface	Power supply	Type of connection	Resolution / Protocol	Option
D8.6A1.xxxx.M134.3612	Sendix M3661 (8.M3661.4134.3612)	Analog, 4 ... 20 mA	10 ... 30 V DC	M12-Stecker radial	12 Bit / 4 ... 20 mA	scalable without limit switch function ⁴⁾
D8.6A1.xxxx.M144.4612	Sendix M3661 (8.M3661.4144.4612)	Analog, 0 ... 10 V	15 ... 30 V DC	M12-Stecker radial	12 Bit / 0 ... 10 V	scalable without limit switch function ⁴⁾
D8.6A1.xxxx.M134.3512	Sendix M3661 (8.M3661.4134.3512)	Analog, 4 ... 20 mA	10 ... 30 V DC	M12-Stecker radial	12 Bit / 4 ... 20 mA	scalable with limit switch function ⁵⁾
D8.6A1.xxxx.M144.4512	Sendix M3661 (8.M3661.4144.4512)	Analog, 0 ... 10 V	15 ... 30 V DC	M12-Stecker radial	12 Bit / 0 ... 10 V	scalable with limit switch function ⁵⁾

Order code with analog sensor (scaled to measuring range)

D8. **3A**1 . **XXXX** . **XXX****X** . **0000**

b
c
d

- | | | |
|------------------------------------------------------------------------------------------------------------------|-------------------------------------------------------------------------------------------------------------------------------------------------------------------------------------------------------------------------------------------------------------------------------------------------|-----------------------------------------------------------------------------------------------------------------------------------------------------------------------------------------------------------------------------------------------------------------------------------------------------------------------------------------------------------------------------------------------------------------|
| <p>b <i>Measuring range</i>
0025 = 250 mm
0050 = 500 mm
0100 = 1000 mm
0125 = 1250 mm</p> | <p>c <i>Analog sensor output / supply voltage</i>
A11 = 4 ... 20 mA / 12 ... 30 V DC
A22 = 0 ... 10 V / 12 ... 30 V DC
A33 = potentiometer 1 kΩ / max. 30 V DC</p> <p>d <i>Type of connection</i>
1 = axial cable, 2 m PVC
3 = axial M12 connector, 4-pin</p> | <p><i>Optional on request</i></p> <ul style="list-style-type: none"> - Other measuring ranges - Other wire fastening:
M4 thread, eyelet or carabiner ring - Modified cable and/or connector orientation - Modified cable outlet direction - Sensor protection level IP67 - Increased temperature range -40 °C ... +85 °C and -20 °C ... +120 °C |
|------------------------------------------------------------------------------------------------------------------|-------------------------------------------------------------------------------------------------------------------------------------------------------------------------------------------------------------------------------------------------------------------------------------------------|-----------------------------------------------------------------------------------------------------------------------------------------------------------------------------------------------------------------------------------------------------------------------------------------------------------------------------------------------------------------------------------------------------------------|

1) Draw-wire mechanics with standard flange. The encoder can be replaced by the customer.
 2) The encoder can only be replaced at the factory.
 3) With ccw option.
 4) Delivery condition: scaled to measuring range.
 Description for scaling and limit switch function see data sheet M3661.
 5) Delivery condition: unscaled.
 Description for scaling and limit switch function see data sheet M3661.

Linear measuring technology

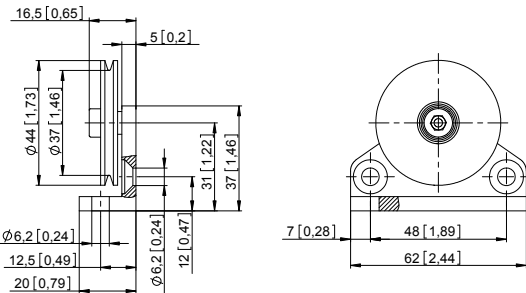
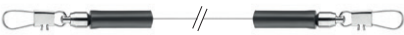
Draw-wire encoder A50	Performance-Line	Measuring length max. 1.25 m
Accessories for draw-wire encoder	Dimensions in mm [inch]	Order no.
Guide pulley 	Technical data: - mounting bracket (anodized alum.) - guide pulley (plastic POM) - ball bearing (type 696-2R5)	Scope of delivery: - 2 x countersunk screws for lateral fixing - 2 x hexagonal screws for fixing on a flat surface
		8.0000.7000.0045
Extension cable (further on request) 	0.5 m with clip 1.0 m with clip 2.0 m with clip	8.0000.7000.0051 8.0000.7000.0052 8.0000.7000.0054
Cables and connectors		Order no.
Preassembled cables	M12 female connector with coupling nut, 5-pin, A coded, straight single ended 2 m [6.56'] PVC cable	05.00.6081.2211.002M
Connectors	M12 female connector with coupling nut, 5-pin, A coded, straight (metal) M12 female connector with coupling nut, 5-pin, A coded, straight (metal/plastic) M12 female connector with coupling nut, 5-pin, A coded, right-angle (plastic)	8.0000.5116.0000 05.B-8151-0/9 05.B-8251-0/9

Further Kübler cables and connectors can be found at: kuebler.com/connection-technology

Linear measuring technology

Draw-wire encoder A50	Performance-Line	Measuring length max. 1.25 m
------------------------------	-------------------------	-------------------------------------

Technical data

Mechanical characteristics (draw-wire mechanics)				
Measuring range	250 mm	500 mm	1250 mm	
Extension force	F_{min}	6.8 N	3.4 N	4.1 N
	F_{max}	7.9 N	4.0 N	5.4 N
Speed max.	8 m/s	8 m/s	10 m/s	
Acceleration max.	200 m/s ²	200 m/s ²	300 m/s ²	
Linearity (of the measuring range)				
with analog sensor	±0.15 %	±0.1 %	±0.1 %	
with encoder	±0.05 %	±0.05 %	±0.05 %	
	±0.02 % ¹⁾	±0.02 % ¹⁾	±0.02 % ¹⁾	
Weight	approx. 330 g [11.64 oz] (depending on the sensor / encoder used)			
Material	housing	titanium-anodized aluminum		
	wire	stainless steel ø 0.5 mm (other wire types on request)		
Protection acc. to EN 60529	IP65 (sensor)			

Electrical characteristics (digital output)
The electrical characteristics of the draw-wire mechanics with digital output can be found in the data sheets of the encoders.

Approvals
CE compliant in accordance with
EMC Directive 2014/30/EU
RoHS Directive 2011/65/EU

Electrical characteristics (analog sensor, scaled to measuring range)			
Version	A22	A11	A33
Analog output	0 ... 10 V	4 ... 20 mA	potentiometer
Output	0 ... 10 V / galv. isolated, 4 conductors	4 ... 20 mA / 2 conductors	1 kΩ
Supply voltage	12 ... 30 V DC	12 ... 30 V DC	max. 30 V DC
Recommended slider current	–	–	< 1 μA
Max. current consumption	22.5 mA (no load)	50 mA	–
Reverse polarity protection	yes	yes	–
Working temperature	-20 °C ... +85 °C [-4 °F ... +185 °F]	-20 °C ... +85 °C [-4 °F ... +185 °F]	-20 °C ... +85 °C [-4 °F ... +185 °F]
	-40 °C ... +85 °C [-40 °F ... +185 °F] ²⁾	-40 °C ... +85 °C [-40 °F ... +185 °F] ²⁾	-20 °C ... +120 °C [-4 °F ... +248 °F] ²⁾

Terminal assignment (analog sensor)

Analog sensor A11 (4 ... 20 mA)			R/I converter				
		Signal:	+V	n.c.	I _{out}	n.c.	
	Cable ¹⁾	Core color:	BN	WH	BU	BK	
	M12 connector, 4-pin	Pin:	1	2	3	4	
Analog sensor A22 (0 ... 10 V DC)			R/U converter				
		Signal:	+V	U _{out}	0 V	0 V _{out}	
	Cable ¹⁾	Core color:	BN	WH	BU	BK	
	M12 connector, 4-pin	Pin:	1	2	3	4	
Analog sensor A33 (Potentiometer 1 kΩ)			Potentiometer				
		Signal:	+V	Out	0 V	n.c.	
	Cable ¹⁾	Core color:	BN	WH	BU	BK	
	M12 connector, 4-pin	Pin:	1	2	3	4	

Top view of mating side, male contact base

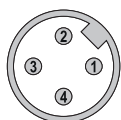

M12 connector, 4-pin

1) On request for encoder version: **36** (see order code **b**).
2) Optional on request.

Linear measuring technology

Draw-wire encoder A50	Performance-Line	Measuring length max. 1.25 m
------------------------------	-------------------------	-------------------------------------

Technology in detail

Operating principle

Construction
The core of a draw-wire device is a drum mounted on bearings, onto which a wire is wound. Winding takes place via a spring-loaded device.

Note
Exceeding the maximum extension length of the draw-wire will lead to damage to the wire and the mechanics.

Wire fastenings

Clip	M4 thread	Eyelet	Carabiner ring
D8.xx 1 .xxxx.xxxx	D8.xx A .xxxx.xxxx	D8.xx J .xxxx.xxxx	D8.xx M .xxxx.xxxx
ball-bearing swivel (no torsion of the measuring wire during installation)			
rubber stopper			
measuring wire			

Linear measuring technology

Draw-wire encoder A50

Performance-Line

Measuring length max. 1.25 m

Technology in detail

Extension wire

For optimum use of the measuring range by extending the wire length, e. g. to allow realizing a pre-extension in the application. Especially combined with analog interfaces.



Wire types

- V2A, \varnothing 0.5 mm (standard)
- Optional on request:
 - V4A, \varnothing 0.51 mm
 - Coramid, \varnothing 0.6 mm
 - V4A plastic coated, 1.0 mm (V4A = \varnothing 0.81 mm)



Application-specific installation possibilities

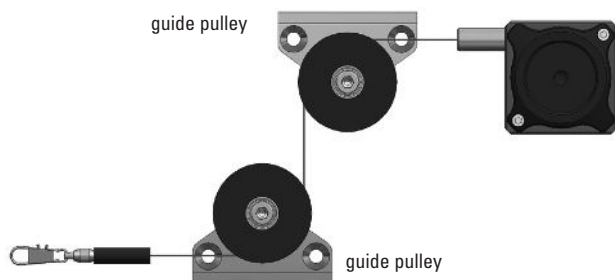

Individual wire outlet

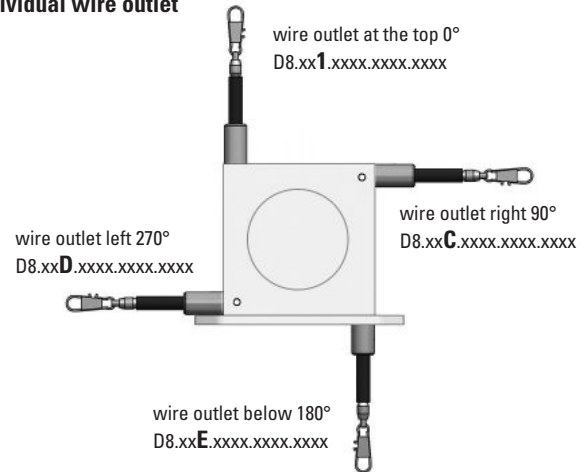

Individual cable / connector orientation on request

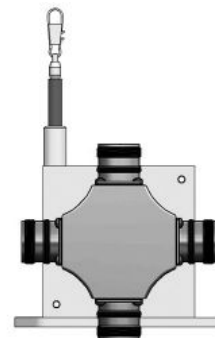

Linear measuring technology

Draw-wire encoder A50 Performance-Line Measuring length max. 1.25 m

Dimensions

Dimensions in mm [inch]

Draw-wire mechanics with encoder Fixed installation

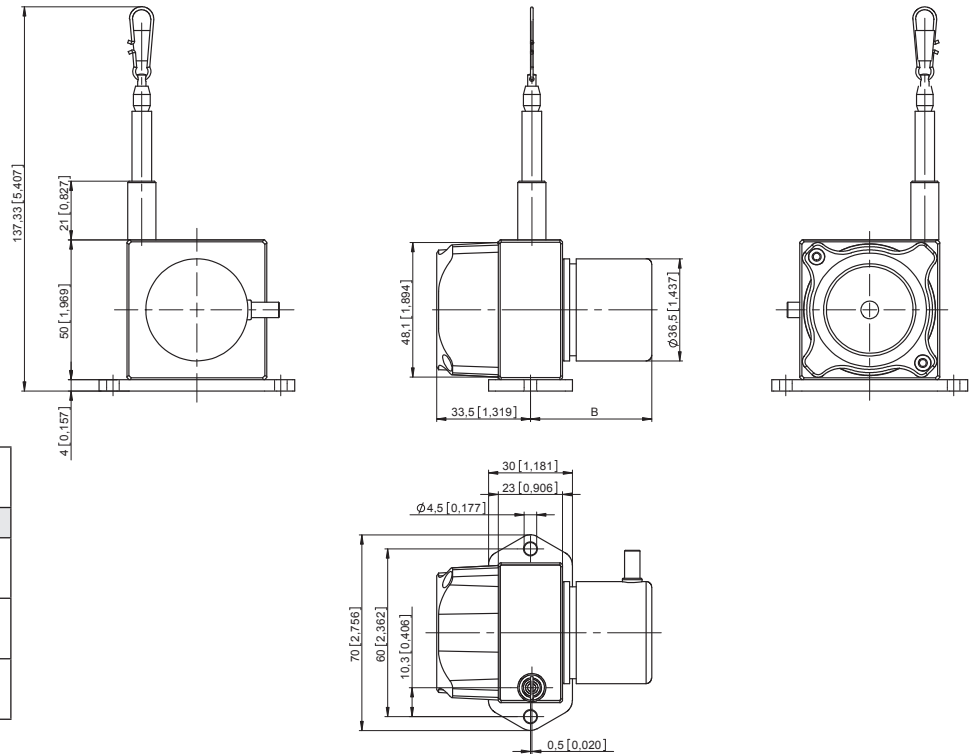

Dimension B depends on the encoder used

Encoder	B
Sendix incremental 3610 D8.6A1.xxxx.36xx.xxxx	43.00 [1.69]
Sendix absolute M366x D8.6A1.xxxx.Mxxx.xxxx	62.45 [2.46]
Sendix absolute F366x D8.6A1.xxxx.Fxxx.xxxx	51.20 [2.02]

Draw-wire mechanics with encoder Interchangeable installation

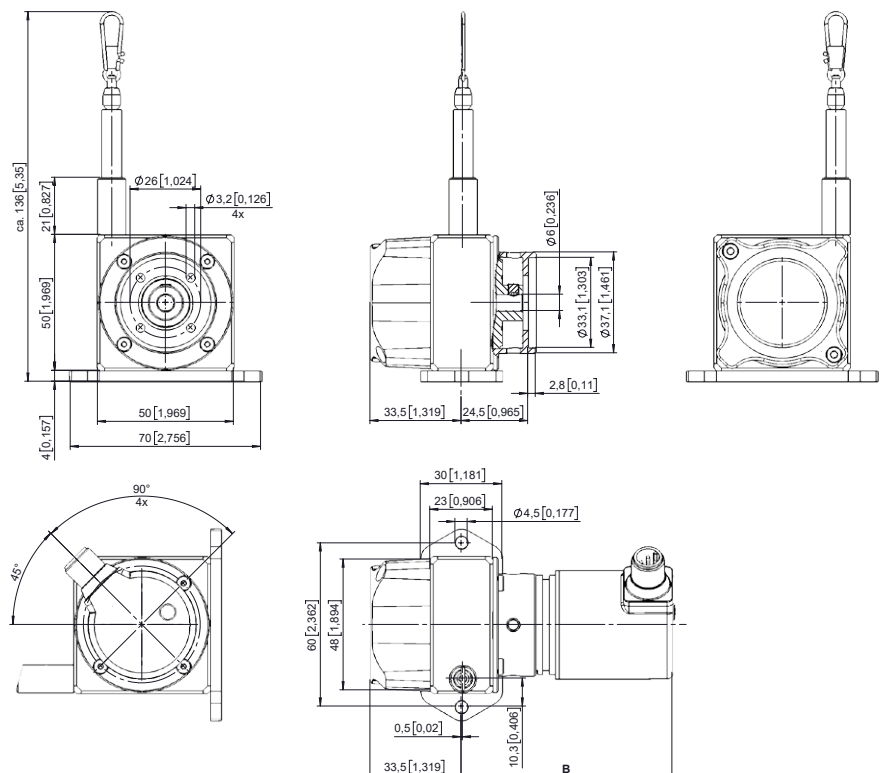

Dimension B depends on the encoder used

Encoder	B
Sendix incremental 3610 D8.6A1.xxxx.36xx.xxxx	59.30 [2.33]
Sendix absolute M366x D8.6A1.xxxx.Mxxx.xxxx	77.55 [3.05]
Sendix absolute F366x D8.6A1.xxxx.Fxxx.xxxx	67.50 [2.66]

Linear measuring technology

Draw-wire encoder A50

Performance-Line

Measuring length max. 1.25 m

Dimensions

Dimensions in mm [inch]

Draw-wire mechanics with analog sensor
(scaled on measuring range)

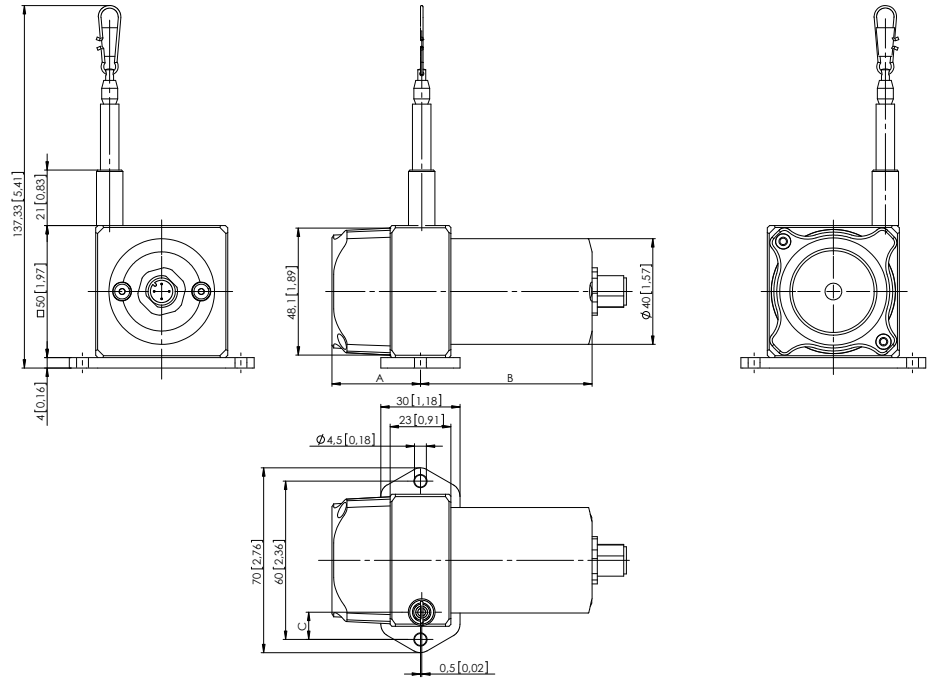

Sensor type	Measuring length	A	B	C
Potentiometer	250 mm	26.5 [1.04]	65 [2.56]	21.30 [0.84]
	500 mm	26.5 [1.04]	65 [2.56]	12.75 [0.50]
	1250 mm	33.5 [1.32]	65 [2.56]	10.30 [0.41]