

Linear measuring technology

Draw-wire encoder B75	Compact-Line	Measuring length max. 3 m
------------------------------	---------------------	----------------------------------



The draw-wire mechanics B75 can be used up to a measuring length of 3 meters.

These draw-wire mechanics may be combined with the proven Kübler Sendix encoders with incremental or absolute interface, as well as with analog sensors, which are also available in redundant version.



Wide temperature range	High protection level	Reverse polarity protection	Interchangeable installation	Flat design	Ventilation/water drain	Variable mounting

Compact and versatile

- Compact housing.
- Variable mounting possibilities.
- Low-wear wire exit.
- Closable ventilation and water drain holes.
- Scalable analog interface with limit switch function.
- Various fieldbus interfaces.
- Redundant Sensors.

Order code with encoder (incremental, absolute)

D8.15 **03** . **XXXX** . **XXXX**
Type a b c d e

- | | | | |
|---|--|---|---|
| <p>a <i>Measuring range</i>
03 = 3000 mm</p> | <p>b <i>Encoder used</i>
 Z2 = Sendix 5000, incremental
 M3 = Sendix M5863, absolute
 F3 = Sendix F5863, absolute
 63 = Sendix 5863, absolute
 M8 = Sendix M5868, absolute
 F8 = Sendix F5868, absolute
 68 = Sendix 5868, absolute</p> | <p>c <i>Output circuit</i>
depends on the encoder used</p> <p>d <i>Type of connection</i>
depends on the encoder used</p> | <p>e <i>Resolution / Protocol / Options</i>
depends on the encoder used</p> <p><i>Optional on request</i>
- Other measuring ranges</p> |
|---|--|---|---|

Standard resolutions for draw-wire with incremental encoder Sendix 5000			
Drum circumference [mm]	200	200	200
Pulses / revolution [ppr]	200	2000	4000
Pulses / mm	1	10	20
Resolution [mm]	1	0.1	0.05

Standard resolutions for draw-wire with absolute encoder M5863 (12 bit ST) or M5868 (12 bit ST, programmable via bus)	
Drum circumference [mm]	200
Pulses / revolution [ppr]	4096
Pulses / mm	20.5
Resolution [mm]	0.05

Recommended standard variants (with incremental, absolute encoder)

Order no. draw-wire encoder	Mounted encoder	Interface	Power supply	Type of connection	Resolution / Protocol	Option
D8.1503.2Z54.2000	Sendix 5000 (8.5000.B154.2000)	Push-pull with inverted signal	10 ... 30 V DC	radial M12 connector	2000 ppr	-
D8.1503.M324.G222	Sendix M5863 (8.M5863.4124.G222)	SSI	10 ... 30 V DC	radial M12 connector	4096 ppr / SSI-Gray-Code	-
D8.1503.M824.2122	Sendix M5868 (8.M5868.4124.2122)	CANopen	10 ... 30 V DC	radial M12 connector	CANopen encoder profile DS406 V4.0	-

Linear measuring technology

Draw-wire encoder B75

Compact-Line

Measuring length max. 3 m

Other variants

Order no. draw-wire encoder	Mounted encoder	Interface	Power supply	Type of connection	Resolution / Protocol	Option
D8.1503.F326.G223	Sendix F5863 (8.F5863.2126.G223)	SSI	10 ... 30 V DC	1 x radial M12 connector	4096 ppr / SSI-Gray-Code	SET button + status LED
D8.1503.6326.G223	Sendix 5863 (8.5863.2126.G223)	SSI	10 ... 30 V DC	1 x radial M12 connector	4096 ppr / SSI-Gray-Code	SET button + status LED
D8.1503.F82E.2123	Sendix F5868 (8.F5868.212E.2123)	CANopen	10 ... 30 V DC	1 x radial M12 connector	CANopen encoder profile DS406 V3.2	SET button
D8.1503.6822.2123	Sendix 5868 (8.5868.2122.2123)	CANopen	10 ... 30 V DC	2 x radial M12 connector	CANopen encoder profile DS406 V3.2	SET button
D8.1503.M834.3222	Sendix M5868 (8.M5868.4134.3222)	SAE J1939	10 ... 30 V DC	1 x radial M12 connector	SAE J1939	-
D8.1503.M844.4122	Sendix M5868 (8.M5868.4144.4122)	IO-Link	18 ... 30 V DC	1 x radial M12 connector	IO-Link	-
D8.1503.6832.3113	Sendix 5868 (8.5868.2132.3113)	PROFIBUS	10 ... 30 V DC	3 x radial M12 connector	Profibus-DP V0 encoder profile Class 2	SET button
D8.1503.68B2.B212	Sendix 5868 (8.5868.21B2.B212)	EtherCAT	10 ... 30 V DC	3 x radial M12 connector	EtherCAT with CoE 3.2.10	-
D8.1503.F8CN.C122	Sendix F5868 (8.F5868.21CN.C122)	PROFINET IO	10 ... 30 V DC	3 x axial M12 connector	PROFINET Encoder-Profil Version 4.2	-
D8.1503.F8AN.A222	Sendix F5868 (8.F5868.21AN.A222)	EtherNet/IP	10 ... 30 V DC	3 x axial M12 connector	EtherNet/IP	-

Order code with encoder (analog, scalable with limit switch function)

D8.15 **03** . **M1XX** . **XXXX**
Type **a** **b** **c** **d** **e**

- a** Measuring range
03 = 3000 mm
 - b** Encoder used
M1 = Sendix M5861, absolute ¹⁾
 - c** Output circuit
depends on the encoder used
 - d** Type of connection
depends on the encoder used
 - e** Resolution / Protocol / Options
depends on the encoder used
- Optional on request*
- Other measuring ranges

Recommended standard variants (with encoder analog, scalable with limit switch function)

Order no. draw-wire encoder	Mounted encoder	Interface	Power supply	Type of connection	Resolution / Protocol	Option
D8.1503.M134.3512	Sendix M5861 (8.M5861.4134.3512)	Analog, 4 ... 20 mA	10 ... 30 V DC	radial M12 connector	12 Bit / 4 ... 20 mA	scalable with limit switch function ²⁾
D8.1503.M144.4512	Sendix M5861 (8.M5861.4144.4512)	Analog, 0 ... 10 V	15 ... 30 V DC	radial M12 connector	12 Bit / 0 ... 10 V	scalable with limit switch function ²⁾
D8.1503.M134.3612	Sendix M5861 (8.M5861.4134.3612)	Analog, 4 ... 20 mA	10 ... 30 V DC	radial M12 connector	12 Bit / 4 ... 20 mA	scalable without limit switch function ²⁾
D8.1503.M144.4612	Sendix M5861 (8.M5861.4144.4612)	Analog, 0 ... 10 V	15 ... 30 V DC	radial M12 connector	12 Bit / 0 ... 10 V	scalable without limit switch function ²⁾

Order code with analog sensor (scaled to measuring range)

D8.35 **03** . **XXX** **2** . **0000**
Type **a** **b** **c** **e**

- a** Measuring range
03 = 3000 mm
 - b** Single sensor / Supply voltage
A11 = 4 ... 20 mA / 10 ... 30 V DC
A22 = 0 ... 10 V DC / 15 ... 28 V DC
A33 = potentiometer 10 kΩ / max. 30 V DC
 - c** Type of connection
2 = radial M12 connector
(wire outlet direction)
4-pin for sensor type A11 ... A33
8-pin for sensor type R11 ... R33
 - e** *Optional on request*
- Other measuring ranges
- Redundant sensors / Supply voltage*
R11 = 2 x 4 ... 20 mA / 10 ... 30 V DC
R33 = 2 x potentiometer 10 kΩ / max. 30 V DC

1) With ccw option.

2) Delivery condition: unscaled.
Description for scaling and limit switch function see data sheet M5861.

Linear measuring technology

Draw-wire encoder B75	Compact-Line	Measuring length max. 3 m
------------------------------	---------------------	----------------------------------

Accessories for draw-wire encoder	Dimensions in mm [inch]	Order no.
-----------------------------------	-------------------------	-----------

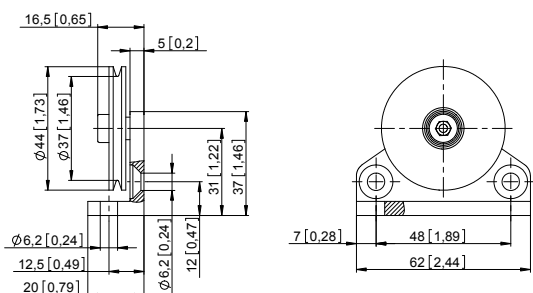
Guide pulley 	<p>Technical data:</p> <ul style="list-style-type: none"> - mounting bracket (anodized alum.) - guide pulley (plastic POM) - ball bearing (type 696-2R5) <p>Scope of delivery:</p> <ul style="list-style-type: none"> - 2 x countersunk screws for lateral fixing - 2 x hexagonal screws for fixing on a flat surface 	8.0000.7000.0045
		

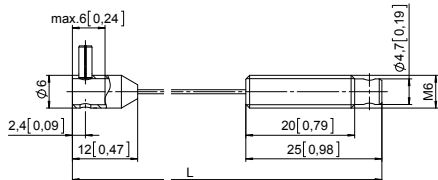
Extension cable (further on request) 		<p>Steel wire 2 m [6.56'] 8.0000.7000.0033</p> <p>Steel wire 5 m [16.40'] 8.0000.7000.0034</p> <p>Steel wire 10 m [32.81'] 8.0000.7000.0035</p> <p>Paraleine 2 m [6.56'] 8.0000.7000.0032</p>
--	--	---

Cables and connectors	Order no.
-----------------------	-----------

Preassembled cables	<p>M12 female connector with coupling nut, 4-pin, A coded, straight single ended 2 m [6.56'] PUR cable 05.00.6061.6211.002M</p> <p>M12 female connector with coupling nut, 5-pin, A coded, straight single ended 2 m [6.56'] PVC cable 05.00.6081.2211.002M</p> <p>M12 male connector with external thread, 4-pin, D coded, straight single ended 2 m [6.56'] PUR cable 05.00.6031.4411.002M</p> <p>M12 female connector with coupling nut, 8-pin, A coded, straight single ended 2 m [6.56'] PVC cable 05.00.6041.8211.002M</p>	
Connectors	<p>M12 female connector with coupling nut, 5-pin, A coded, straight (metal) 8.0000.5116.0000</p> <p>M12 female connector with coupling nut, 5-pin, A coded, straight (metal/plastic) 05.B-8151-0/9</p> <p>M12 female connector with coupling nut, 5-pin, A coded, right-angle (plastic) 05.B-8251-0/9</p>	

Further Kübler cables and connectors can be found at: kuebler.com/connection-technology

Linear measuring technology

Draw-wire encoder B75	Compact-Line	Measuring length max. 3 m
------------------------------	---------------------	----------------------------------

Technology in detail

Operating principle

Construction

The core of a draw-wire device is a drum mounted on bearings, onto which a wire is wound. Winding takes place via a spring-loaded device.

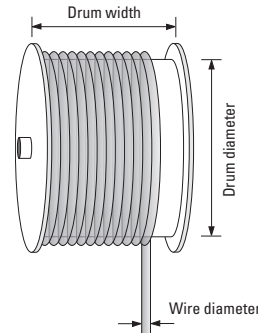

Note

Exceeding the maximum extension length of the draw-wire will lead to damage to the wire and the mechanics.

Dimensions

Dimensions in mm [inch]

Draw-wire mechanics with encoder

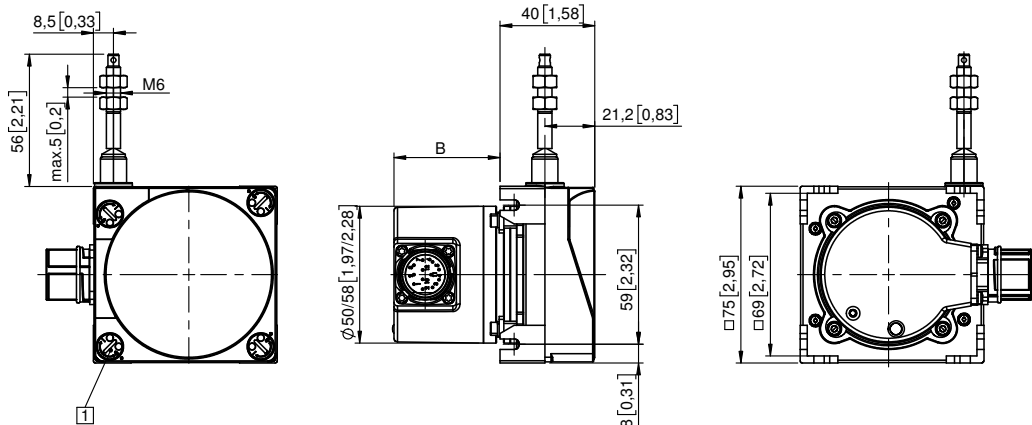

1 4 x closable ventilation and water drain holes

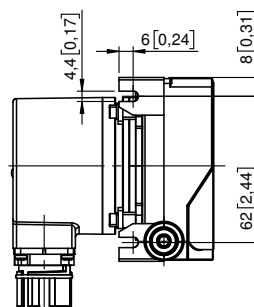

Dimension B depends on the encoder used	
Encoder	B
Sendix incremental (5000) D8.1503.xxxx.2Zxx.xxxx	43.00 [1.69]
Sendix absolute (F5863) D8.1503.xxxx.F3xx.xxxx	55.50 [2.19]
Sendix absolute (5863) D8.1503.xxxx.63xx.xxxx	55.50 [2.19]
Sendix absolute (F5868, CANopen) D8.1503.xxxx.F8xx.21xx	65.50 [2.58]
Sendix absolute (F5868, EtherNet/IP) D8.1503.xxxx.F8xx.A2xx	65.50 [2.58]
Sendix absolute (5868) D8.1503.xxxx.68xx.xxxx	83.20 [3.28]
Sendix absolute (M586x) D8.1503.xxxx.Mxxx.xxxx	50.55 [1.99]

Linear measuring technology

Draw-wire encoder B75

Compact-Line

Measuring length max. 3 m

Dimensions

Dimensions in mm [inch]

Draw-wire mechanics with analog sensor (A11, A22, A33) scaled on measuring range

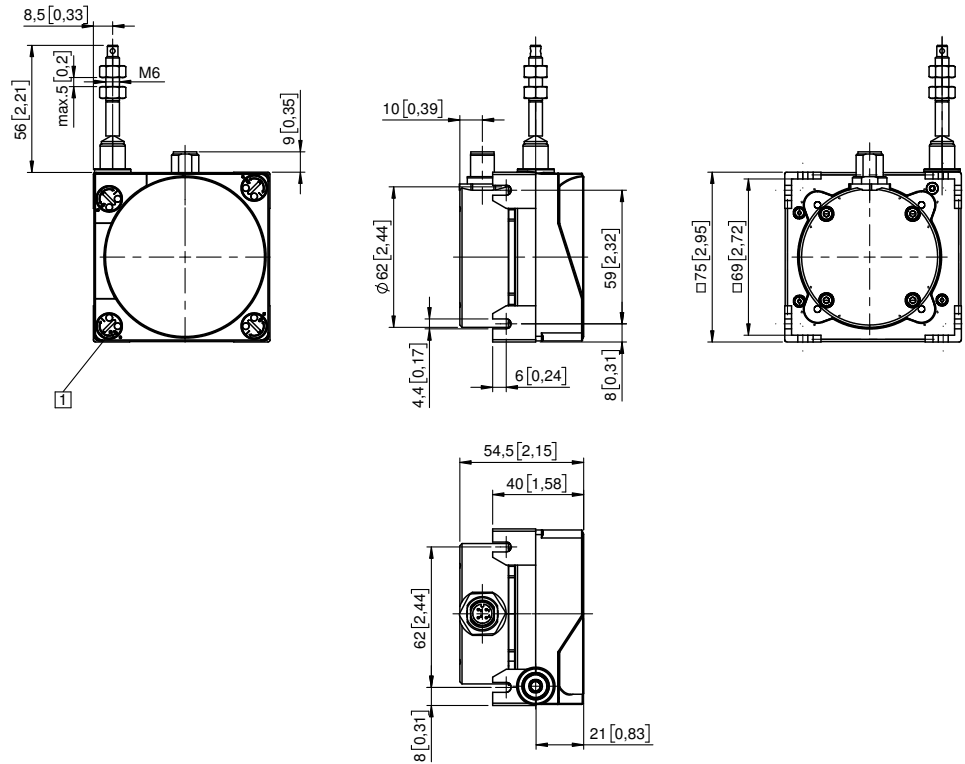

1 4 x closable ventilation and water drain holes

Draw-wire mechanics with analog sensor (redundant – R11, R33) scaled on measuring range

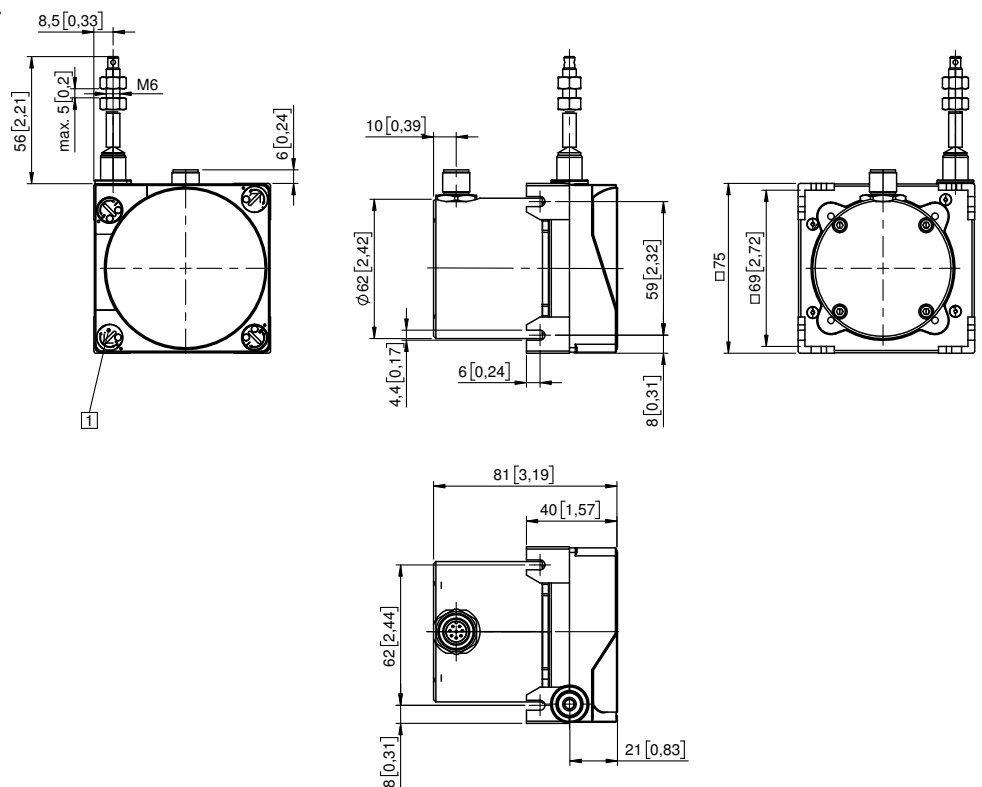

1 4 x closable ventilation and water drain holes