

Linear measuring technology

Draw-wire encoder C100	Base-Line	Measuring length max. 5 m
-------------------------------	------------------	----------------------------------



The draw wire system C100 is more than a sensor for determining length-related position data. Variants with integrated inclinometer and redundant interfaces offer versatile application possibilities. The contactless magnetic position scanning, a high IP67 protection level and the wider temperature range round off the product.



Analog output



Wide temperature range



High protection level



Shock / vibration resistant



Redundancy



Relay output



Switching outputs

Characteristics

- Measuring length up to 5 m.
- Integrated inclinometer.
- Redundant sensors.
- Different types of sensors (analog, incremental, CANopen, relay output, switch output).
- Linearity up to $\pm 0.1\%$ of the measuring range.
- High protection level IP67 and wide temperature range from -40 °C ... $+85\text{ °C}$.

Advantages

- The suitable measuring length for every application.
- Cost, space and installation work saving.
- For even higher plant availability.
- Simple selection and fast installation.
- High accuracy at economic prices.
- Reliability and long service life for outdoor applications.

Order code with analog sensor

D8 . C100 . XXXX . XXX 1 . 1 000

a Measuring length

0100 = 1 m
0200 = 2 m
0300 = 3 m
0400 = 4 m
0500 = 5 m

b Single sensor

A11 = 4 ... 20 mA
A22 = 0 ... 10 V
A44 = 0.5 ... 4.5 V

Redundat sensor

R11 = 2 x 4 ... 20 mA
R22 = 2 x 0 ... 10 V
R44 = 2 x 0.5 ... 4.5 V

Crossed signals

R1C = 4 ... 20 mA / 20 ... 4 mA
R2C = 0 ... 10 V / 10 ... 0 V
R4C = 0,5 ... 4,5 V / 4,5 ... 0,5 V

c Type of connection

1 = M12 connector, 5-pin

Order code with CANopen and inclinometer

D8 . C100 . XXXX . XXX 1 . 1 X 00

a Measuring length

0100 = 1 m
0200 = 2 m
0300 = 3 m
0400 = 4 m
0500 = 5 m

b Sensor type

RC1 = CANopen redundant
RCT = CANopen redundant, with termination resistor 120 Ω

c Type of connection

1 = M12 connector, 5-pin

d Inclinometers

0 = none
1 = 1 inclinometer
2 = 2 inclinometers

Stock types

D8.C100.0500.RC11.1000

Linear measuring technology

Draw-wire encoder C100	Base-Line	Measuring length max. 5 m
-------------------------------	------------------	----------------------------------

Order code with incremental output	<table border="1" style="width: 100%; border-collapse: collapse;"> <tr> <td style="width: 15%; text-align: center;">D8.</td> <td style="width: 15%; text-align: center;">C100</td> <td style="width: 15%; text-align: center;">.XXXX</td> <td style="width: 15%; text-align: center;">.XXX</td> <td style="width: 15%; text-align: center;">X</td> <td style="width: 15%; text-align: center;">.1</td> <td style="width: 15%; text-align: center;">000</td> </tr> <tr> <td></td> <td></td> <td style="text-align: center;">a</td> <td style="text-align: center;">b</td> <td style="text-align: center;">c</td> <td></td> <td></td> </tr> </table>	D8.	C100	.XXXX	.XXX	X	.1	000			a	b	c		
D8.	C100	.XXXX	.XXX	X	.1	000									
		a	b	c											
a <i>Measuring length</i> 0100 = 1 m 0200 = 2 m 0300 = 3 m 0400 = 4 m 0500 = 5 m	b <i>Sensor type</i> I11 = incremental AB, 512 ppr I12 = incremental ABZ, 512 ppr I21 = incremental AB, 1024 ppr I22 = incremental ABZ, 1024 ppr	c <i>Type of connection</i> 1 = M12 connector, 5-pin 3 = radial cable, 2 m [6.56']													

Order code with relays output	<table border="1" style="width: 100%; border-collapse: collapse;"> <tr> <td style="width: 15%; text-align: center;">D8.</td> <td style="width: 15%; text-align: center;">C100</td> <td style="width: 15%; text-align: center;">.XXXX</td> <td style="width: 15%; text-align: center;">.RL1</td> <td style="width: 15%; text-align: center;">1</td> <td style="width: 15%; text-align: center;">.1</td> <td style="width: 15%; text-align: center;">000</td> </tr> <tr> <td></td> <td></td> <td style="text-align: center;">a</td> <td style="text-align: center;">b</td> <td style="text-align: center;">c</td> <td></td> <td></td> </tr> </table>	D8.	C100	.XXXX	.RL1	1	.1	000			a	b	c		
D8.	C100	.XXXX	.RL1	1	.1	000									
		a	b	c											
a <i>Measuring length</i> 0100 = 1 m 0200 = 2 m 0300 = 3 m 0400 = 4 m 0500 = 5 m	b <i>Sensor type</i> RL1 = relay output	c <i>Type of connection</i> 1 = M12 connector, 5-pin													

Order code with switch output	<table border="1" style="width: 100%; border-collapse: collapse;"> <tr> <td style="width: 15%; text-align: center;">D8.</td> <td style="width: 15%; text-align: center;">C100</td> <td style="width: 15%; text-align: center;">.XXXX</td> <td style="width: 15%; text-align: center;">.SW3</td> <td style="width: 15%; text-align: center;">4</td> <td style="width: 15%; text-align: center;">.1</td> <td style="width: 15%; text-align: center;">000</td> </tr> <tr> <td></td> <td></td> <td style="text-align: center;">a</td> <td style="text-align: center;">b</td> <td style="text-align: center;">c</td> <td></td> <td></td> </tr> </table>	D8.	C100	.XXXX	.SW3	4	.1	000			a	b	c		
D8.	C100	.XXXX	.SW3	4	.1	000									
		a	b	c											
a <i>Measuring length</i> 0100 = 1 m 0200 = 2 m 0300 = 3 m 0400 = 4 m 0500 = 5 m	b <i>Sensor type</i> SW3 = 3 switch outputs	c <i>Type of connection</i> 4 = M12 connector, 12-pin													

Accessories relays output	Order no.
Teach adapter (for sensor type RL1) M12 connector, 5-pin adapter with button	D8.C100.RL1.TEACH
Accessories switch output	Order no.
Visualization adapter (for sensor type SW3) M12 connector, 12-pin	D8.C100.SW3.VISUAL
Cables and connectors	Order no.
Preassembled cables M12 female connector with coupling nut, 5-pin, A coded, straight single ended 2 m [6.56'] PVC cable	05.00.6081.2211.002M
M12 female connector with coupling nut, 12-pin, A coded, straight single ended 2 m [6.56'] PVC cable	05.00.60B1.B211.002M
Connectors	M12 female connector with coupling nut, 5-pin, A coded, straight (metal/plastic) 05.B-8151-0/9 M12 female connector with coupling nut, 5-pin, A coded, right-angle (plastic) 05.B-8251-0/9 M12 female connector with coupling nut, 12-pin, A coded, straight (metal) 8.0000.5162.0000

Further Kübler cables and connectors can be found at: kuebler.com/connection-technology

Linear measuring technology

Draw-wire encoder C100	Base-Line	Measuring length max. 5 m
-------------------------------	------------------	----------------------------------

Technical data

Mechanical characteristics (draw-wire mechanics)		
Measuring range		1.0 ... 5.0 m
Measuring wire	material	AISI304 steel wire Nylon coated
	diameter	ø 0.9 mm ø 0.61 mm (ABZ Incremental)
Wire fastening	eyelet	
	internal diameter	ø 8 mm
	outer diameter	ø 15 mm
	height	2 mm
Speed max.		1 m/s
Acceleration max.		10 m/s ²
Linearity (whole measuring range)		
	analog	±0.8 %
	incremental (≤ 2 m)	±0.1 %
	incremental (> 2 m)	±0.3 %
	CANopen / relay	±0.5 %
Repetition accuracy (whole measuring range)		
	analog	±0.3 %
	incremental (≤ 2 m)	±0.1 %
	incremental (> 2 m)	±0.3 %
	CANopen / relay	±0.3 %
Pull-back force		typ. 2 N ¹⁾
Pull-out force		typ. 8 N
Drum circumference		245 mm
Type of connection		M12 connector, 5-pin cable, 2 m [6.56'] (only incremental)
Housing		polycarbonate reinforced with glass fibers
Protection		IP67
Temperature range		-40 °C ... +85 °C [-40 °F ... +185 °F]
Weight		approx. 0.5 kg [17.67 oz]
Shock resistance acc. to EN 60068-2-27		300 m/s ² , 11 ms
Vibration resistance acc. to EN 60068-2-6		100 m/s ² , 10 ... 500 Hz

Electrical characteristics		
Supply voltage		
Sensor type:		
A11, A22, R11, R22, R1C, R2C		12 ... 30 V DC
A44, R44, R4C		9 ... 30 V DC
RC1, RCT		9 ... 30 V DC
RL1, SW3		9 ... 30 V DC
I11, I12, I21, I22		9 ... 30 V DC

Analog sensor	
Output signal	analog
Resolution	12 bit

Incremental output	
Output signal	AB (Z optional)
Resolution	512 / 1024 ppr
Current consumption (non load)	max. 100 mA
Output current	max. 50 mA
Circuit	TTL

CANopen	
Output signal	CANopen (DS301)
Resolution	14 bit
Resolution inclinometer	0.1°
Accuracy inclinometer	±0.6°
Temperature drift inclinometer	±0.01 % / °C

Relay output	
Output signal	1x relay (Normally Open)
Maximum current	50 mA
Hysteresis	20 mm (factory setting)

Switch output	
Output signal	switch
Maximum current	0.5 A
Mechanical service life	
without load	min. 1,000,000 switching operations (60 switching operations/ min.)
under load	min. 30,000 switching operations (30 switching operations/ min.)

Approvals	
Electromagnetic compatibility	acc. to EN 61326-1, EN 61326-3-1
CE compliant in accordance with	
EMC Directive	2014/30/EU
RoHS Directive	2011/65/EU

1) May be lower at low temperatures.

Linear measuring technology

Draw-wire encoder C100 Base-Line Measuring length max. 5 m

Terminal assignment

Sensor type	Interface	Type of connection	M12 connector, 5-pin					
Analog sensor A11, R11, R1C	(2x) 4 ... 20 mA	1	Signal:	+V	0 V	I _{out 1}	I _{out 2} ¹⁾	n.c.
			Pin:	1	2	3	4	5

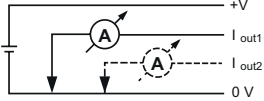

Sensor type	Interface	Type of connection	M12 connector, 5-pin					
Analog sensor A22, R22, R2C A44, R44, R4C	(2x) 0 ... 10 V (2x) 0.5 ... 4.5 V	1	Signal:	+V	0 V	U _{out 1}	U _{out 2} ¹⁾	n.c.
			Pin:	1	2	3	4	5

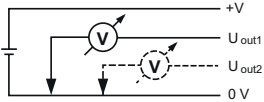

Sensor type	Interface	Type of connection	M12 connector, 5-pin					
I11, I12, I21, I22	incremental output	1	Signal:	+V	0 V	A	B	0
			Pin:	1	2	3	4	5

Sensor type	Interface	Type of connection	M12 connector, 5-pin					
RC1, RCT	CANopen	1	Signal:	+V	0 V	CAN-GND	CAN-H	CAN-L
			Pin:	2	3	1	4	5

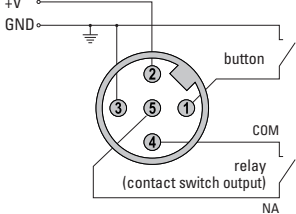
Sensor type	Interface	Type of connection	M12 connector, 5-pin					
RL1	relay	1	Signal:	+V	0 V	Teach	CAN-H	NO
			Pin:	2	3	1	4	5
			<p>The switching point of the relay can be set by means of a button connected to pin 1 (Teach). To do so, position the draw-wire mechanic at the desired switching point and then press the button once.</p> 					

Sensor type	Interface	Type of connection	Cable (isolate unused cores individually before initial start-up)					
I11, I12, I21, I22	incremental output	3	Signal:	+V	0 V	A	B	0
			Core color:	WH	YE	BN	GN	GY

Sensor type	Interface	Type of connection	M12 connector, 12-pin												
SW3	switching output	4	Signal:	NC 1	NO 1	C 1	NC 2	NO 2	C 2	NC 3	NO 3	C 3	n.c.	n.c.	n.c.
			Pin:	1	2	3	4	5	6	7	8	9	10	11	12

- | | | | | | |
|----------------------|------------------------------|---------|----------------------|--------|-------------------------|
| +V : | Supply voltage +V DC | Teach : | Teach function input | C 1 : | Switching contact C.1 |
| 0 V : | Supply voltage GND (0V) | C : | Relay contact C | C 2 : | Switching contact C.2 |
| I _{out 1} : | Current output 1 | NO : | Relay contact N.O. | C 3 : | Switching contact C.3 |
| I _{out 2} : | Current output 2 | n.c. : | not connected | NO 1 : | Switching contact N.O.1 |
| U _{out 1} : | Voltage output 1 | AGND : | Analog Ground | NO 2 : | Switching contact N.O.2 |
| U _{out 2} : | Voltage output 2 | | | NO 3 : | Switching contact N.O.3 |
| A : | Incremental output channel A | | | NC 1 : | Switching contact N.C.1 |
| B : | Incremental output channel B | | | NC 2 : | Switching contact N.C.2 |
| 0 : | Reference signal | | | NC 3 : | Switching contact N.C.3 |

Top view of mating side, male contact base

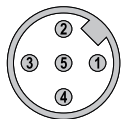

M12 connector, 5-pin

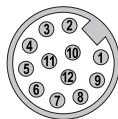

M12 connector, 12-pin

1) Only in case of redundant ordering option sensor type R11, R1C, R22, R2C, R44, R4C (otherwise n.c.).

Linear measuring technology

Draw-wire encoder C100	Base-Line	Measuring length max. 5 m
-------------------------------	------------------	----------------------------------

Technology in detail

Operating principle

Construction

The core of a draw-wire device is a drum mounted on bearings, onto which a wire is wound. Winding takes place via a spring-loaded device.

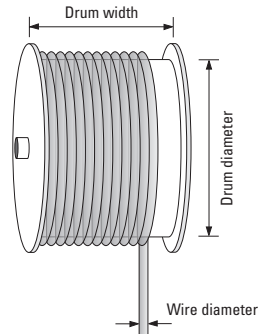

Note

Exceeding the maximum extension length of the draw-wire will lead to damage to the wire and the mechanics.

Inclinometer with option RC1

Setting possibility 360°



Setting possibility ±180°



Redundant signals possible.

Setting possibilities:

- Switching between setting possibilities 180° and 360°.
- Switching between synchronous and asynchronous output.
- Change of direction of rotation (cw/ccw).
- Setting and resetting an offset.

Linear measuring technology

Draw-wire encoder C100

Base-Line

Measuring length max. 5 m

Dimensions

Dimensions in mm [inch]

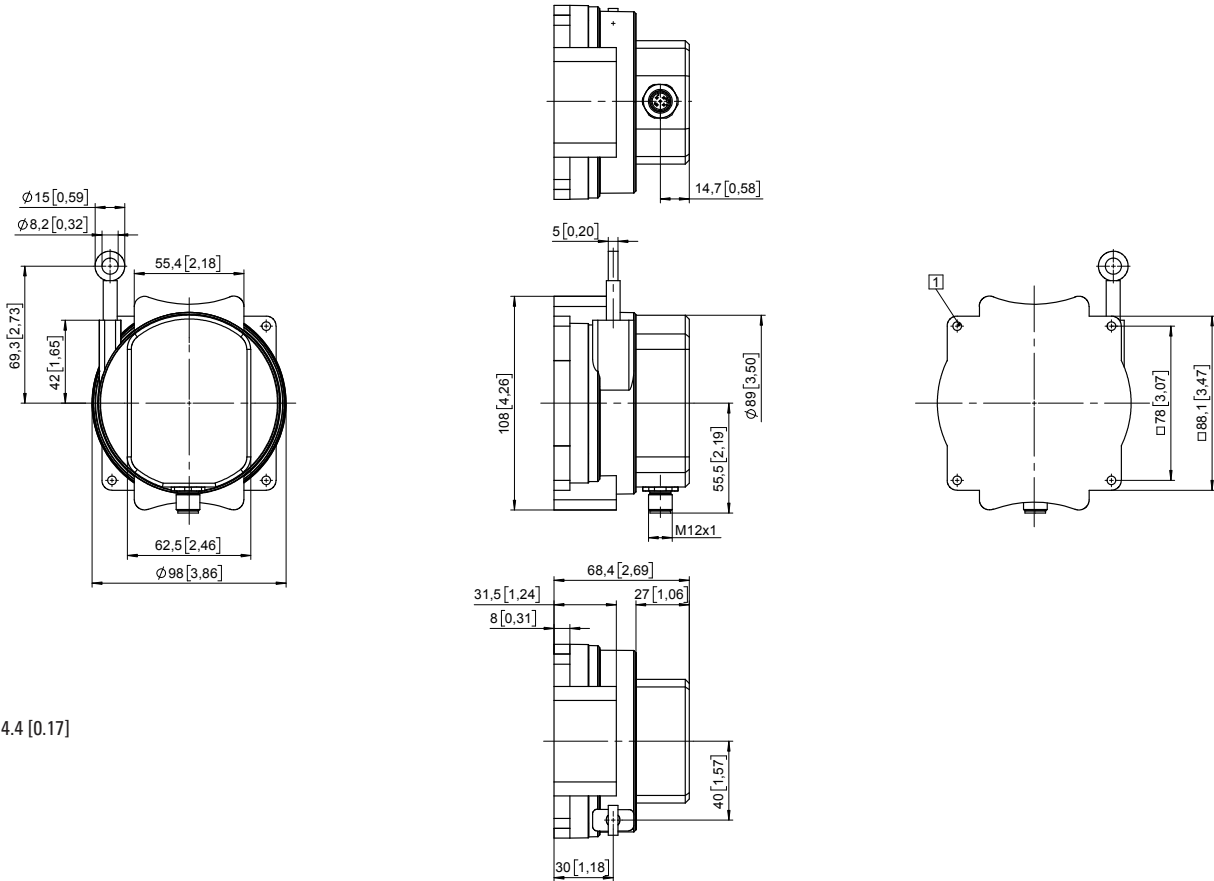

1 4 x $\varnothing 4.4$ [0.17]