

Linear measuring technology

Draw-wire encoder C120 Performance-Line Measuring length max. 6 m

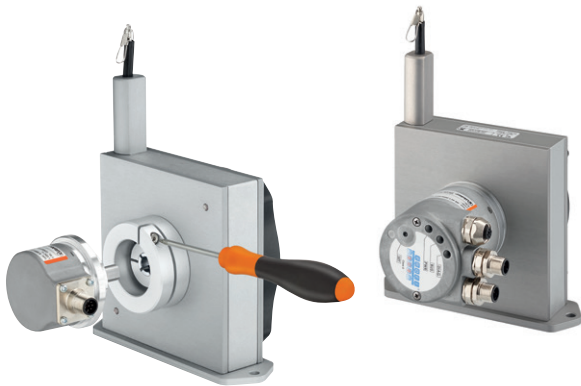

These draw-wire mechanics C120 can be used up to a measuring length of 6 meters.

This draw-wire mechanics may be combined with the proven Kübler Sendix encoders with incremental or absolute interface, as well as with analog sensors.

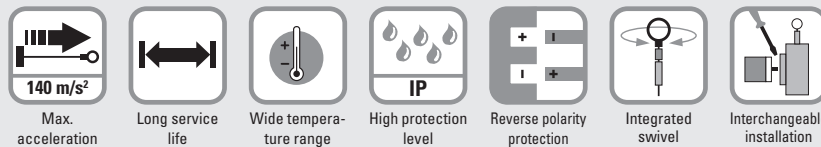

Robust

- The titanium-anodized aluminum housing and the stainless steel wires allow for using the mechanics even in harsh conditions.
- Wear-free wire exit thanks to special plain bearing guide.
- Various wire types and wire fastenings.

Versatile

- High traverse speed, up to max. 10 m/s.
- High acceleration, up to max. 140 m/s².
- Quick fastening by means of 2 screws.
- Various connection possibilities available.
- Interchangeable encoders (interchangeable installation).

Order code with encoder (incremental, absolute)

D8.XC1.XXXX.XXXX.XXXX

- a** *Mechanics*
2 = interchangeable installation ¹⁾
4 = fixed installation ²⁾
 - b** *Measuring range*
0400 = 4000 mm
0500 = 5000 mm
0600 = 6000 mm
 - c** *Encoder used*
00 = Sendix 5000, incremental
M3 = Sendix M5863, absolute
F3 = Sendix F5863, absolute
63 = Sendix 5863, absolute
M8 = Sendix M5868, absolute
F8 = Sendix F5868 absolute
68 = Sendix 5868, absolute
 - d** *Output circuit*
depends on the encoder used
 - e** *Type of connection*
depends on the encoder used
 - f** *Resolution / Protocol / Options*
depends on the encoder used
- Optional on request*
- Other measuring ranges
 - Cable diameter 1 mm
 - Other wire fastening (wire clip = standard): eyelet, M4 thread or carabiner ring
 - Modified cable and/or connector orientation
 - Modified cable outlet direction
 - Sensor protection level IP67
 - Improved linearity 0.02 %

Standard resolutions for draw-wire with incremental encoder Sendix 5000			
Drum circumference [mm]	317.68	317.68	317.68
Pulses / revolution [ppr]	1000	2000	4000
Pulses / mm	3.1	6.3	12.6
Resolution [mm]	0.32	0.16	0.08

Standard resolutions for draw-wire with absolute encoder Sendix M5863 (12 bit ST) or M5868 (12 bit ST, programmable via bus)	
Drum circumference [mm]	317.68
Pulses / revolution [ppr]	4096
Pulses / mm	12.9
Resolution [mm]	0.08

1) Draw-wire mechanics with standard flange. The encoder can be replaced by the customer.
2) The encoder can only be replaced at the factory.

Linear measuring technology

Draw-wire encoder C120

Performance-Line

Measuring length max. 6 m

Recommended standard variants (with incremental, absolute encoder)

Order no. draw-wire encoder	Mounted encoder	Interface	Power supply	Type of connection	Resolution / Protocol	Option
D8.xC1.xxxx.0054.2000	Sendix 5000 (8.5000.8354.2000)	Push-pull with inverted signal	10 ... 30 V DC	1 x radial M12 connector	2000 ppr	-
D8.xC1.xxxx.M324.G222	Sendix M5863 (8.M5863.3524.G222)	SSI	10 ... 30 V DC	1 x radial M12 connector	4096 ppr / SSI-Gray-Code	-
D8.xC1.xxxx.M824.2122	Sendix M5868 (8.M5868.3524.2122)	CANopen	10 ... 30 V DC	1 x radial M12 connector	CANopen encoderprofil DS406 V4.0	-

Other variants (with absolute encoder)

Order no. draw-wire encoder	Mounted encoder	Interface	Power supply	Type of connection	Resolution / Protocol	Option
D8.xC1.xxxx.F326.G223	Sendix F5863 (8.F5863.1226.G223)	SSI	10 ... 30 V DC	1 x radial M12 connector	4096 ppr / SSI-Gray-Code	SET button + status LED
D8.xC1.xxxx.6326.G223	Sendix 5863 (8.5863.1226.G223)	SSI	10 ... 30 V DC	1 x radial M12 connector	4096 ppr / SSI-Gray-Code	SET button + status LED
D8.xC1.xxxx.F82E.2123	Sendix F5868 (8.F5868.122E.2123)	CANopen	10 ... 30 V DC	1 x radial M12 connector	CANopen encoder profile DS406 V3.2	SET button
D8.xC1.xxxx.6822.2123	Sendix 5868 (8.5868.1222.2123)	CANopen	10 ... 30 V DC	2 x radial M12 connector	CANopen encoder profile DS406 V3.2	SET button
D8.xC1.xxxx.M834.3222	Sendix M5868 (8.M5868.3534.3222)	SAE J1939	10 ... 30 V DC	1 x radial M12 connector	SAE J1939	-
D8.xC1.xxxx.M844.4122	Sendix M5868 (8.M5868.3544.4122)	IO-Link	18 ... 30 V DC	1 x radial M12 connector	IO-Link	-
D8.xC1.xxxx.6832.3113	Sendix 5868 (8.5868.1232.3113)	PROFIBUS	10 ... 30 V DC	3 x radial M12 connector	Profibus-DP V0 encoder profile Class 2	SET button
D8.xC1.xxxx.68B2.B212	Sendix 5868 (8.5868.12B2.B212)	EtherCAT	10 ... 30 V DC	3 x radial M12 connector	EtherCAT with CoE 3.2.10	-
D8.xC1.xxxx.F8CN.C122	Sendix F5868 (8.F5868.12CN.C122)	PROFINET IO	10 ... 30 V DC	3 x axial M12 connector	PROFINET encoder profile version 4.2	-
D8.xC1.xxxx.F8AN.A222	Sendix F5868 (8.F5868.12AN.A222)	EtherNet/IP	10 ... 30 V DC	3 x axial M12 connector	EtherNet/IP	-

Order code with encoder (analog, scalable with limit switch function)

D8.XC1.XXXX.M1XX.XXXX

a *Mechanics*
2 = interchangeable installation ¹⁾
4 = fixed installation ²⁾

b *Measuring range*
0400 = 4000 mm
0500 = 5000 mm
0600 = 6000 mm

c *Encoder used*
M1 = Sendix M5861, absolute ³⁾

d *Output circuit*
depends on the encoder used

e *Type of connection*
depends on the encoder used

f *Resolution / Protocol / Options*
depends on the encoder used

Optional on request

- Other measuring ranges
- Cable diameter 1 mm
- Other wire fastening (wire clip = standard):
M4 thread, eyelet or carabiner ring
- Modified cable and/or connector orientation
- Modified cable outlet direction
- Sensor protection level IP67

Recommended standard variants (with encoder analog, scalable with limit switch function)

Order no. draw-wire encoder	Mounted encoder	Interface	Power supply	Type of connection	Resolution / Protocol	Option
D8.xC1.xxxx.M134.3612	Sendix M5861 (8.M5861.3534.3612)	Analog, 4 ... 20 mA	10 ... 30 V DC	radial M12 connector	12 Bit / 4 ... 20 mA	scalable without limit switch function ⁴⁾
D8.xC1.xxxx.M144.4612	Sendix M5861 (8.M5861.3544.4612)	Analog, 0 ... 10 V	15 ... 30 V DC	radial M12 connector	12 Bit / 0 ... 10 V	scalable without limit switch function ⁴⁾
D8.xC1.xxxx.M134.3512	Sendix M5861 (8.M5861.3534.3512)	Analog, 4 ... 20 mA	10 ... 30 V DC	radial M12 connector	12 Bit / 4 ... 20 mA	scalable with limit switch function ⁵⁾
D8.xC1.xxxx.M144.4512	Sendix M5861 (8.M5861.3544.4512)	Analog, 0 ... 10 V	15 ... 30 V DC	radial M12 connector	12 Bit / 0 ... 10 V	scalable with limit switch function ⁵⁾

1) Draw-wire mechanics with standard flange. The encoder can be replaced by the customer.

2) The encoder can only be replaced at the factory.

3) With ccw option.

4) Delivery condition: scaled to measuring range.
Description for scaling and limit switch function see data sheet M5861.

5) Delivery condition: unscaled.
Description for scaling and limit switch function see data sheet M5861.

Linear measuring technology

Draw-wire encoder C120	Performance-Line	Measuring length max. 6 m
-------------------------------	-------------------------	----------------------------------

Technical data

Mechanical characteristics (draw-wire mechanics)	
Measuring range	6000 mm
Extension force	F _{min} 8.8 N F _{max} 12.3 N
Speed max.	10 m/s
Acceleration max.	140 m/s ²
Linearity (of the measuring range)	
with analog sensor	±0.10 %
with encoder	±0.05 % ±0.02 % ¹⁾
Weight	approx. 1600 g [56.44 oz] (depending on the sensor/encoder used)
Material	housing titanium-anodized aluminum wire stainless steel ø 0.5 mm ø 1 mm can be supplied as a special up to measuring range 3000 mm (other wire types on request)
Protection acc. to EN 60529	IP65 (sensor)

Electrical characteristics (digital output)
The electrical characteristics of the draw-wire mechanics with digital output can be found in the data sheets of the encoders

Approvals
CE compliant in accordance with
EMC Directive 2014/30/EU
RoHS Directive 2011/65/EU

Electrical characteristics (analog sensor, scaled to measuring range)			
Version	A22	A11	A33
Analog output	0 ... 10 V	4 ... 20 mA	potentiometer
Output	0 ... 10 V / galv. isolated, 4 conductors	4 ... 20 mA / 2 conductors	1 kΩ
Supply voltage	12 ... 30 V DC	12 ... 30 V DC	max. 30 V DC
Recommended slider current	–	–	< 1 μA
Max. current consumption	22.5 mA (no load)	50 mA	–
Reverse polarity protection	yes	yes	–
Working temperature	-20 °C ... +85 °C [-4 °F ... +185 °F] -40 °C ... +85 °C [-40 °F ... +185 °F] ²⁾	-20 °C ... +85 °C [-4 °F ... +185 °F] -40 °C ... +85 °C [-40 °F ... +185 °F] ²⁾	-20 °C ... +85 °C [-4 °F ... +185 °F] -40 °C ... +85 °C [-40 °F ... +185 °F] ²⁾ -20 °C ... +120 °C [-4 °F ... +248 °F] ²⁾

1) On request for encoder version (see order code **Ⓢ**):
00 in combination with interchangeable installation (order code **ⓐ** = 2) or fixed installation (order code **ⓐ** = 4)
F3, F3, F8, F8 in combination with interchangeable installation (order code **ⓐ** = 2)
 2) Optional on request.

Linear measuring technology

Draw-wire encoder C120	Performance-Line	Measuring length max. 6 m
-------------------------------	-------------------------	----------------------------------

Terminal assignment (analog sensor)

Analog sensor A11 (4 ... 20 mA)			R/I converter					
			Signal:	+V	n.c.	I _{out}		n.c.
			Cable ¹⁾	Core color:	BN	WH		BU
	M12 connector, 4-pin	Pin:	1	2	3	4		

Analog sensor A22 (0 ... 10 V DC)			R/U converter					
			Signal:	+V	U _{out}	0 V		0 V _{out}
			Cable ¹⁾	Core color:	BN	WH		BU
	M12 connector, 4-pin	Pin:	1	2	3	4		

Analog sensor A33 (Potentiometer 1 kΩ)			Potentiometer					
			Signal:	+V	Out	0 V		n.c.
			Cable ¹⁾	Core color:	BN	WH		BU
	M12 connector, 4-pin	Pin:	1	2	3	4		

Top view of mating side, male contact base

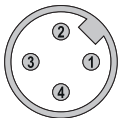

M12 connector, 4-pin

1) Isolate unused cores individually before initial start-up.

Linear measuring technology

Draw-wire encoder C120

Performance-Line

Measuring length max. 6 m

Technology in detail

Operating principle

Construction

The core of a draw-wire device is a drum mounted on bearings, onto which a wire is wound. Winding takes place via a spring-loaded device.

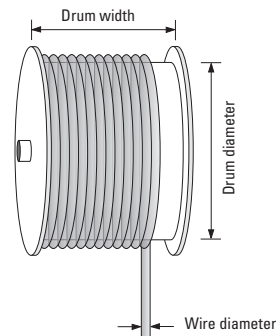

Note

Exceeding the maximum extension length of the draw-wire will lead to damage to the wire and the mechanics.

Wire fastenings

Clip
D8.xx1.xxxx.xxxx



M4 thread
D8.xxA.xxxx.xxxx



Eyelet
D8.xxJ.xxxx.xxxx



Carabiner ring
D8.xxM.xxxx.xxxx



ball-bearing swivel
(no torsion of the measuring wire during installation)

rubber stopper

measuring wire

Wire types

- V2A, \varnothing 0.5 mm (standard)

Optional on request:

- V4A, \varnothing 0.51 mm

- Coramid, \varnothing 0.6 mm

- V4A plastic coated, 1.0 mm (V4A = \varnothing 0.81 mm)



Extension wire

For optimum use of the measuring range by extending the wire length, e. g. to allow realizing a pre-extension in the application. Especially combined with analog interfaces.



Linear measuring technology

Draw-wire encoder C120	Performance-Line	Measuring length max. 6 m
-------------------------------	-------------------------	----------------------------------

Technology in detail

Application-specific installation possibilities

guide pulley

guide pulley

Interchangeable installation

Easy adjustment of the connector or cable orientation. Exchange of individual components possible.

Requirements for encoders:

- clamping flange \varnothing 58 mm
- shaft 10 x 20 mm

Individual wire outlet

wire outlet at the top 0°
D8.xx**1**.xxxx.xxxx.xxxx

wire outlet left 270°
D8.xx**D**.xxxx.xxxx.xxxx

wire outlet right 90°
D8.xx**C**.xxxx.xxxx.xxxx

wire outlet below 180°
D8.xx**E**.xxxx.xxxx.xxxx

Individual cable / connector orientation
on request

Linear measuring technology

Draw-wire encoder C120

Performance-Line

Measuring length max. 6 m

Dimensions

Dimensions in mm [inch]

Draw-wire mechanics with encoder Fixed installation

Dimension B depends on the encoder used	
Encoder	B
Sendix incremental (5000) D8.4C1.xxxx.00xx.xxxx	54.25 [2.14]
Sendix absolute (F5863) D8.4C1.xxxx.F3xx.xxxx	66.75 [2.63]
Sendix absolute (5863) D8.4C1.xxxx.63xx.xxxx	66.75 [2.63]
Sendix absolute (F5868, CANopen) D8.4C1.xxxx.F8xx.21xx	88.25 [3.47]
Sendix absolute (F5868, EtherNet/IP) D8.4C1.xxxx.F8xx.A2xx	76.75 [3.02]
Sendix absolute (5868) D8.4C1.xxxx.68xx.xxxx	67.35 [2.65]
Sendix absolute (M586x) D8.4C1.xxxx.Mxxx.xxxx	67.05 [2.64]

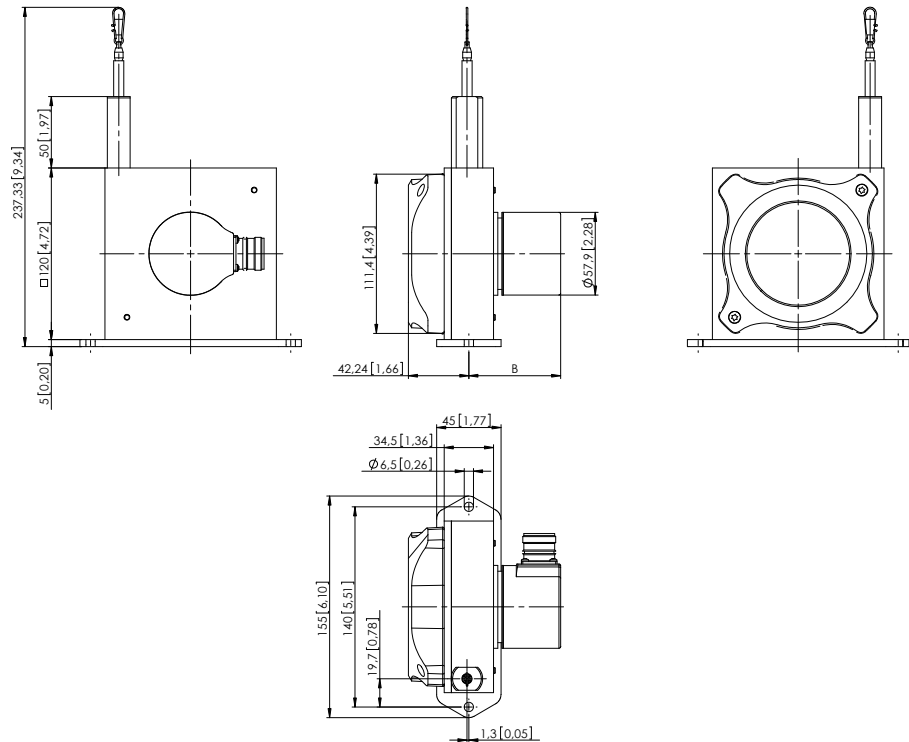

Draw-wire mechanics with encoder

Interchangeable installation, clamping flange

Dimension B depends on the encoder used	
Encoder	B
Sendix incremental (5000) D8.2C1.xxxx.00xx.xxxx	77.25 [3.04]
Sendix absolute (F5863) D8.2C1.xxxx.F3xx.xxxx	89.75 [3.53]
Sendix absolute (5863) D8.2C1.xxxx.63xx.xxxx	89.75 [3.53]
Sendix absolute (F5868, CANopen) D8.2C1.xxxx.F8xx.21xx	111.25 [4.38]
Sendix absolute (F5868, EtherNet/IP) D8.2C1.xxxx.F8xx.A2xx	99.75 [1.69]
Sendix absolute (5868) D8.2C1.xxxx.68xx.xxxx	90.35 [3.93]
Sendix absolute (M586x) D8.2C1.xxxx.Mxxx.xxxx	90.05 [3.54]

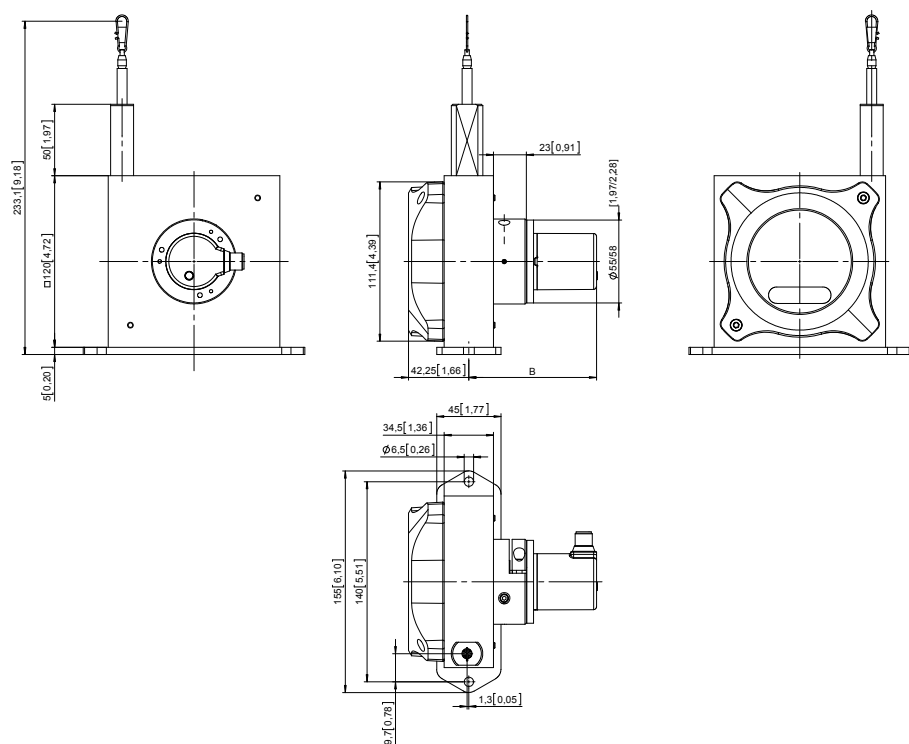

Draw-wire encoder C120 **Performance-Line** **Measuring length max. 6 m**

Dimensions

Dimensions in mm [inch]

Draw-wire mechanics with analog sensor
(scaled on measuring range)

