

Absolute encoders - singleturn

Compact optical	Sendix F3653 / F3673 (shaft / hollow shaft)	SSI / BiSS + incremental
------------------------	--	---------------------------------



The Sendix F36 singleturn with the patented Intelligent Scan Technology™ and SSI or BiSS interface boasts exceptional ruggedness and compact dimensions.

With a size of just 36 x 42 mm it offers a through hollow shaft of up to 8 mm or a blind hollow shaft of up to 10 mm. Its high-precision optical sensor technology can achieve a resolution of up to 17 bits.



Safety-Lock™	Temperature range -40°...+90°C	High protection level IP	High shaft load capacity	Shock / vibration resistant	Magnetic field proof	Short-circuit proof	Reverse polarity protection	SinCos	Intelligent Scan Technology™	Surface protection salt spray-tested optional

Reliable and magnetically insensitive

- Sturdy bearing construction in Safety-Lock™ design for resistance against vibration and installation errors.
- Ideal for use outdoors thanks to IP67 protection and wide temperature range from -40 °C up to +90 °C.
- Patented Intelligent Scan Technology™ with all singleturn and multiturn functions on one single OptoASIC - offering highest reliability, a high resolution up to 17 bits and 100 % magnetic field insensitivity.

Optimized performance

- High-precision with a data refresh rate of the position value ≤ 1µs.
- High-resolution feedback in real-time via incremental outputs SinCos and RS422.
- Short control cycles, clock rate with SSI up to 2 MHz / with BiSS up to 10 MHz.

Order code	8.F3653	.XXXX	.XX	12	If for each parameter of an encoder the <u>underlined preferred option</u> is selected, then the delivery time will be 10 working days for a maximum of 10 pieces. Qts. up to 50 pcs. of these types generally have a delivery time of 15 working days.	
Shaft version	Type	a	b	c		

- a Flange**
 1 = clamping flange, IP67, ø 36 mm [1.42"]
 3 = clamping flange, IP65, ø 36 mm [1.42"]
 2 = synchro flange, IP67, ø 36 mm [1.42"]
4 = synchro flange, IP65, ø 36 mm [1.42"]
- b Shaft (ø x L), with flat**
 1 = ø 6 x 12.5 mm [0.24 x 0.49"]
3 = ø 8 x 15 mm [0.32 x 0.59"]
 5 = ø 10 x 20 mm [0.39 x 0.79"]
 2 = ø 1/4" x 12.5 mm [0.49"]
 4 = ø 3/8" x 5/8"

- c Interface / supply voltage**
 1 = SSI, BiSS / 5 V DC
2 = SSI, BiSS / 10 ... 30 V DC
 3 = SSI, BiSS + 2048 ppr. SinCos / 5 V DC
 4 = SSI, BiSS + 2048 ppr. SinCos / 10 ... 30 V DC
 5 = SSI, BiSS / 5 V DC, with sensor output
 6 = SSI, BiSS + 2048 ppr. SinCos / 5 V DC, with sensor output
 7 = SSI, BiSS + 2048 ppr. RS422 / 5 V DC
 8 = SSI, BiSS + 2048 ppr. RS422 / 10 ... 30 V DC

- d Type of connection**
1 = tangential cable, 1 m [3.28] PUR
 3 = tangential cable, 5 m [16.40] PUR
 F = tangential cable, special length PUR *)
 8 = axial M12 connector, 8-pin ¹⁾

- e Code**
 B = SSI, binary
 C = BiSS, binary
G = SSI, gray
- f Resolution**
 A = 10 bit
 2 = 12 bit
3 = 13 bit
 4 = 14 bit
 7 = 17 bit

Optional on request
 - surface protection salt spray tested
 - other resolutions

*) Available special lengths (connection type F):
 2, 3, 8, 10, 15 m [6.56, 9.84, 26.25, 32.80, 49.21"]
 order code expansion .XXXX = length in dm
 ex.: 8.F3653.432F.G312.0030 (for cable length 3 m)

1) Only with output circuits 1 and 2.

Absolute encoders - singleturn

Compact optical	Sendix F3653 / F3673 (shaft / hollow shaft)	SSI / BiSS + incremental
------------------------	--	---------------------------------

Order code	8.F3673	.XXXXX	.XX12	<p>If for each parameter of an encoder the <u>underlined preferred option</u> is selected, then the delivery time will be 10 working days for a maximum of 10 pieces. Qts. up to 50 pcs. of these types generally have a delivery time of 15 working days.</p>							
Hollow shaft	Type	<table border="1" style="font-size: 8px; border-collapse: collapse;"> <tr> <td style="text-align: center;">a</td> <td style="text-align: center;">b</td> <td style="text-align: center;">c</td> <td style="text-align: center;">d</td> <td style="text-align: center;">e</td> <td style="text-align: center;">f</td> </tr> </table>	a	b	c	d	e	f			
a	b	c	d	e	f						
a Flange 1 = with spring element, short, IP65 3 = with spring element, long, IP65 <u>2 = with stator coupling, IP65, ø 46 mm [1.81"]</u>		c Interface / supply voltage 1 = SSI, BiSS / 5 V DC <u>2 = SSI, BiSS / 10 ... 30 V DC</u> 3 = SSI, BiSS + 2048 ppr. SinCos / 5 V DC 4 = SSI, BiSS + 2048 ppr. SinCos / 10 ... 30 V DC 5 = SSI, BiSS / 5 V DC, with sensor output 6 = SSI, BiSS + 2048 ppr. SinCos / 5 V DC, with sensor output 7 = SSI, BiSS + 2048 ppr. RS422 / 5 V DC 8 = SSI, BiSS + 2048 ppr. RS422 / 10 ... 30 V DC		e Code B = SSI, binary C = BiSS, binary <u>G = SSI, gray</u>							
b Through hollow shaft 1 = ø 6 mm [0.24"] 3 = ø 8 mm [0.32"] 2 = ø 1/4" <i>Blind hollow shaft</i> <i>(insertion depth max. 14.5 mm [0.57"])</i> <u>4 = ø 10 mm [0.39"]</u>		d Type of connection <u>1 = tangential cable, 1 m [3.28] PUR</u> 3 = tangential cable, 5 m [16.40] PUR F = tangential cable, special length PUR *) 8 = axial M12 connector, 8-pin ¹⁾		f Resolution A = 10 bit 2 = 12 bit <u>3 = 13 bit</u> 4 = 14 bit 7 = 17 bit							
		*) Available special lengths (connection type F): 2, 3, 8, 10, 15 m [6.56, 9.84, 26.25, 32.80, 49.21'] order code expansion .XXXX = length in dm ex.: 8.F3673.242F.G312.0030 (for cable length 3 m)		<i>Optional on request</i> - surface protection - salt spray tested - other resolutions							

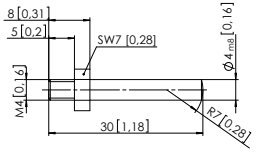
Mounting accessory for shaft encoders	Order no.
Coupling Bellows coupling ø 19 mm [0.75"] for shaft 8 mm [0.32"]	8.0000.1102.0808
Mounting accessory for hollow shaft encoders Dimensions in mm [inch]	Order no.
Torque pin, ø 4 mm for flange with spring element (flange type 3 + 6)	8.0010.4700.0000
with fixing thread 	
Cables and connectors	Order no.
Preassembled cables M12 female connector with coupling nut, 8-pin, A coded, straight open ended 2 m [6.56'] PUR cable	05.00.6051.8211.002M
Connectors M12 female connector with coupling nut, 8-pin, A coded, straight (metal)	05.CMB 8181-0

Further Kübler accessories can be found at: kuebler.com/accessories
 Further Kübler cables and connectors can be found at: kuebler.com/connection-technology

1) Only with interfaces 1 and 2 in combination with blind hollow shaft 10 mm [0.39"].

Absolute encoders - singleturn

Compact optical

Sendix F3653 / F3673 (shaft / hollow shaft)

SSI / BiSS + incremental

Technical data

Mechanical characteristics

Maximum speed	
shaft version without shaft seal (IP65) or blind hollow shaft version	12000 min ⁻¹ 10000 min ⁻¹ (continuous)
shaft version with shaft seal (IP67) or hollow shaft version	10000 min ⁻¹ 8000 min ⁻¹ (continuous)
Starting torque at 20 °C [68 °F]	
without shaft seal	< 0.007 Nm
with shaft seal (IP67)	< 0.01 Nm
Shaft load capacity	radial 40 N axial 20 N
Weight	approx. 0.2 kg [7.06 oz]
Protection	housing side IP67 acc. to EN 60529 shaft side IP65 (solid shaft version opt. IP67)
Working temperature range	-40 °C ... +90 °C [-40 °F ... +194 °F]
Materials	shaft / hollow shaft stainless steel flange aluminum housing zinc die-cast cable PUR
Shock resistance acc. to EN 60068-2-27	2500 m/s ² , 6 ms
Vibration resistance acc. to EN 60068-2-6	100 m/s ² , 55 ... 2000 Hz

Electrical characteristics

Supply voltage	5 V DC (±5 %) or 10 ... 30 V DC
Current consumption (no load)	5 V DC max. 60 mA 10 ... 30 V DC max. 30 mA
Reverse polarity protection of the supply voltage	yes (only with 10 ... 30 V DC)
Short-circuit proof outputs	yes ¹⁾

SSI interface

Output driver	RS485 transceiver type
Permissible load / channel	max. +/- 30 mA
Signal level	HIGH typ. 3.8 V LOW with I _{Load} = 20 mA typ. 1.3 V
Resolution	10 ... 17 bit
Code	binary or gray
SSI clock rate	50 kHz ... 2 MHz
Data refresh rate	ST resolution ≤ 14 bit ≤ 1 μs ST resolution ≥ 15 bit 4 μs
Monoflop time	≤ 15 μs

Note: If the clock cycle starts within the monoflop time a second data transfer begins with the same data. If the clock cycle starts after the monoflop time the cycle begins with the new values. The update rate is dependent on the clock speed, data length and monoflop time.

BiSS interface

Output driver	RS485 transceiver type
Permissible load / channel	max. +/- 30 mA
Signal level	HIGH typ. 3.8 V LOW with I _{Load} = 20 mA typ. 1.3 V
Resolution	10 ... 17 bit
Code	binary
BiSS clock rate	50 kHz ... 10 MHz
Max. update rate	< 10 μs, depends on the clock rate and the data length
Data refresh rate	ST resolution ≤ 14 bit ≤ 1 μs ST resolution 17 bit 2.4 μs
Note:	– bidirectional, factory programmable parameters are: resolution, code, direction, alarms and warnings – CRC data verification

Incremental outputs (A/B)

	SinCos	RS422 TTL compatible
Max. frequency -3dB	400 kHz	400 kHz
Signal level	1 V _{pp} (±20 %)	HIGH: min. 2.5 V LOW: max. 0.5 V
Short circuit proof	yes ¹⁾	yes ¹⁾
Pulse rate	2048 ppr	2048 ppr

Status output

Output driver	open collector, internal pull up resistor 22 kOhm
Permissible load	max. 20 mA
Signal level	HIGH +V LOW < 1 V
Active	LOW

The status output serves to display various alarm or error messages. In normal operation the status output is HIGH (open collector with int. pull-up 22 kOhm).

An active status output (LOW) displays: LED fault (failure or ageing) – over-temperature – undervoltage In the SSI mode, the fault indication can only be reset by switching off the supply voltage to the device.

1) Short circuit proof to 0 V or to output when supply voltage correctly applied.

Absolute encoders - singleturn

Compact optical	Sendix F3653 / F3673 (shaft / hollow shaft)	SSI / BiSS + incremental
------------------------	--	---------------------------------

SET input	
Input	active HIGH
Input type	comparator
Signal level (+V = supply voltage)	HIGH min. 60 % of +V, max: +V LOW max. 30 % of +V
Input current	< 0.5 mA
Min. pulse duration (SET)	10 ms
Input delay	1 ms
New position data readable after	1 ms
Internal processing time	200 ms

The encoder can be set to zero at any position by means of a HIGH signal on the SET input. Other preset values can be factory-programmed. The SET input has a signal processing time of approx. 1 ms, after which the new position data can be read via SSI or BiSS. Once the SET function has been triggered, the encoder requires an internal processing time of typ. 200 ms; during this time the supply voltage must not be switched off.

The SET function should be carried out whilst the encoder is at rest.

If this input is not used, it should be connected to 0 V (Encoder ground GND) in order to avoid interferences.

DIR input	
Direction input: A HIGH signal switches the direction of rotation from the default cw to ccw. This inverted function can also be factory-programmed. If DIR is changed when the device is already switched on, then this will be interpreted as an error. The status output will switch to LOW.	
If this input is not used, it should be connected to 0 V (Encoder ground GND) in order to avoid interferences.	
Response time (DIR input)	1 ms

Power-ON
After Power-ON the device requires a time of approx. 150 ms before valid data can be read.
Hot plugging of the encoder should be avoided.

Approvals	
UL compliant in accordance with	File no. E224618
CE compliant in accordance with	
EMC Directive	2014/30/EU
RoHS Directive	2011/65/EU

Absolute encoders - singleturn

Compact optical	Sendix F3653 / F3673 (shaft / hollow shaft)	SSI / BiSS + incremental
------------------------	--	---------------------------------

Terminal assignment

Interface	Type of connection	Features	Cable (isolate unused cores individually before initial start-up)													
1, 2	1, 3, F	SET, DIR, Status	Signal:	0 V	+V	C+	C-	D+	D-	SET	DIR	Stat	⊥			
			Core color:	WH	BN	GN	YE	GY	PK	BU	RD	VT	shield			
1, 2	8	SET, DIR	M12 connector, 8-pin													
			Signal:	0 V	+V	C+	C-	D+	D-	SET	DIR	⊥				
			Pin:	1	2	3	4	5	6	7	8	PH				
3, 4	1, 3, F	SET, DIR, 2048 SinCos	Cable (isolate unused cores individually before initial start-up)													
			Signal:	0 V	+V	C+	C-	D+	D-	SET	DIR	A	\bar{A}	B	\bar{B}	⊥
			Core color:	WH	BN	GN	YE	GY	PK	BU	RD	BK	VT	GY-PK	RD-BU	shield
5	1, 3, F	SET, DIR, Sensor output	Cable (isolate unused cores individually before initial start-up)													
			Signal:	0 V	+V	C+	C-	D+	D-	SET	DIR	0 V _{sens}	+V _{sens}	⊥		
			Core color:	WH	BN	GN	YE	GY	PK	BU	RD	VT	RD-BU	shield		
6	1, 3, F	2048 SinCos, Sensor output	Cable (isolate unused cores individually before initial start-up)													
			Signal:	0 V	+V	C+	C-	D+	D-	0 V _{sens}	+V _{sens}	A	\bar{A}	B	\bar{B}	⊥
			Core color:	WH	BN	GN	YE	GY	PK	BU	RD	BK	VT	GY-PK	RD-BU	shield
7, 8	1, 3, F	2048 incr. RS422	Cable (isolate unused cores individually before initial start-up)													
			Signal:	0 V	+V	C+	C-	D+	D-	A	\bar{A}	B	\bar{B}	⊥		
			Core color:	WH	BN	GN	YE	GY	PK	BK	VT	GY-PK	RD-BU	shield		

- +V: Supply voltage encoder +V DC
- 0 V: Supply voltage encoder ground GND (0 V)
- 0 V_{sens} / +V_{sens}: Using the sensor outputs of the encoder, the voltage present can be measured and if necessary increased accordingly.
- C+, C-: Clock signal
- D+, D-: Data signal
- A, \bar{A} : Incremental output channel A (cosine)
- B, \bar{B} : Incremental output channel B (sine)
- SET: Set input
- DIR: Direction input
- PH ⊥: Plug connector housing (shield)

Top view of mating side, male contact base

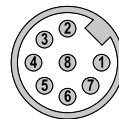

M12 connector, 8-pin

Absolute encoders - singleturn

Compact optical	Sendix F3653 / F3673 (shaft / hollow shaft)	SSI / BiSS + incremental
------------------------	--	---------------------------------

Dimensions shaft version

Dimensions in mm [inch]

Clamping flange, \varnothing 36 [1.42]

Flange type 1 and 3

1 3 x M3, 6 [0.24] deep

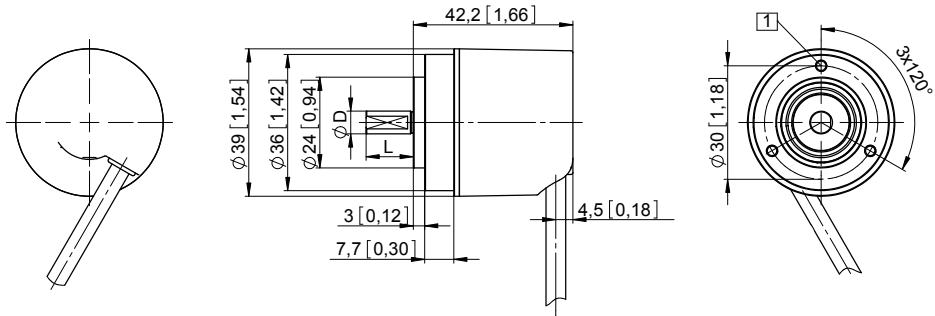

D	Fit	L
6 [0.24]	h7	12.5 [0.49]
8 [0.32]	h7	15 [0.59]
10 [0.39]	f7	20 [0.79]
1/4"	h7	12.5 [0.49]
3/8"	h7	5/8"

Synchro flange, \varnothing 36 [1.42]

Flange type 2 and 4

(drawing with cable)

1 4 x M3, 6 [0.24] deep

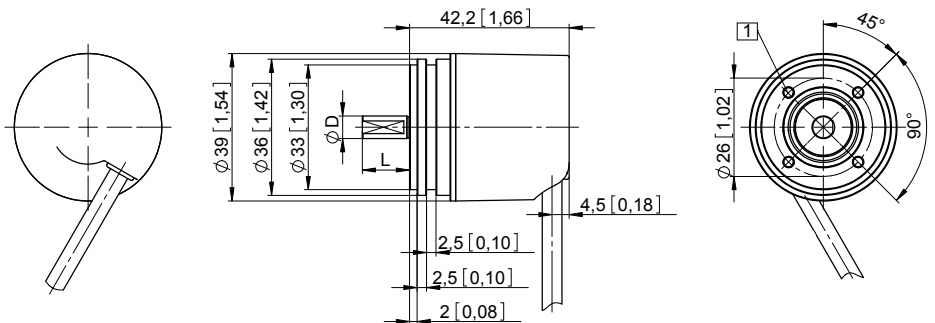

D	Fit	L
6 [0.24]	h7	12.5 [0.49]
8 [0.32]	h7	15 [0.59]
10 [0.39]	f7	20 [0.79]
1/4"	h7	12.5 [0.49]
3/8"	h7	5/8"

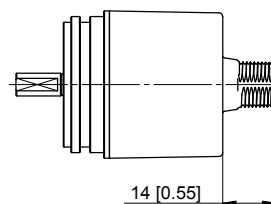

Drawing with M12 connector and type of connection 8

Absolute encoders - singleturn

Compact optical	Sendix F3653 / F3673 (shaft / hollow shaft)	SSI / BiSS + incremental
------------------------	--	---------------------------------

Dimensions hollow shaft version

Dimensions in mm [inch]

Flange with spring element

Flange type 1 and 3

(drawing with spring element short, spring element long is shown dashed)

- 1 4 x M2.5, 5 [0.2] deep
- 2 Spring element, short recommendation: torque pin DIN 7, ϕ 4 [0.16]
- 3 Spring element, long recommendation: torque pin DIN 7, ϕ 4 [0.16]
- 4 Recommended torque for the clamping ring 0.7 Nm

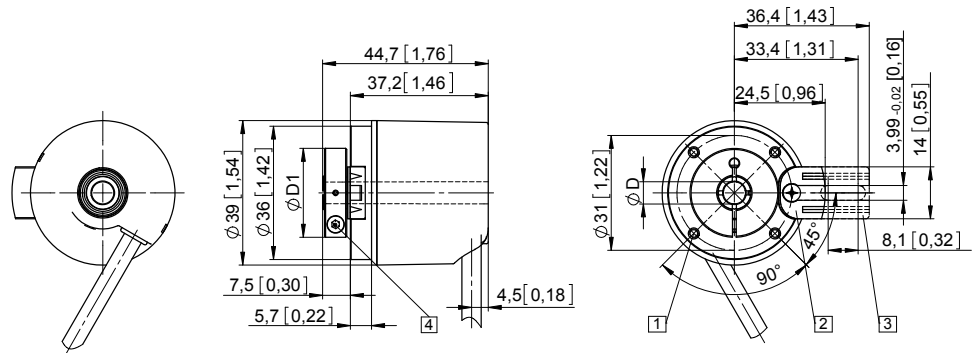

D	Fit	D1
6 [0.24]	H7	24 [0.94]
8 [0.32]	H7	25.5 [1.00]
10 [0.39] *)	H7	25.5 [1.00]
1/4"	H7	24 [0.94]

*) Blind hollow shaft, insertion depth max. = 14.5 mm [0.57"]

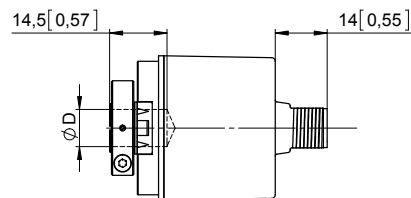

Blind hollow shaft for $D = \phi 10$
drawing with M12 connector and type of connection 8

Flange with stator coupling, $\phi 46$ [1.81"]

Flange type 2

- 1 Recommended torque for the clamping ring 0.7 Nm

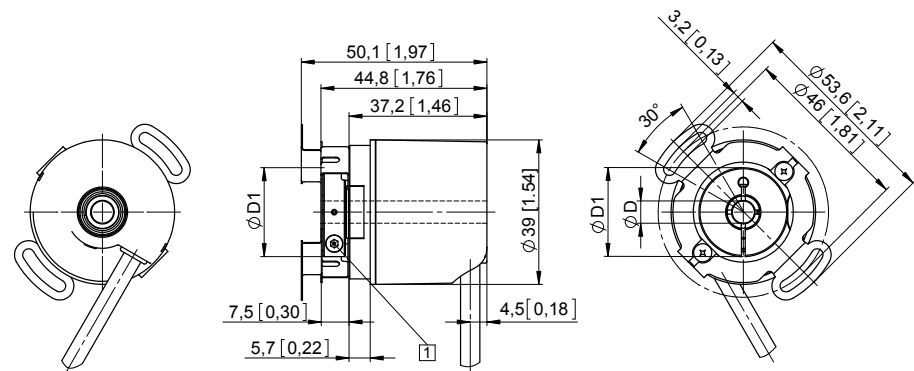

D	Fit	D1
6 [0.24]	H7	24 [0.94]
8 [0.32]	H7	25.5 [1.00]
10 [0.39] *)	H7	25.5 [1.00]
1/4"	H7	24 [0.94]

*) Blind hollow shaft, insertion depth max. = 14.5 mm [0.57"]

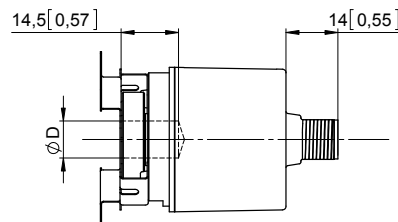

Blind hollow shaft for $D = \phi 10$
drawing with M12 connector and type of connection 8