

Absolute encoders – multiturn

Compact electronic multiturn, optical	Sendix F3663 / F3683 (shaft / hollow shaft)	SSI / BiSS + incremental
--	--	---------------------------------



The Sendix F36 multiturn with the patented Intelligent Scan Technology™ is an optical multiturn encoder in miniature format, without gears and with 100% insensitivity to magnetic fields.

With a size of just 36 x 42 mm it offers a through hollow shaft of up to 8 mm or a blind hollow shaft of up to 10 mm.



Safety-Lock™	High rotational speed	Temperature range -40°... +90°C	High protection level IP	High shaft load capacity	Shock / vibration resistant	Magnetic field proof	Reverse polarity protection	SinCos	Intelligent Scan Technology™	Surface protection salt spray-tested optional

Reliable and insensitive

- Sturdy bearing construction in Safety-Lock™ design for resistance against vibration and installation errors.
- Reduced number of components ensures magnetic insensitivity.
- IP67 protection and wide temperature range -40 °C ... +90 °C.
- Patented Intelligent Scan Technology™ (with all singleturn and multiturn functions on one single OptoASIC) - offering highest reliability, a high resolution up to 41 bits and 100% magnetic field insensitivity.

Optimized performance

- High precision with data refresh rate of the position value ≤ 1µs.
- High resolution feedback in real-time via incremental outputs SinCos and RS422.
- Short control cycles, clock frequency with SSI up to 2 MHz / with BiSS up to 10 MHz.

Order code	8.F3663	.XXXX.XXX2	If for each parameter of an encoder the <u>underlined preferred option</u> is selected, then the delivery time will be 10 working days for a maximum of 10 pieces. Qts. up to 50 pcs. of these types generally have a delivery time of 15 working days.								
Shaft version	Type	<table border="1" style="font-size: x-small;"> <tr> <td style="text-align: center;">a</td> <td style="text-align: center;">b</td> <td style="text-align: center;">c</td> <td style="text-align: center;">d</td> <td style="text-align: center;">e</td> <td style="text-align: center;">f</td> <td style="text-align: center;">g</td> </tr> </table>	a	b	c	d	e	f	g		
a	b	c	d	e	f	g					
a Flange	1 = clamping flange, IP67, ø 36 mm [1.42"] 3 = clamping flange, IP65, ø 36 mm [1.42"] 2 = synchro flange, IP67, ø 36 mm [1.42"] <u>4 = synchro flange, IP65, ø 36 mm [1.42"]</u>	c Interface / supply voltage	1 = SSI, BiSS / 5 V DC <u>2 = SSI, BiSS / 10 ... 30 V DC</u> 3 = SSI, BiSS + 2048 ppr. SinCos / 5 V DC 4 = SSI, BiSS + 2048 ppr. SinCos / 10 ... 30 V DC 5 = SSI, BiSS / 5 V DC, with sensor output 6 = SSI, BiSS + 2048 ppr. SinCos / 5 V DC, with sensor output 7 = SSI, BiSS + 2048 ppr. RS422 / 5 V DC 8 = SSI, BiSS + 2048 ppr. RS422 / 10 ... 30 V DC	e Code	Optional on request B = SSI, binary - surface protection C = BiSS, binary - salt spray tested <u>G = SSI, gray</u> - other resolutions						
b Shaft (ø x L), with flat	1 = ø 6 x 12.5 mm [0.24 x 0.49"] <u>3 = ø 8 x 15 mm [0.32 x 0.59"]</u> 5 = ø 10 x 20 mm [0.39 x 0.79"] 2 = ø 1/4" x 12.5 mm [0.49"] 4 = ø 3/8" x 5/8"	d Type of connection	<u>1 = tangential cable, 1 m [3.28'] PUR</u> 3 = tangential cable, 5 m [16.40'] PUR U = tangential cable, 10 m [32.81'] PUR 5 = tangential cable, 1 m [3.28'] PUR with M12 connector for central fastening, 8-pin ¹⁾	f Resolution (singleturn)	B = 9 bit ST A = 10 bit ST 2 = 12 bit ST <u>3 = 13 bit ST</u> 4 = 14 bit ST 7 = 17 bit ST						
				g Resolution (multiturn)	<u>2 = 12 bit MT</u> 6 = 16 bit MT 4 = 24 bit MT						

1) Only with interface 1 and 2.

Absolute encoders – multiturn

Compact electronic multiturn, optical	Sendix F3663 / F3683 (shaft / hollow shaft)	SSI / BiSS + incremental
--	--	---------------------------------

Order code	8.F3683	.XXXX.XXX2	<p>If for each parameter of an encoder the <u>underlined preferred option</u> is selected, then the delivery time will be 10 working days for a maximum of 10 pieces. Qts. up to 50 pcs. of these types generally have a delivery time of 15 working days.</p> <div style="text-align: right; border: 1px solid black; border-radius: 50%; padding: 2px 5px; display: inline-block;">10 by 10</div>
Hollow shaft	Type	a b c d e f g	
<p>a Flange 1 = with spring element, short, IP65 3 = with spring element, long, IP65 <u>2 = with stator coupling, IP65, ø 46 mm [1.81"]</u></p> <p>b Through hollow shaft 1 = ø 6 mm [0.24"] 3 = ø 8 mm [0.32"] 2 = ø 1/4" Blind hollow shaft (insertion depth max. 14.5 mm [0.57"]) <u>4 = ø 10 mm [0.39"]</u></p>	<p>c Interface / supply voltage 1 = SSI, BiSS / 5 V DC <u>2 = SSI, BiSS / 10 ... 30 V DC</u> 3 = SSI, BiSS + 2048 ppr. SinCos / 5 V DC 4 = SSI, BiSS + 2048 ppr. SinCos / 10 ... 30 V DC 5 = SSI, BiSS / 5 V DC, with sensor output 6 = SSI, BiSS + 2048 ppr. SinCos / 5 V DC, with sensor output 7 = SSI, BiSS + 2048 ppr. RS422 / 5 V DC 8 = SSI, BiSS + 2048 ppr. RS422 / 10 ... 30 V DC</p> <p>d Type of connection <u>1 = tangential cable, 1 m [3.28'] PUR</u> 3 = tangential cable, 5 m [16.40'] PUR U = tangential cable, 10 m [32.81'] PUR 5 = tangential cable, 1 m [3.28'] PUR with M12 connector for central fastening, 8-pin ¹⁾</p>	<p>e Code B = SSI, binary C = BiSS, binary <u>G = SSI, gray</u></p> <p>f Resolution (singleturn) B = 9 bit ST A = 10 bit ST 2 = 12 bit ST <u>3 = 13 bit ST</u> 4 = 14 bit ST 7 = 17 bit ST</p> <p>g Resolution (multiturn) <u>2 = 12 bit MT</u> 6 = 16 bit MT 4 = 24 bit MT</p>	<p><i>Optional on request</i></p> <ul style="list-style-type: none"> - surface protection - salt spray tested - other resolutions

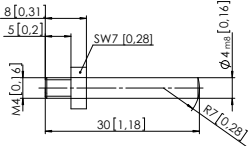
Mounting accessory for shaft encoders		Order no.
Coupling	Bellows coupling ø 19 mm [0.75"] for shaft 8 mm [0.32"]	8.0000.1102.0808
Mounting accessory for hollow shaft encoders <small>Dimensions in mm [inch]</small>		Order no.
Torque pin, ø 4 mm for flange with spring element (flange type 3 + 6)	with fixing thread 	8.0010.4700.0000
Cables and connectors		Order no.
Preassembled cables	M12 female connector with coupling nut, 8-pin, A coded, straight open ended 2 m [6.56'] PUR cable	05.00.6051.8211.002M
Connectors	M12 female connector with coupling nut, 8-pin, A coded, straight (metal)	05.CMB 8181-0

Further Kübler accessories can be found at: kuebler.com/accessories
 Further Kübler cables and connectors can be found at: kuebler.com/connection-technology

1) Only with output circuits 1 and 2.

Absolute encoders – multiturn

**Compact
electronic multiturn, optical**

Sendix F3663 / F3683 (shaft / hollow shaft)

SSI / BiSS + incremental

Technical data

Mechanical characteristics

Maximum speed	
shaft version without shaft seal (IP65) or blind hollow shaft version	12000 min ⁻¹ 10000 min ⁻¹ (continuous)
shaft version with shaft seal (IP67) or hollow shaft version	10000 min ⁻¹ 8000 min ⁻¹ (continuous)
Starting torque at 20 °C [68 °F]	
without shaft seal	< 0.007 Nm
with shaft seal (IP67)	< 0.01 Nm
Shaft load capacity	radial 40 N axial 20 N
Weight	approx. 0.2 kg [7.06 oz]
Protection	housing side IP67 acc. to EN 60529 shaft side IP65 (solid shaft version opt. IP67)
Working temperature range	-40 °C ... +90 °C [-40 °F ... +194 °F]
Materials	shaft / hollow shaft stainless steel flange aluminum housing zinc die-cast cable PUR
Shock resistance acc. to EN 60068-2-27	2500 m/s ² , 6 ms
Vibration resistance acc. to EN 60068-2-6	100 m/s ² , 55 ... 2000 Hz

Electrical characteristics

Supply voltage	5 V DC (±5 %) or 10 ... 30 V DC
Current consumption (no load)	5 V DC max. 60 mA 10 ... 30 V DC max. 30 mA
Reverse polarity protection of the supply voltage	yes (only with 10 ... 30 V DC)
Short-circuit proof outputs	yes ¹⁾

SSI interface

Output driver	RS485 transceiver type
Permissible load / channel	max. +/- 30 mA
Signal level	HIGH typ 3.8 V LOW with I _{Load} = 20 mA typ 1.3 V
Resolution singleturn	10 ... 17 bit
Number of revolutions (multiturn)	max. 24 bit
Code	binary or gray
SSI clock rate	50 kHz ... 2 MHz
Data refresh rate	ST resolution ≤ 14 bit ≤ 1 μs ST resolution ≥ 15 bit 4 μs
Monoflop time	≤ 15 μs

Note: If the clock cycle starts within the monoflop time a second data transfer begins with the same data. If the clock cycle starts after the monoflop time the cycle begins with the new values. The update rate is dependent on the clock speed, data length and monoflop time.

BiSS interface

Output driver	RS485 transceiver type
Permissible load / channel	max. +/- 30 mA
Signal level	HIGH typ 3.8 V LOW with I _{Load} = 20 mA typ 1.3 V
Resolution singleturn	10 ... 17 bit
Number of revolutions (multiturn)	max. 24 bit
Code	binary
BiSS Clock rate	50 kHz ... 10 MHz
Max. update rate	< 10 μs, depends on the clock rate and the data length
Data refresh rate	ST resolution ≤ 14 bit ≤ 1 μs ST resolution 17 bit 2.4 μs
Note:	- bidirectional, factory programmable parameters are: resolution, code, direction, alarms and warnings - CRC data verification

Incremental outputs (A/B)

	SinCos	RS422 TTL-compatible
Max. frequency -3dB	400 kHz	400 kHz
Signal level	1 V _{pp} (± 20%)	HIGH: min. 2.5 V LOW: max. 0.5 V
Short circuit proof	yes ¹⁾	yes ¹⁾
Pulse rate	2048 ppr	2048 ppr

Status output

Output driver	open collector, internal pull up resistor 22 kOhm
Permissible load	max. 20 mA
Signal level	HIGH +V LOW < 1 V
Active	LOW

The status output serves to display various alarm or error messages. In normal operation the status output is HIGH (open collector with int. pull-up 22 kOhm).

An active status output (LOW) displays:
LED fault (failure or ageing) – over-temperature – undervoltage
In the SSI mode, the fault indication can only be reset by switching off the supply voltage to the device.

1) Short circuit proof to 0 V or to output when supply voltage correctly applied.

Absolute encoders – multiturn

Compact electronic multiturn, optical	Sendix F3663 / F3683 (shaft / hollow shaft)	SSI / BiSS + incremental
--	--	---------------------------------

SET input	
Input	active HIGH
Input type	comparator
Signal level (+V = supply voltage)	HIGH min. 60 % of +V, max: +V LOW max. 30 % of +V
Input current	< 0.5 mA
Min. pulse duration (SET)	10 ms
Input delay	1 ms
New position data readable after	1 ms
Internal processing time	200 ms
<p>The encoder can be set to zero at any position by means of a HIGH signal on the SET input. Other preset values can be factory-programmed. The SET input has a signal processing time of approx. 1 ms, after which the new position data can be read via SSI or BiSS. Once the SET function has been triggered, the encoder requires an internal processing time of typ. 200 ms; during this time the supply voltage must not be switched off.</p> <p>The SET function should be carried out whilst the encoder is at rest.</p> <p>If this input is not used, it should be connected to 0 V (Encoder ground GND) in order to avoid interferences.</p>	

DIR input	
<p>Direction input: A HIGH signal switches the direction of rotation from the default cw to ccw. This inverted function can also be factory-programmed.</p> <p>If this input is not used, it should be connected to 0 V (Encoder ground GND) in order to avoid interferences.</p>	
Response time (DIR input)	1 ms

Power-ON
After Power-ON the device requires a time of approx. 150 ms before valid data can be read.
Hot plugging of the encoder should be avoided.

Approvals		
UL compliant in accordance with	File no. E224618	
CE compliant in accordance with	EMC Directive	2014/30/EU
	RoHS Directive	2011/65/EU

Absolute encoders – multiturn

**Compact
electronic multiturn, optical**

Sendix F3663 / F3683 (shaft / hollow shaft)

SSI / BiSS

Terminal assignment

Interface	Type of connection	Features	Cable (isolate unused cores individually before initial start-up)													
1, 2	1, 3, U	SET, DIR, Status	Signal:	0 V	+V	C+	C-	D+	D-	SET	DIR	Stat	⊥			
			Core color:	WH	BN	GN	YE	GY	PK	BU	RD	VT	shield			
1, 2	5	SET, DIR	M12 connector, 8-pin													
			Signal:	0 V	+V	C+	C-	D+	D-	SET	DIR	⊥				
			Pin:	1	2	3	4	5	6	7	8	PH				
3, 4	1, 3, U	SET, DIR, 2048 SinCos	Cable (isolate unused cores individually before initial start-up)													
			Signal:	0 V	+V	C+	C-	D+	D-	SET	DIR	A	\bar{A}	B	\bar{B}	⊥
			Core color:	WH	BN	GN	YE	GY	PK	BU	RD	BK	VT	GY-PK	RD-BU	shield
5	1, 3, U	SET, DIR, Sensor output	Cable (isolate unused cores individually before initial start-up)													
			Signal:	0 V	+V	C+	C-	D+	D-	SET	DIR	0 V _{sens}	+V _{sens}	⊥		
			Core color:	WH	BN	GN	YE	GY	PK	BU	RD	VT	RD-BU	shield		
6	1, 3, U	2048 SinCos, Sensor output	Cable (isolate unused cores individually before initial start-up)													
			Signal:	0 V	+V	C+	C-	D+	D-	0 V _{sens}	+V _{sens}	A	\bar{A}	B	\bar{B}	⊥
			Core color:	WH	BN	GN	YE	GY	PK	BU	RD	BK	VT	GY-PK	RD-BU	shield
7, 8	1, 3, U	2048 incr. RS422	Cable (isolate unused cores individually before initial start-up)													
			Signal:	0 V	+V	C+	C-	D+	D-	A	\bar{A}	B	\bar{B}	⊥		
			Core color:	WH	BN	GN	YE	GY	PK	BK	VT	GY-PK	RD-BU	shield		

- +V: Supply voltage encoder +V DC
- 0 V: Supply voltage encoder ground GND (0 V)
- 0 V_{sens} / +V_{sens}: Using the sensor outputs of the encoder, the voltage present can be measured and if necessary increased accordingly.
- C+, C-: Clock signal
- D+, D-: Data signal
- A, \bar{A} : Incremental output channel A (cosine)
- B, \bar{B} : Incremental output channel B (sine)
- SET: Set input
- DIR: Direction input
- Stat: Status output
- PH ⊥: Plug connector housing (shield)

Top view of mating side, male contact base



M12 connector, 8-pin

Absolute encoders – multiturn

**Compact
electronic multiturn, optical**

Sendix F3663 / F3683 (shaft / hollow shaft)

SSI / BiSS

Dimensions shaft version

Dimensions in mm [inch]

Clamping flange, \varnothing 36 [1.42]
Flange type 1 and 3

- 1 3 x M3, 6 [0.24] deep
- 2 Battery (in the cable)

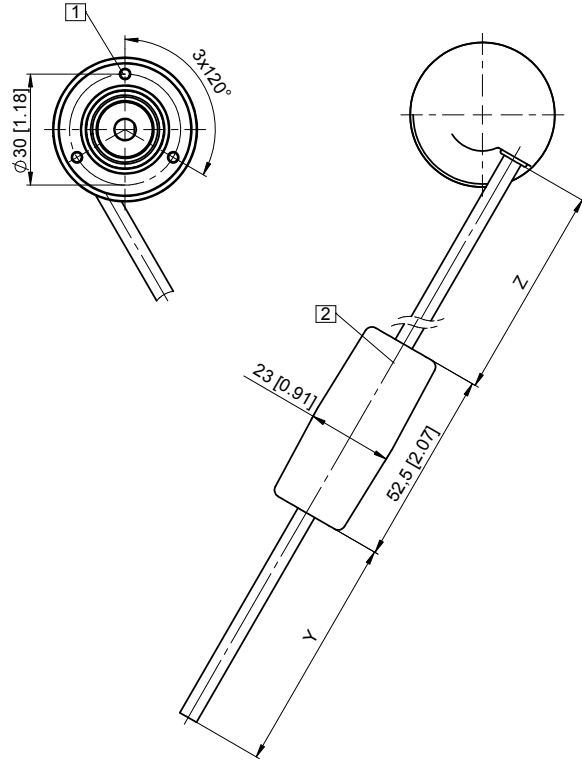
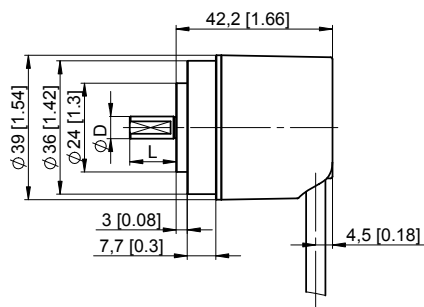

D	Fit	L
6 [0.24]	h7	12.5 [0.49]
8 [0.32]	h7	15 [0.59]
10 [0.39]	f7	20 [0.79]
1/4"	h7	12.5 [0.49]
3/8"	h7	5/8"

Y	Z
1 m [3.28']	0.15 m [0.49']
5 m [16.40']	0.15 m [0.49']

Synchro flange, \varnothing 36 [1.42]

Flange type 2 and 4
(drawing with cable)

- 1 4 x M3, 6 [0.24] deep
- 2 Battery (in the cable)

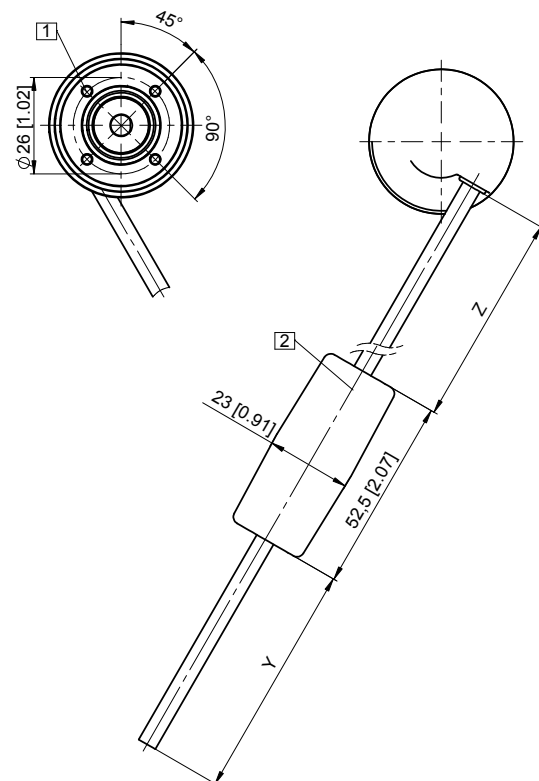
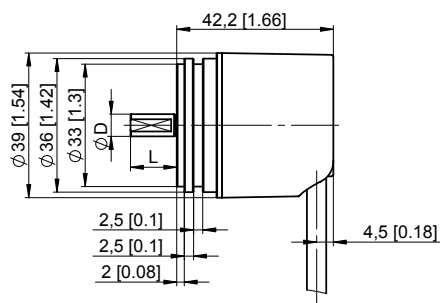

D	Fit	L
6 [0.24]	h7	12.5 [0.49]
8 [0.32]	h7	15 [0.59]
10 [0.39]	f7	20 [0.79]
1/4"	h7	12.5 [0.49]
3/8"	h7	5/8"

Y	Z
1 m [3.28']	0.15 m [0.49']
5 m [16.40']	0.15 m [0.49']

Absolute encoders – multitrurn

**Compact
electronic multitrurn, optical**

Sendix F3663 / F3683 (shaft / hollow shaft)

SSI / BiSS

Dimensions hollow shaft version

Dimensions in mm [inch]

Flange with spring element

Flange type 1 and 3

(drawing with spring element short, spring element long is shown dashed)

- 1 4 x M2.5, 5 [0.20] deep
- 2 Spring element, short recommendation: torque pin DIN 7, \varnothing 4 [0.16]
- 3 Spring element, long recommendation: torque pin DIN 7, \varnothing 4 [0.16]
- 4 Battery (in the cable)
- 5 Recommended torque for the clamping ring 0.6 Nm

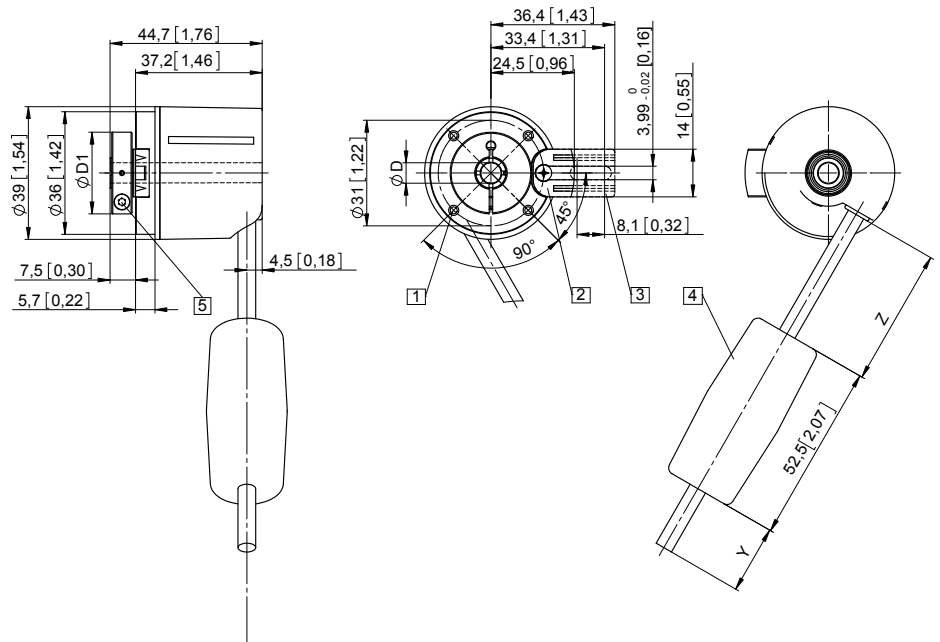

D	Fit	D1
6 [0.24]	H7	24 [0.94]
8 [0.32]	H7	25.5 [1.00]
10 [0.39] *)	H7	25.5 [1.00]
1/4"	H7	24 [0.94]

*) Blind hollow shaft, insertion depth max. = 14.5 mm [0.57"]

Y	Z
1 m [3.28']	0.15 m [0.49']
5 m [16.40']	0.15 m [0.49']

Flange with stator coupling, \varnothing 46 [1.81]

Flange type 2

- 1 Battery (in the cable)
- 2 Recommended torque for the clamping ring 0.6 Nm

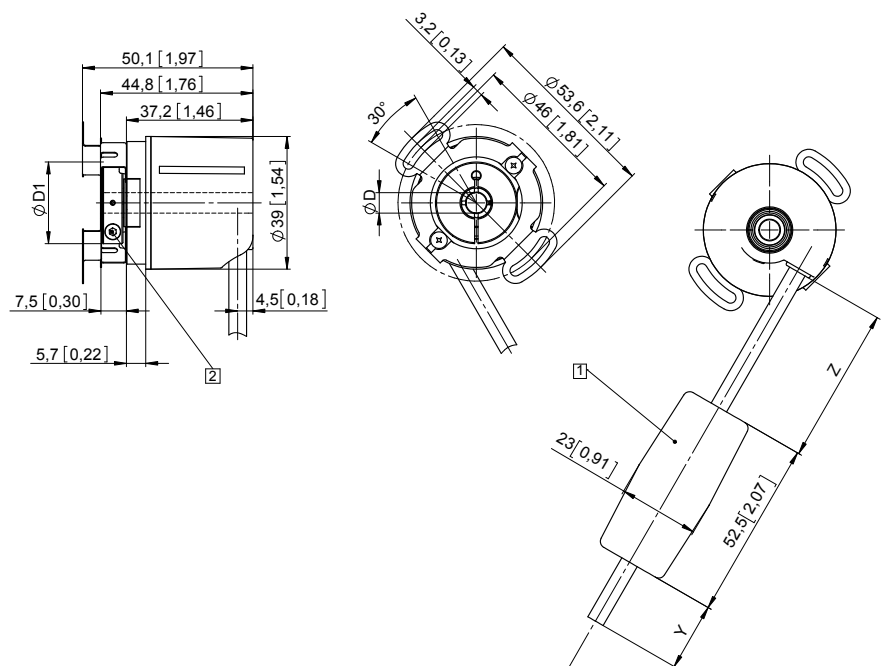

D	Fit	D1
6 [0.24]	H7	24 [0.94]
8 [0.32]	H7	25.5 [1.00]
10 [0.39] *)	H7	25.5 [1.00]
1/4"	H7	24 [0.94]

*) Blind hollow shaft, insertion depth max. = 14.5 mm [0.57"]

Y	Z
1 m [3.28']	0.15 m [0.49']
5 m [16.40']	0.15 m [0.49']