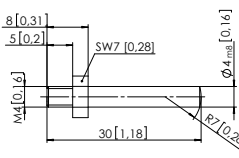

Absolute encoders – multiturn

Standard Motor-Line, electronic multiturn, optical	Sendix F5883M (hollow shaft)	SSI / BiSS + incremental
---	-------------------------------------	---------------------------------

Mounting accessory for hollow shaft encoders	Dimensions in mm [inch]	Order no.
Torque pin, ø 4 mm for flange with spring element (flange type 1)	with fixing thread 	8.0010.4700.0000

Further accessories can be found in the accessories section or in the accessories area of our website at: kuebler.com/accessories.
 Suitable connectors can be found in the connection technology section or in the connection technology area of our website at: kuebler.com/connection_technology.

Technical data

Mechanical characteristics	
Maximum speed	9000 min ⁻¹ , 6000 min ⁻¹ (continuous)
Starting torque at 20 °C [68 °F]	< 0.01 Nm
Mass moment of inertia	6.0 x 10 ⁻⁶ kgm ²
Load capacity of shaft	radial 80 N axial 40 N
Weight	approx. 0.45 kg [15.87 oz]
Protection	IP65
Working temperature range	-40 °C ... +85 °C [-40 °F ... +185 °F] ¹⁾
Material	hollow shaft stainless steel flange aluminum housing zinc die-cast cable PVC
Shock resistance acc. to EN 60068-2-27	2500 m/s ² , 6 ms
Vibration resistance acc. to EN 60068-2-6	100 m/s ² , 55 ... 2000 Hz

Electrical characteristics	
Supply voltage	5 V DC (+5%) or 10 ... 30 V DC
Current consumption (no load)	5 V DC max. 60 mA 10 ... 30 V DC max. 30 mA
Reverse polarity protection of the supply voltage	yes (at 10 ... 30 V DC)
Short circuit proof outputs	yes ²⁾

SSI interface	
Output driver	RS485 transceiver type
Permissible load / channel	max. +/- 30 mA
Signal level	HIGH typ 3.8 V LOW at I _{Load} = 20 mA typ 1.3 V
Resolution singleturn	10 ... 17 bit
Number of revolutions (multiturn)	max. 24 bit
Code	binary or gray
SSI clock rate	50 kHz ... 2 MHz
Data refresh rate	ST resolution ≤ 14 bit ≤ 1 μs ST resolution ≥ 15 bit 4 μs
Monoflop time	≤ 15 μs
Note: If the clock starts cycling within the monoflop time, a second data transfer starts with the same data. If the clock starts cycling after the monoflop time, the data transfer starts with the new values. The update rate is dependent on the clock speed, data length and monoflop-time.	

BiSS interface	
Output driver	RS485 transceiver type
Permissible load / channel	max. +/- 30 mA
Signal level	HIGH typ 3.8 V LOW at I _{Load} = 20 mA typ 1.3 V
Resolution singleturn	10 ... 17 bit
Number of revolutions (multiturn)	max. 24 bit
Code	binary
BiSS clock rate	50 kHz ... 10 MHz
Max. update rate	< 10 μs, depends on the clock rate and the data length
Data refresh rate	ST resolution ≤ 14 bit ≤ 1 μs ST resolution 17 bit 2.4 μs
Note:	– bidirectional, factory programmable parameters are: resolution, code, direction, alarms and warnings – CRC data verification

Status output and LED	
Output driver	open collector, internal pull up resistor 22 kOhm
Permissible load	max. 20 mA
Signal level	HIGH: +V / LOW: < 1 V
Active	LOW
The optional LED (red) and the status output serve to display various alarm or error messages. In normal operation the LED is OFF and the status output is HIGH (open collector with int. pull up 22 kOhm).	
An active status output (LOW) displays:	
– sensor error, singleturn or multiturn (soiling, glass breakage etc.)	
– LED fault (failure or ageing)	
– over- or under-temperature	
In the SSI mode, the fault indication can only be reset by switching off the power-supply to the device.	

Incremental outputs (A/B)		
	SinCos	RS422 TTL compatible
Max. frequency -3dB	400 kHz	400 kHz
Signal level	1 V _{pp} (±20 %)	HIGH: min. 2.5 V LOW: max. 0.5 V
Short circuit proof	yes ²⁾	yes ²⁾
Pulse rate	1024 / 2048 ppr	1024 / 2048 ppr

1) Temperature measured on the flange – max. 80 °C allowable on the cable (fixed installation).
 2) Short circuit to 0 V or to output; if supply voltage correctly applied.

Absolute encoders – multiturn

Standard Motor-Line, electronic multiturn, optical	Sendix F5883M (hollow shaft)	SSI / BiSS + incremental
---	-------------------------------------	---------------------------------

SET input	
Input	active HIGH
Input type	comparator
Signal level (+V = supply voltage)	HIGH min. 60 % of +V, max: +V LOW max. 30 % of +V
Input current	< 0.5 mA
Min. pulse duration (SET)	10 ms
Input Delay	1 ms
New position data readable after	1 ms
Internal processing time	200 ms

The encoder can be set to zero at any position by means of a HIGH signal on the SET input or by pressing the optional SET button (with a pencil, ball-point pen or similar). Other preset values can be factory-programmed. The SET input has a signal processing time of approx. 1 ms, after which the new position data can be read via SSI or BiSS. Once the SET function has been triggered, the encoder requires an internal processing time of typ. 200 ms; during this time the supply voltage must not be switched off.

The SET function should be carried out whilst the encoder is at rest.

If this input is not used, it should be connected to 0 V (Encoder ground GND) in order to avoid interferences.

DIR input	
Direction input: A HIGH signal switches the direction of rotation from the default cw to ccw. This inverted function can also be factory-programmed. If DIR is changed when the device is already switched on, then this will be interpreted as an error. The status output will switch to LOW.	
If this input is not used, it should be connected to 0 V (Encoder ground GND) in order to avoid interferences.	
Response time (DIR input)	1 ms

Approvals	
UL compliant in accordance with	File no. E224618
CE compliant in accordance with	
EMC Directive	2014/30/EU
RoHS Directive	2011/65/EU

Power-ON	
After Power-ON the device requires a time of approx. 150 ms before valid data can be read.	
Hot plugging of the encoder should be avoided.	

Terminal assignment

Interface	Type of connection	Features	Cable (isolate unused cores individually before initial start-up)
1, 2	E, F	SET, DIR, Status	Signal: 0 V +V C+ C- D+ D- SET DIR Stat N/C N/C N/C \perp
			Core color: WH BN GN YE GY PK BU RD BK - - - shield
5	E, F	SET, DIR, Status sensor output	Signal: 0 V +V C+ C- D+ D- SET DIR Stat N/C 0Vsens +Vsens \perp
			Core color: WH BN GN YE GY PK BU RD BK - GY-PK RD-BU shield
3, 4, 7, 8, A, B	E F	SET, DIR, SinCos or incr. RS422	Signal: 0 V +V C+ C- D+ D- SET DIR A \bar{A} B \bar{B} \perp
			Core color: WH BN GN YE GY PK BU RD BK VT GY-PK RD-BU shield
6	E, F	SinCos or incr. RS422 sensor output	Signal: 0 V +V C+ C- D+ D- A \bar{A} B \bar{B} 0Vsens +Vsens \perp
			Core color: WH BN GN YE GY PK BU RD BK VT GY-PK RD-BU shield

- +V: Supply voltage encoder +V DC
- 0 V: Supply voltage encoder ground GND (0 V)
- 0 Vsens / +Vsens: Using the sensor outputs of the encoder, the voltage present can be measured and if necessary increased accordingly.
- C+, C-: Clock signal
- D+, D-: Data signal
- A, \bar{A} : Incremental output channel A (cosine)
- B, \bar{B} : Incremental output channel B (sine)
- SET: Set input
- DIR: Direction input
- Stat: Status output
- PH \perp : Plug connector housing (shield)

Absolute encoders – multiturn

Standard
Motor-Line, electronic multiturn, optical

Sendix F5883M (hollow shaft)

SSI / BiSS + incremental

Dimensions hollow shaft version

Dimensions in mm [inch]

Flange with spring element, long Flange type 1

- 1 Slot spring element, recommendation: torque pin DIN 7, ϕ 4 [0.16]
- 2 3 x M3, 6 [0.24] deep
- 3 Recommended torque for the clamping ring 0.6 Nm
- 4 Status-LED
- 5 SET button

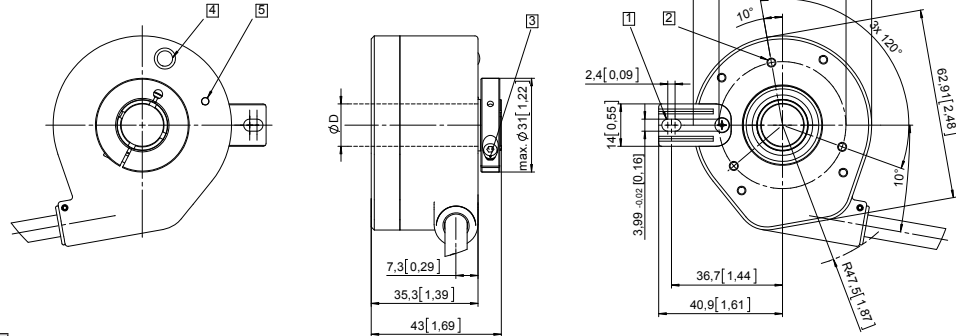

D	Fit
10 [0.39]	H7
12 [0.47]	H7
14 [0.55]	H7
15 [0.59]	H7
1/2 "	H7

Flange with stator coupling, ϕ 63 [2.48]

Flange type 5

Pitch circle diameter for fixing screws 63 mm [2.48]

- 1 Recommended torque for the clamping ring 0.6 Nm
- 2 Status-LED
- 3 SET button

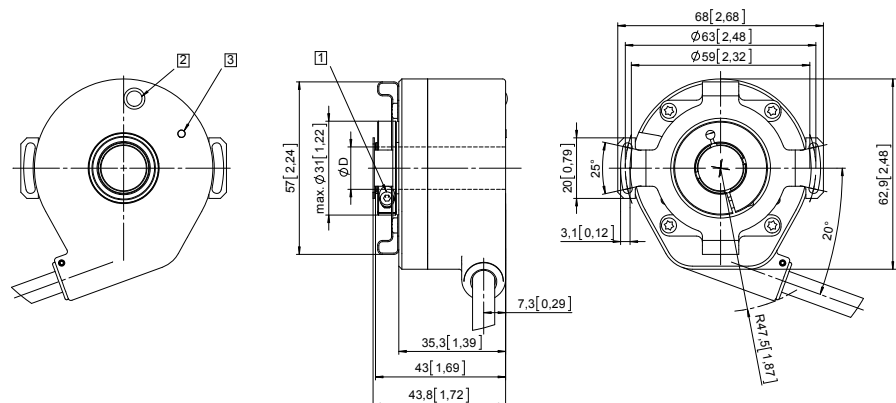

D	Fit
10 [0.39]	H7
12 [0.47]	H7
14 [0.55]	H7
15 [0.59]	H7
1/2 "	H7

Flange with torque stop, flexible

Flange type 9

- 1 Recommended torque for the clamping ring 0.6 Nm
- 2 Status-LED
- 3 SET button

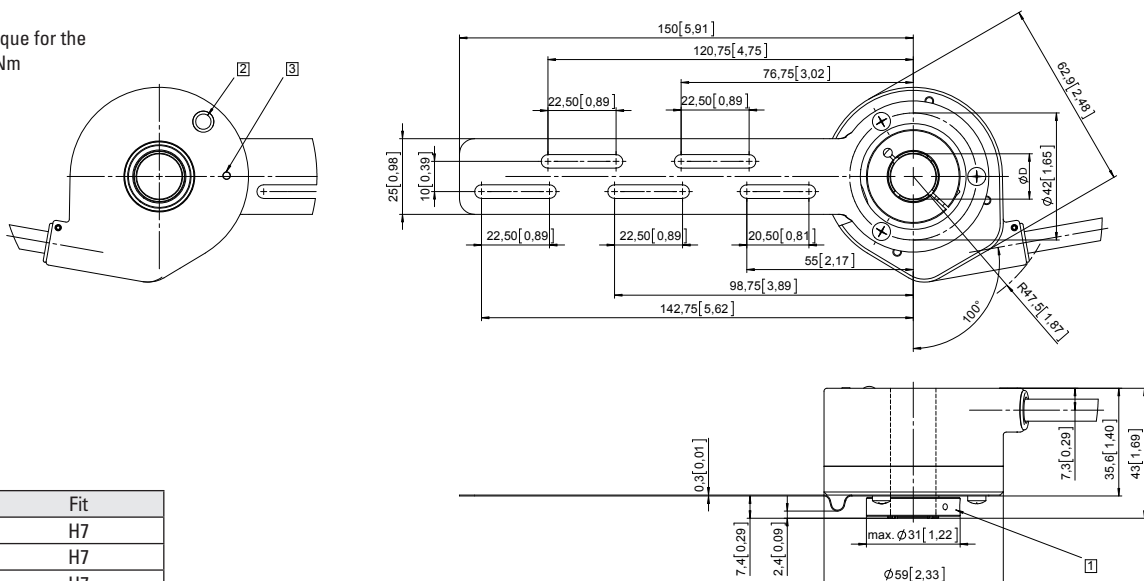

D	Fit
10 [0.39]	H7
12 [0.47]	H7
14 [0.55]	H7
15 [0.59]	H7
1/2 "	H7