

# Incremental encoders

<b>Heavy Duty hollow shaft, optical</b>	<b>Sendix Heavy Duty H120 (hollow shaft)</b>	<b>Push-pull / RS422</b>
---	--	--------------------------



The Sendix Heavy Duty H120 were especially developed for large motors and generators. They are highly accurate and extremely robust thanks to HD-Safety-Lock™ – the Heavy Duty hollow shaft design of the latest generation with sturdy bearing construction and integrated bearing isolation. The dual protection of the shaft, the wide temperature range and the high protection level allow for use even under the harshest conditions.

The very large hollow shaft up to 28 mm plus the wide variety of mounting solutions and connection options offer the very highest degree of flexibility during installation.

HD-Safety-Lock™	2.5 kV bearing isolation	Dual protection of the shaft	Temperature range -40° ... +100°C	High protection level IP67	Shock/vibration resistant	Terminal box rotatable - 180°	Plug-in cage-clamp connectors	Hollow shaft up to ø 28 mm	Optical sensor	Seawater durable

## Robust

- Integrated bearing isolation up to 2.5 kV for reliable shaft connection. <sup>1)</sup>
- Extremely high resilience as a result of dual protection of the shaft (shielding cover disk and radial shaft seal), protection level IP67 as well as a seawater durable housing.
- High shock (200 g) and vibration (15 g) resistance.

## Flexible

- 3 fixing solutions: conical central fastening, cylindrical central fastening or through hollow shaft.
- Connection via cable, M12 or M23 connector or terminal box.
- Torque stop on the flange or the cover – allows the device to be rotated as required during mounting.
- Through hollow shaft up to ø 28 mm.

## Order code Hollow shaft version

8.H120	.	XXXXX	.	XXXX
Type		a b c d		e

<p><b>a Flange</b></p> <p>1 = without mounting aid                  2 = with fastening arm 70 mm [2.76"] <sup>2)</sup>                  3 = with fastening arm 100 mm [3.93"] <sup>2)</sup>                  4 = with fastening arm 150 mm [5.91"] <sup>2)</sup>                  5 = with stator coupling, ø 119 mm [4.69"]</p> <p><b>b Through hollow shaft</b></p> <p>2 = ø 16 mm [0.63"]                  3 = ø 20 mm [0.79"]                  5 = ø 25 mm [0.98"]                  7 = ø 28 mm [1.10"]                  6 = ø 1"</p> <p><i>Blind hollow shaft, with central fastening insertion depth max. 53 mm [2.09"]</i></p> <p>A = ø 12 mm [0.47"]                  B = ø 16 mm [0.63"]</p> <p><i>Blind hollow shaft, cone with central fastening insertion depth max. 22.5 mm [0.89"]</i></p> <p>K = ø 17 mm [0.67"], 1 : 10</p>	<p><b>c Output circuit / supply voltage</b></p> <p>4 = RS422 (with inverted signal) / 5 V DC                  1 = RS422 (with inverted signal) / 10 ... 30 V DC                  5 = push-pull (with inverted signal) / 10 ... 30 V DC                  6 = push-pull (with inverted signal) / 10 ... 30 V DC, power version up to 350 m</p> <p><b>d Type of connection</b></p> <p>1 = radial cable, 1 m [3.28'] PVC                  A = radial cable, special length PVC *)                  2 = radial M12 connector, 8-pin, ccw                  4 = radial M23 connector, 12-pin, ccw                  D = radial M23 connector, 12-pin, cw                  K = terminal box with plug-in spring terminal connectors, rotatable through 180°</p> <p>*) Available special lengths (connection type A):                  2, 3, 5, 8, 10, 15 m [6.56, 9.84, 16.40, 26.25, 32.80, 49.21']                  order code expansion .XXXX = length in dm                  ex.: 8.H120.121A.2048.0030 (for cable length 3 m)</p>	<p><b>e Pulse rate</b></p> <p>50, 360, 512, 600, 1000, 1024, 1500, 2000, 2048, 2500, 4096, 5000                  (e.g. 360 pulses =&gt; 0360)</p> <p><i>Optional on request</i>                  - other pulse rates                  - Ex 2/22 <sup>3)</sup></p>
---	---	---

1) With a shaft diameter > 32 mm [1.26"] the insulation resistance of 2.5 kV cannot be guaranteed.  
 2) Enclosed, not mounted.  
 3) For the cable connection type, cable material PUR.

# Incremental encoders

Heavy Duty hollow shaft, optical	Sendix Heavy Duty H120 (hollow shaft)	Push-pull / RS422
<b>Cables and connectors</b>		Order no.
<b>Preassembled cables</b>	M12 female connector with coupling nut, 8-pin, A coded, straight Single-ended 2 m [6.56'] PVC cable	<b>05.00.6041.8211.002M</b>
	M23 female connector with coupling nut, 12-pin, cw Single-ended 2 m [6.56'] PVC cable	<b>8.0000.6201.0002</b>
<b>Connectors</b>	M12 female connector with coupling nut, 8-pin, A coded, straight (metal)	<b>05.CMB 8181-0</b>
	M23 female connector with coupling nut, 12-pin, cw <sup>1)</sup>	<b>8.0000.5012.0000</b>

Further Kübler accessories can be found at: [kuebler.com/accessories](http://kuebler.com/accessories)  
 Further Kübler cables and connectors can be found at: [kuebler.com/connection-technology](http://kuebler.com/connection-technology)

## Technical data

Mechanical characteristics	
<b>Maximum speed</b>	6000 min <sup>-1</sup> at 60 °C [140 °F] 3500 min <sup>-1</sup>
<b>Starting torque – at 20 °C [68 °F]</b>	0.05 Nm
<b>Load capacity of shaft</b>	radial 475 N axial 375 N
<b>Weight</b>	1.6 ... 2.0 kg [56.44 ... 70.55 oz] (depending on version)
<b>Protection acc. to EN 60529</b>	IP67
<b>Working temperature range</b>	-40 °C <sup>2)</sup> ... +100 °C <sup>3)</sup> [-40 °F <sup>3)</sup> ... +212 °F <sup>3)</sup>
<b>Materials</b>	shaft stainless steel, bore tolerance H7 housing, flange seawater durable
<b>Shock resistance acc. to EN 60068-2-27</b>	2000 m/s <sup>2</sup> , 6 ms
<b>Vibration resistance acc. to EN 60068-2-6</b>	150 m/s <sup>2</sup> , 10 ... 2000 Hz

Approvals	
<b>CE compliant</b> in accordance with	
EMC Directive	2014/30/EU
RoHS Directive	2011/65/EU
ATEX Directive	2014/34/EU (for Ex 2/22 variants)

Electrical characteristics			
Output circuit	RS422 (TTL-compatible))	Push-pull	Push-pull (power version)
<b>Supply voltage</b>	5 V DC (±5 %) or 10 ... 30 V DC	10 ... 30 V DC	10 ... 30 V DC
<b>Power consumption (no load)</b>	max. 90 mA	max. 80 mA	max. 90 mA
<b>Permissible load per channel</b>	DC max. +/- 20 mA peak max. +/- 30 mA	max. +/- 30 mA max. +/- 70 mA	max. +/- 150 mA max. +/- 200 mA
<b>Pulse frequency</b>	max. 300 kHz	max. 300 kHz	max. 300 kHz
<b>Max. cable length</b>	550 m at 100 kHz	150 m at 80 kHz	350 m at 100 kHz
<b>Signal level</b>	HIGH min. 2.5 V LOW max. 0.5 V	min. +V - 3.0 V max. 2.5 V	min. +V - 4.0 V max. 3.0 V
<b>Rising edge time t<sub>r</sub></b>	max. 200 ns	max. 1 µs	max. 1 µs
<b>Falling edge time t<sub>f</sub></b>	max. 200 ns	max. 1 µs	max. 1 µs
<b>Short circuit proof outputs <sup>4)</sup></b>	yes	yes	yes
<b>Reverse polarity protection of the supply voltage</b>	yes	yes	yes
<b>CE compliant acc. to</b>	EMC guideline 2014/30/EU RoHS guideline 2011/65/EU		

1) Suitable for connection type 4.  
 2) With connector: -40 °C [-40 °F], with securely installed cable: -30 °C [-22 °F],  
 with flexibly installed cable: -20 °C [-4 °F].  
 3) Measured at the flange.  
 4) If supply voltage correctly applied.

# Incremental encoders

<b>Heavy Duty hollow shaft, optical</b>	<b>Sendix Heavy Duty H120 (hollow shaft)</b>	<b>Push-pull / RS422</b>
---	--	--------------------------

## Terminal assignment

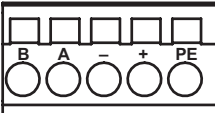
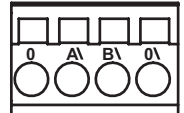
Output circuit	Type of connection	Cable (isolate unused cores individually before initial start-up)												
1, 4, 5, 6	1, A	Signal:	0 V	+V	0 Vsens	+Vsens	A	$\bar{A}$	B	$\bar{B}$	0	$\bar{0}$	$\perp$	
		Core color:	WH	BN	GY PK	RD BU	GN	YE	GY	PK	BU	RD	Shield	
Output circuit	Type of connection	M12 connector, 8-pin												
1, 4, 5, 6	2	Signal:	0 V	+V	0 Vsens	+Vsens	A	$\bar{A}$	B	$\bar{B}$	0	$\bar{0}$	$\perp$	
		Pin:	1	2	-	-	3	4	5	6	7	8	PH <sup>1)</sup>	
Output circuit	Type of connection	M23 connector, 12-pin												
1, 4, 5, 6	4, D	Signal:	0 V	+V	0 Vsens	+Vsens	A	$\bar{A}$	B	$\bar{B}$	0	$\bar{0}$	$\perp$	
		Pin:	10	12	11	2	5	6	8	1	3	4	PH <sup>1)</sup>	
Output circuit	Type of connection	Terminal connections												
1, 4, 5, 6	K	Signal:	B	A	0 V	+V	$\perp$	0	$\bar{A}$	$\bar{B}$	$\bar{0}$			
		Pin:	B	A	-	+	PE	0	$\bar{A}$	$\bar{B}$	$\bar{0}$			
														

- +V: Supply voltage encoder +V DC
- 0 V: Supply voltage encoder ground GND (0 V)
- 0 Vsens / +Vsens: Using the sensor outputs of the encoder, the voltage present can be measured and if necessary increased accordingly.
- A,  $\bar{A}$ : Incremental output channel A
- B,  $\bar{B}$ : Incremental output channel B
- 0,  $\bar{0}$ : Reference signal
- PH  $\perp$ : Plug connector housing (shield)

### Top view of mating side, male contact base

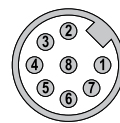

M12 connector, 8-pin, ccw

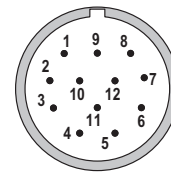

M23 connector, 12-pin, ccw

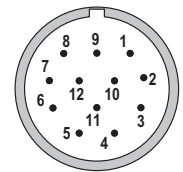

M23 connector, 12-pin, cw

1) PH = shield is attached to connector housing.



# Incremental encoders

## Heavy Duty hollow shaft, optical Sendix Heavy Duty H120 (hollow shaft) Push-pull / RS422

### Dimensions

Dimensions in mm [inch]

**Flange with fastening arm**  
**Blind hollow shaft with central fastening,**  
**cone,  $\phi$  17 [0.67], 1 : 10**  
**(blind hollow shaft, cone type K)**

- 1 3 x M4, 7 [0.28] deep
- 2 8 x M3, 8 [0.31] deep
- 3 6 x M4
- 4 Recommended torque for M6 (SW5) 5 - 6 Nm

Shaft connection to the application

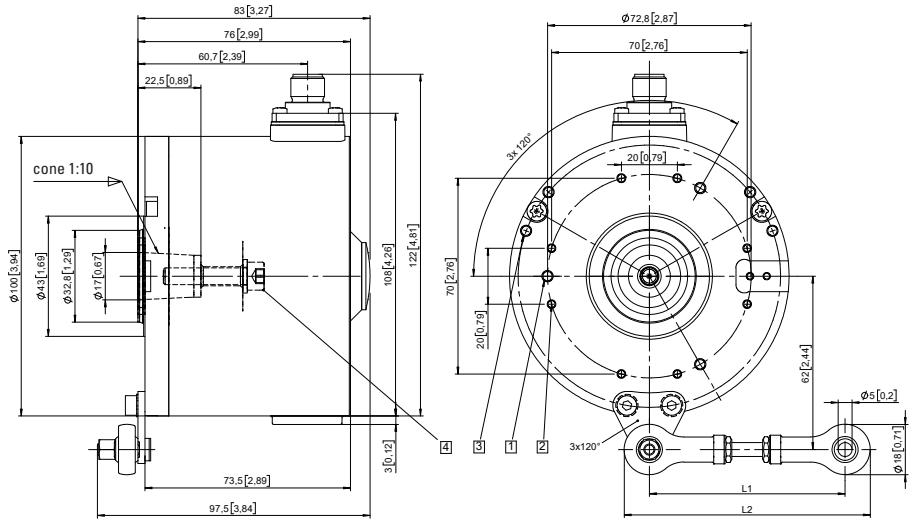
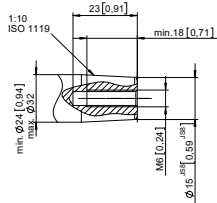

Fastening arm	L1	L2
70 mm [2.76]	64 ... 74 [2.51 ... 2.91]	82 ... 92 [3.23 ... 3.62]
100 mm [3.93]	94 ... 104 [3.70 ... 4.09]	112 ... 122 [4.41 ... 4.80]
150 mm [5.91]	144 ... 154 [5.67 ... 6.06]	162 ... 172 [6.38 ... 6.77]

**Flange with fastening arm**  
**Through hollow shaft and**  
**terminal box**

- 1 3 x M4, 7 [0.28] deep
- 2 8 x M3, 8 [0.31] deep
- 3 6 x M4
- 4 Recommended torque for the clamping ring 2 Nm (SW3)

Shaft connection to the application

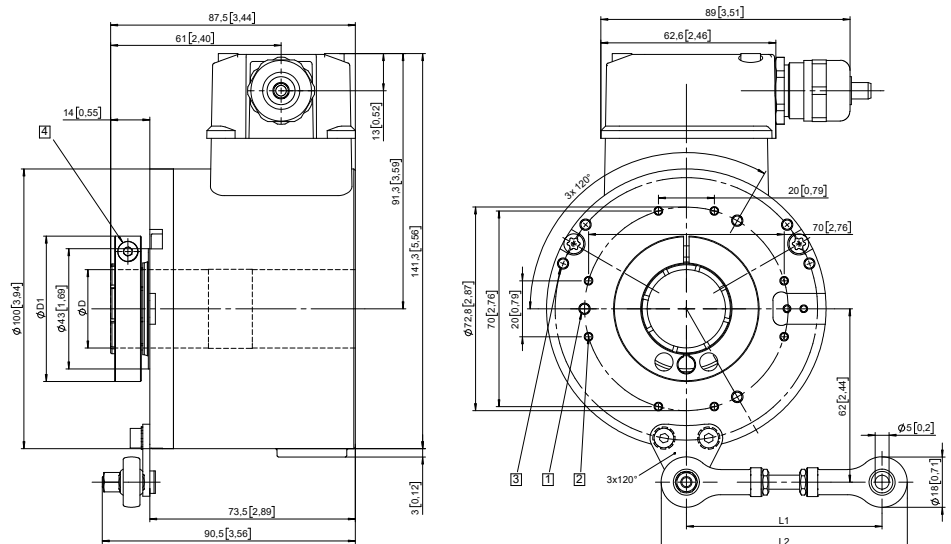
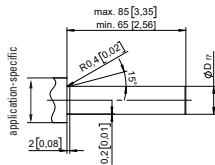

D	Fit	D1
16 [0.63]	H7	42.0 [1.65]
20 [0.79]	H7	42.0 [1.65]
25 [0.98]	H7	47.5 [1.87]
28 [1.10]	H7	52.0 [2.05]
1"	H7	47.5 [1.87]

Fastening arm	L1	L2
70 mm [2.76]	64 ... 74 [2.51 ... 2.91]	82 ... 92 [3.23 ... 3.62]
100 mm [3.93]	94 ... 104 [3.70 ... 4.09]	112 ... 122 [4.41 ... 4.80]
150 mm [5.91]	144 ... 154 [5.67 ... 6.06]	162 ... 172 [6.38 ... 6.77]