

Linear measuring technology

Absolute magnetic measurement system sensor head, magnetic band	Limes LA50 / BA5	Measuring length max. 20 m Resolution min. 10 µm
--	-------------------------	---



The non-contact absolute magnetic linear measurement system Limes LA50 / BA5 - made up of the sensor head LA50 and of the magnetic band BA5 - reaches a resolution up to 10 µm with a maximum distance of 1.5 mm between the sensor and the band.



 DC 10 ... 30 V	 20 m	 1,5 mm	 4 m/s	 0,01 mm	 IP40	 Reverse polarity protection	 Shock / vibration resistant	 -10°...+70°C	 Magnetic sensor
Supply voltage	Max. measuring length	Max. distance to measuring tape	Max. speed	High resolution	Protection			Temperature range	

Robust and versatile

- Resolution 0.01 mm / measuring lengths max. 20 m.
- Rugged die-cast zinc housing.
- Positions changes are also detected when de-energized no referencing movement required – no wear.
- Automatic distance detection in case of too high distance between the sensor and the magnetic band.
- Masking tape protecting the magnetic band.
- Address, baud rate, bus termination can be modified via microswitches.
- Interfaces: SSI, CANopen.

Easy installation

- Simple glued assembly of the magnetic band.
- Large mounting tolerances.
- Requires very little installation space.
- LED warning signals in case of too weak magnetic field.

Order code sensor head Limes LA50	8.LA50 . 1 2 X 1 Type a b c d
--	--

- | | | |
|--|--|---|
| <p>a Model
1 = IP40, standard</p> <p>b baud rate
2 = standard (CANopen, 250 k)</p> | <p>c Output circuit / supply voltage
1 = SSI 25 bit / 10 ... 30 V DC
3 = CANopen / 10 ... 30 V DC</p> | <p>d Type of connection
1 = cable, 1.5 m PUR</p> |
|--|--|---|

Order code magnetic band Limes BA5	8.BA5 . 20 . 010 . XXXX Type a b
---	--

- | | | | | | | | | | |
|--------------------------------------|---|------------|------------|------------|-------------|------------|-------------|------------|--|
| <p>a Width
20 = 20 mm</p> | <p>b Length (measuring range = length - 0.1 m)</p> <table border="0"> <tr> <td>0010 = 1 m</td> <td>0060 = 6 m</td> </tr> <tr> <td>0020 = 2 m</td> <td>0100 = 10 m</td> </tr> <tr> <td>0040 = 4 m</td> <td>0200 = 20 m</td> </tr> <tr> <td>0050 = 5 m</td> <td></td> </tr> </table> | 0010 = 1 m | 0060 = 6 m | 0020 = 2 m | 0100 = 10 m | 0040 = 4 m | 0200 = 20 m | 0050 = 5 m | |
| 0010 = 1 m | 0060 = 6 m | | | | | | | | |
| 0020 = 2 m | 0100 = 10 m | | | | | | | | |
| 0040 = 4 m | 0200 = 20 m | | | | | | | | |
| 0050 = 5 m | | | | | | | | | |

Linear measuring technology

Absolute magnetic measurement system sensor head, magnetic band	Limes LA50 / BA5	Measuring length max. 20 m Resolution min. 10 µm
--	-------------------------	---

Accessories	Order no.
SSI display type 570T Position display, 8-digit	with 2 relay outputs and serial interface DC supply voltage 6.570T.010.300
	with 4 fast switch outputs and serial interface AC/DC supply voltage 6.570T.012.E01
	with 4 fast switch outputs, serial interface and scalable analog output AC/DC supply voltage 6.570T.012.E02
	with 4 fast switch outputs and RS485 interface AC/DC supply voltage 6.570T.012.E03

Further accessories can be found in the accessories section or in the accessories area of our website at: www.kuebler.com/accessories.
Additional connectors can be found in the connection technology section or in the connection technology area of our website at: www.kuebler.com/connection_technology.

Technical data

Mechanical characteristics	
Weight	ca. 0.19 kg [6.70 oz]
Working temperature	-10 °C ... +70 °C [+14 °F ... +158 °F] (non condensing)
Storage temperature	-25 °C ... +85 °C [-13 °F ... +185 °F]
Protection acc. to EN 60529	IP40
Housing	zinc die-cast
Max. traverse speed permanent absolute positions reading	4 m/s
Shock resistance acc. to EN 60068-2-27	5000 m/s ² , 1 ms
Vibration resistance acc. to EN 60068-2-6	300 m/s ² , 10 ... 2000 Hz
Distance sensor head / magnetic band	0.1 ... 1.5 mm incl. masking tape (recommended 0.5 mm)
Measuring length	max. 20 m
Type of connection (standard)	cable, 1.5 m PUR, open cable ends

Electrical characteristics	
Supply voltage	10 ... 30 V DC ±10%
Residual ripple	< 10 %
Current consumption	max. 150 mA
Reverse polarity protection	yes
Short circuit proof	yes

Accuracy	
Measuring principle	absolute
System accuracy at 20 °C [+68 °F]	max. ± (150 + 20 × L) µm L = measuring length in meters
Repeat accuracy	±1 increment
Resolution	0.01 mm
LED, red	lights up when distance too large

SSI interface	
Output driver	RS485 transceiver type
Permissible load / channel	max. ±20 mA
Signal level	HIGH typ. 3.8 V LOW at I _{Load} = 20 mA typ. 1.3 V
Clock rate	25 bit (24 + 1 failurebit for distance)
Code	binary / gray (default) switchable
SSI clock rate	80 kHz ... 0.25 MHz
Monoflop time	≤ 40 µs
Data refresh rate	≤ 1 ms

CANopen interface	
Interface	CAN High-Speed acc. to ISO 11898, Basic and Full CAN, CAN specification 2.0 B
Protocol	CANopen
Baud rate	125 ... 1000 kbit/s adjustable with a rotary switch
Termination	yes/no with a rotary switch
Node address	1 ... 15 configurable (default 1)
LSS protocol	CIA LSS protocol DS305 global command support for node address and baud rate selective commands via attributes of the identity object

Approvals	
CE compliant in accordance with	EMC Directive 2014/30/EU RoHS Directive 2011/65/EU

Linear measuring technology

Absolute magnetic measurement system sensor head, magnetic band	Limes LA50 / BA5	Measuring length max. 20 m Resolution min. 10 µm
--	-------------------------	---

Magnetic band Limes BA5	
Pole gap	basic pole pitch 5 mm
Dimensions	width 20 mm
	thickness 1.8 mm incl. masking tape
Relative linear expansion	$\Delta L = L \times \alpha \times \Delta\delta$ L = measuring length in meters $\alpha = 16 \times 10^{-6} 1/K$ temperature coefficient $\Delta\delta$ = relative temperature change based on 20 °C [+68 °F] in °K

Working temperature	-20 °C ... +80 °C [-4 °F ... +176 °F] ¹⁾
Mounting	adhesive joint
Additional length	100 mm in order to obtain an optimal measuring result, the magnetic band should be about 0.1 m longer than the required measuring length
Min. bending radius for storage	≥ 150 mm
Material metal tape	precision steel strip 1.4404 acc. to EN 10088-3

Terminal assignment

Output circuit	Type of connection	Cable										
1 (SSI)	1	Signal:	0 V	+V	D+	D-	C+	C-	-	-	⊥	
		Core color:	WH	BN	YE	OR	GN	VT	GY	BK	shield ²⁾	

Output circuit	Type of connection	Cable										
3 (CANopen)	1	Signal:	0 V	+V	CAN_H	CAN_L	-	-	-	-	⊥	
		Core color:	WH	BN	YE	OR	GN	VT	GY	BK	shield ²⁾	

- +V: Supply voltage encoder +V DC
- 0 V: Supply voltage encoder ground GND (0V)
- C+, C-: Clock signal
- D+, D-: Data signal

1) Magnetic band (ends) attached by screwing, clamping or equivalent.
 2) Connect shielding only machine side

Linear measuring technology

Absolute magnetic measurement system
Sensor head, magnetic band

Limes LA50 / BA5

Measuring length max. 20 m
Resolution min. 10 µm

Permissible mounting tolerances

Dimensions in mm [inch]

Distance sensor head / magnetic band (incl. masking tape)

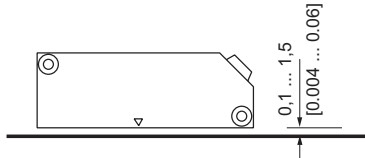

Torsion

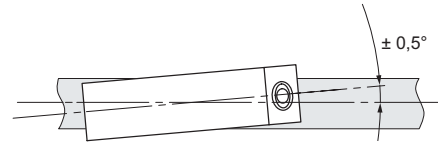

Tilting

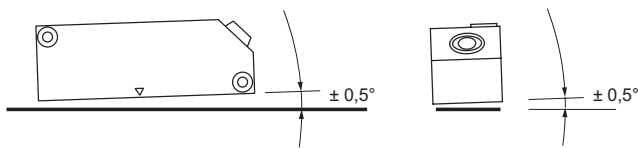

Offset

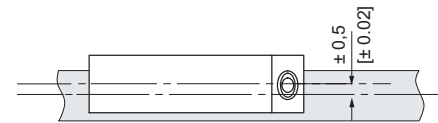

Measuring range

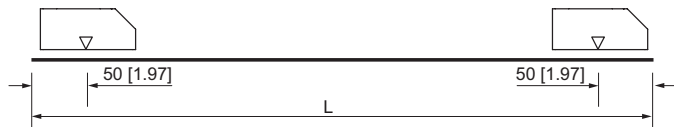

Observe mounting direction



Dimensions

Dimensions in mm [inch]

Sensor head Limes LA50

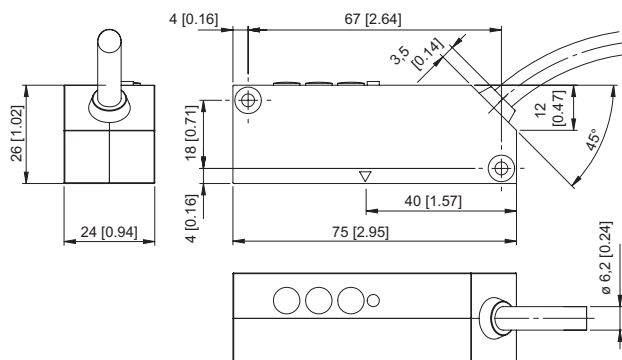

Magnetic band Limes BA5

- 1 Length L, max. 20 m
- 2 Masking tape
- 3 Magnetic band

