

Shaft copying systems

Sensor – Ants Base	LEB02	Absolute position detection
---------------------------	--------------	------------------------------------



Ants LEB02 is an extremely robust, compact and contactless measuring system. It uses a contactless measuring principle to measure without any slipping absolute elevator car positions with a resolution of 1 mm and a travel speed of 8 m/s. Additional components such as magnetic switches become superfluous.

Especially the easy assembly reduces installation time, thus contributing to overall costs reduction.



Features and benefits

- Precise position feedback**
 The sensor system provides absolute position values. No homing necessary after power failure.
- 100 % slip-free**
 Mounting on, next to or underneath the lift car always provides direct position feedback without the effect of possible slippage of the suspension means.
- Conveyor heights up to 392 m**
 With a resolution of 1 mm, a travel speed of up to 8 m/s and a maximum code band length of 392 m the measuring system can also be used for high-rise installations.
- Maximum compactness**
 With its compactness, the sensor is not only easy to install, but can also be integrated into the tightest installation spaces. Even in glass lifts, it blends in very well with the overall appearance of the lift system.

Functional principle LEB02

The Ants LEB02 sensor consists of a detection system (SCAN). Positions and speeds are detected without slippage and transmitted to a controller via CANOpen Lift, SSI or RS485.



Shaft copying systems

Sensor – Ants Base LEB02 Absolute position detection

Required components for the use of the LEB02 sensor

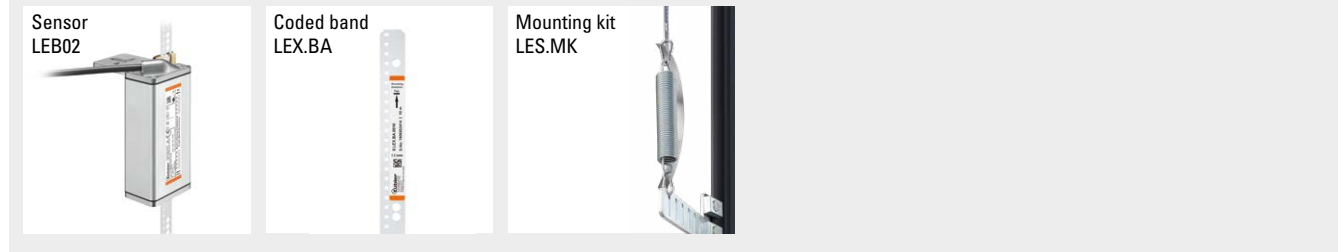

Order code 8.LEB02.X1XX.XX11

Sensor Type a b c d

- a** *Type of mounting*
1 = with mounting plate
2 = without mounting plate ¹⁾
 - b** *Interface / supply voltage*
2 = CANopen / 10 ... 30 V
3 = RS485 / 10 ... 30 V
4 = SSI / 10 ... 30 V
 - c** *Type of connection*
1 = cable, 3 m [9.84'], open cable end
2 = cable, 3 m [9.84'], shielded, male connector 9-pin ²⁾
A = cable, special lengths, shielded, open cable end ^{*)}
B = cable, special lengths, shielded, Sub-D male contacts, 9-pin ^{*)} ²⁾
 - d** *Interface profile ³⁾*
22 = CANopen Lift, DS417 V2.2.8
31 = RS485, 9 Byte, 24 bit position data
41 = SSI, Gray, 25 bit
- ^{*)} Special lengths on request: 5 m, 7 m, 10 m
order code expansion .XXXX = length in dm
ex.: 8.LEB02.112A.2211.0050 (for cable length 5 m)

Order code 8.LEX.BA.XXXX

Coded band, absolute Type a

- a** *Measuring lengths*
XXXX = lengths in meters
(max. length = 392 m)
- Standard lengths*
0010 = 10 m 0040 = 40 m 0090 = 90 m
0015 = 15 m 0050 = 50 m 0100 = 100 m
0020 = 20 m 0060 = 60 m 0392 = 392 m
0025 = 25 m 0070 = 70 m Intermediate lengths < 100 m as from 5 pieces,
0030 = 30 m 0080 = 80 m > 100 m on request
- Stock types*
0010 = 10 m 0030 = 30 m
0015 = 15 m 0040 = 40 m
0020 = 20 m 0392 = 392 m
0025 = 25 m

Mounting kit 8.LEB.MK.XXXX

LEB.MK Type a [To the data sheet >](#)

- a** *Mounting type*
0001 = rail fastening
0005 = rail fastening 90°
0004 = dowel fastening

Accessories Order no.

EMC - Shield terminal For an EMC-compliant installation of the cable **8.0000.4G06.0312**

1) T-slot mounting.
2) With interface RS485 (b = 3) on request.

3) Selection depending on selected interface **d** :
CANopen can only be combined with **b** = 2
RS485 can only be combined with **b** = 3
SSI can only be combined with **b** = 4

Shaft copying systems

Sensor – Ants Base	LEB02	Absolute position detection
---------------------------	--------------	------------------------------------

Technical data

Mechanical characteristics	
Code	absolute, 16 bit
Max. measuring length	392 m
Speed	8 m/s
Resolution	1 mm
Accuracy	± 1 mm
Type of connection	cable 3 m with open end further lengths up to max. 10 m on request
Weight	550 g [19.4 oz]
Housing (material)	aluminum
Dimensions	L x W x H 126 x 55 x 37 mm [4.96 x 2.17 x 1.46"]

Electrical characteristics	
Supply voltage	10 ... 30 V DC
Reverse polarity protection	yes
Power consumption	max. 100 mA
Interfaces	CANopen Lift, RS485, SSI

Environmental conditions	
Protection acc. to EN 60529	IP54
Humidity	< 90 % (non-condensing)
Working temperature	-10 °C ... +70 °C [+14 °F ... +158 °F]
Storage temperature	-20 °C ... +80 °C [-4 °F ... +176 °F]
Air pressure (operating altitude)	800 ... 1013 hPA (up to 2000 m above NN)

Interface characteristics RS485	
Baud rate	19.200
Number of data bits	8 bit
Number of Start bits	1 bit
Number of Stop bits	1 bit
Parity	none
Repetition	150 Hz
Number of bytes / transmission	9 bytes
Resolution position	1 mm
Resolution speed	10 mm/s
Position value	24 bit, binary
Speed value	16 bit, two's complement

Interface characteristics CANopen Lift (standard factory setting)	
Bitrate	250 kbit/s
Identifier	0x18C
Node ID	0x04
Eventtimer	10 ms
Resolution	1 mm
Heartbeat	500 ms
Terminated	yes

Interface characteristics SSI (standard factory setting)	
Data transfer	in slave mode double data transmission
Resolution	0.25 mm
Data length	25 bit + 1 power failure bit (Low)
MSB	first
Code	gray
Clock rate	max. 200 kHz
Monoflop time	< 50 µs
A position value must be read by the SSI master over 52 pulses.	
1 ... 25:	MSB first absolute position in gray code
26:	Data low (PFB)
27 ... 51:	Second transmission (see 1-25)
52:	Data Low (PFB)

Technical data coded band LEX.BA	
Material	V2A spring-loaded stainless steel, chamfered edges
Dimensions	16 x 0.4 mm [0.63 x 0.016"]
Max. length	392 m
Weight	50 g / m [1.76 oz/m]
Thermal expansion	16 x 10 ⁻⁶ / K between 20 °C ... 100 °C

Standards / Directives / Certificates		
Standards	standards for elevators	EN 81-20/21/50
UL compliant	in accordance with	File no. E498900
CE compliant	in accordance with	
	EMC Directive	2014/30/EU
	RoHS Directive	2011/65/EU
	Elevator Directive	2014/33/EU

Shaft copying systems

Sensor – Ants Base	LEB02	Absolute position detection
---------------------------	--------------	------------------------------------

Elevator functions	Standard	Base Sensor
Referencing / correction trip	-	√
Top & bottom inspection limitation	EN 81-20	√
Direct drive-in – depending on complete drive module	-	√
Stopping point shift	-	√
Overspeed during inspection	EN 81-20	√

Terminal assignment

Interface	Type of connection	Cable							
2 CANopen Lift (DS417)	1, A	Signal:	+V	0 V / GND	CAN_H	CAN_L	n.c.	n.c.	
		Core color:	BN	WH	GN	YE	GY	PK	

Interface	Type of connection	Cable with Sub-D, male connector 9-pin										
2 CANopen Lift (DS417)	2, B	Signal:	n.c.	CAN_L	0 V / GND	n.c.	shield	0 V / GND	CAN_H	n.c.	+V	
		Pin:	1	2	3	4	5	6	7	8	9	

Interface	Type of connection	Cable							
3 RS485	1, A	Signal:	+V	0 V / GND	D+	D-	n.c.	n.c.	
		Core color:	BN	WH	GN	YE	GY	PK	

Interface	Type of connection	Cable							
4 SSI	1, A	Signal:	+V	0 V / GND	C+	C-	D+	D-	
		Core color:	BN	WH	GN	YE	GY	PK	

Interface	Type of connection	Cable with Sub-D, male connector 9-pin										
4 SSI	2, B	Signal:	n.c.	C+	shield	D+	0 V / GND	+V	C-	D-	n.c.	
		Pin:	1	2	3	4	5	6	7	8	9	

+V: Supply voltage +V DC
 0 V: Supply voltage ground GND (0 V)

C+, C-: Clock signal
 D+, D-: Data signal

n.c. : Do not connect

Shaft copying systems

Sensor – Ants Base	LEB02	Absolute position detection
---------------------------	--------------	------------------------------------

Technology in detail

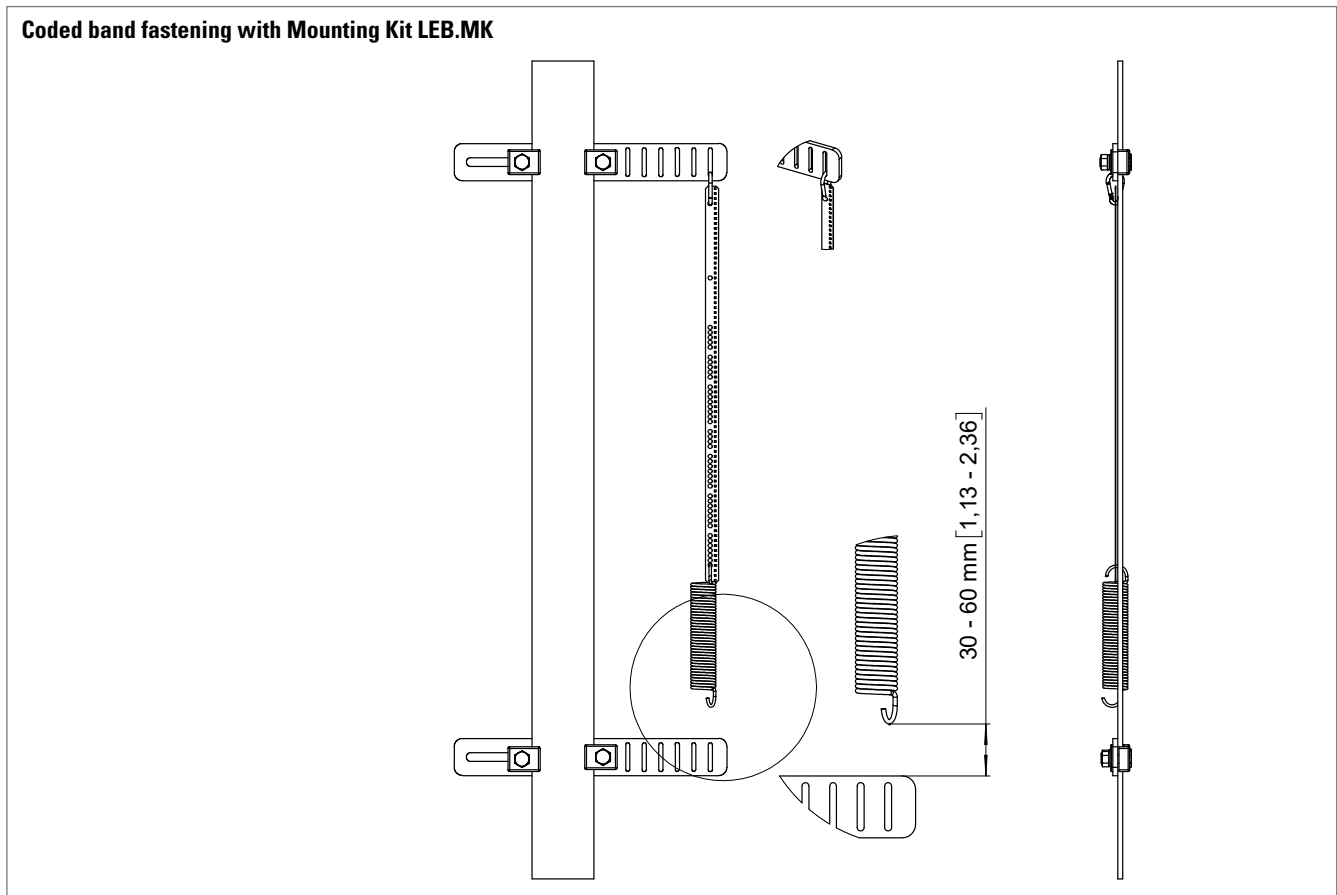

Shaft copying systems

Sensor – Ants Base

LEB02

Absolute position detection

Dimensions

Dimensions in mm [inch]

Sensor

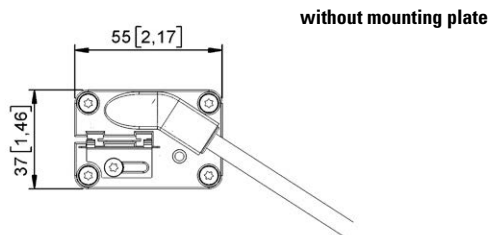
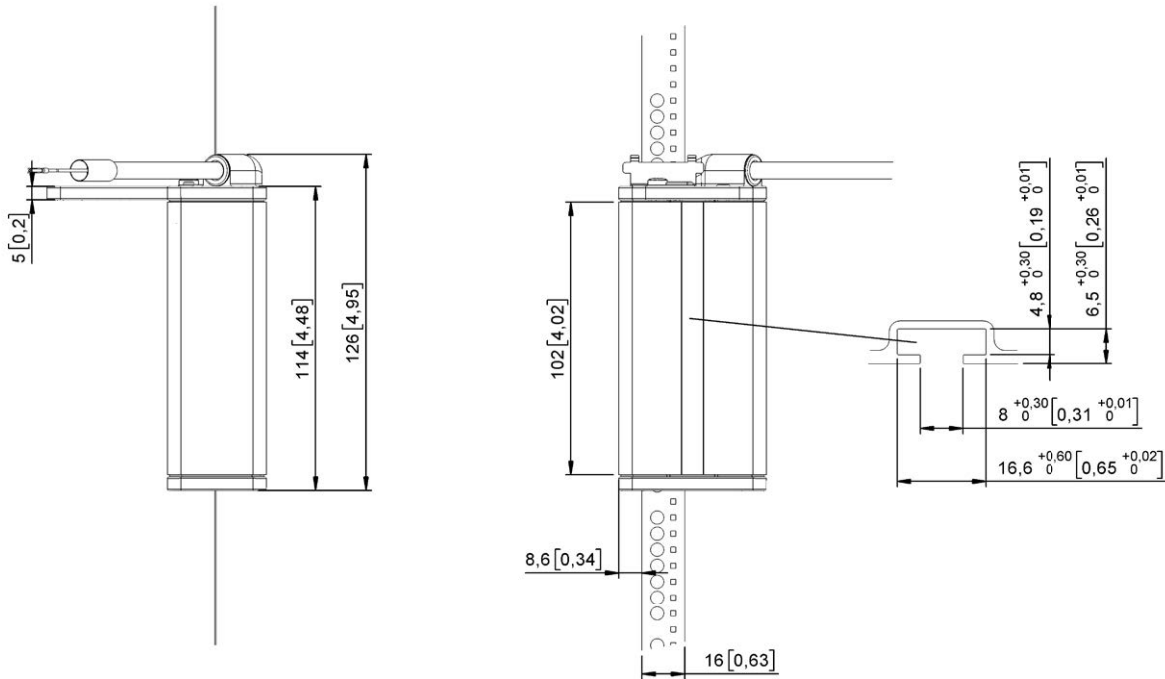

without mounting plate

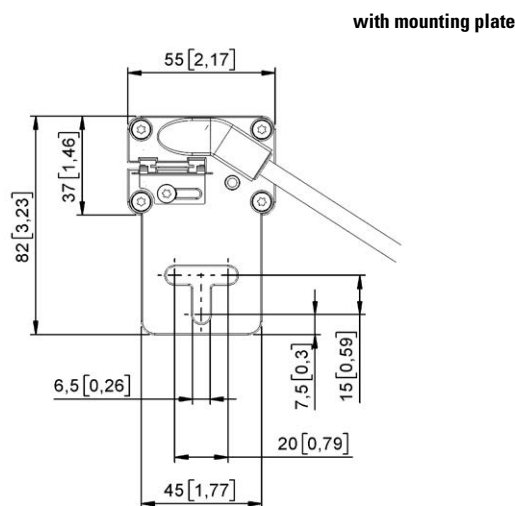

with mounting plate