

Bearingless encoders

Incremental, standard magnetic

RI20 / Limes LI20 (hollow shaft)

Push-pull / RS422

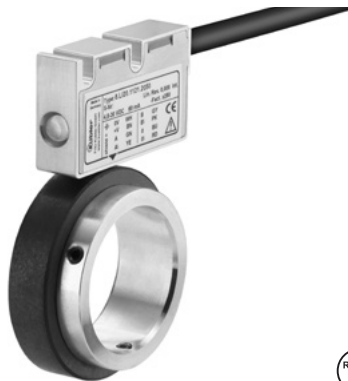

Thanks to its installation depth of only 16 mm, the bearingless magnetic rotary encoder RI20 / Limes LI20, comprising a magnetic ring and sensor head, is ideally suited for plants and machinery where space is very tight. The non-contact measuring principle allows for error-free use even under harsh environmental conditions, as well as ensuring a long service life.

For outdoor use with extremely sturdy aluminum housing and stainless steel cover, wide temperature range as well as a UV-resistant cable. IP68 / IP69k protection, special encapsulation technology and tested resistance to cyclic humidity and damp heat offer the highest levels of reliability, even in exposed outdoor use.



High rotational speed



High protection level



Shock / vibration resistant



Reverse polarity protection

Hard-wearing and robust

- High shock and vibration resistance.
- Sturdy housing with IP67 protection. Option: special housing for maximum resistance against condensation (IP68 / IP69k, resistance to cyclic humidity acc. to EN 60068-3-38 as well as damp heat acc. to EN 60068-3-78).
- Non-contact measuring system, free from wear, ensures a long service life.

Fast start-up

- Requires very little installation space.
- Large mounting tolerance between magnetic band and sensor head.
- Slotted hole fixing ensures simple alignment.
- Function display via LED.

Selection guide magnetic ring RI20 / Limes LI20

Pulses per revolution ¹⁾ (further ppr on request)	Order code magnetic ring RI20	Order code sensor head Limes LI20	Max. rotational speed min ⁻¹ ²⁾
250	8.RI20.031.XXXX.111	8.LI20.11X1.2005	12 000
1 000	8.RI20.031.XXXX.111	8.LI20.11X1.2020	2 400
2 500	8.RI20.031.XXXX.111	8.LI20.11X1.2050	3 900
1 024	8.RI20.041.XXXX.111	8.LI20.11X1.2016	7 000
360	8.RI20.045.XXXX.111	8.LI20.11X1.2005	12 000
3 600	8.RI20.045.XXXX.111	8.LI20.11X1.2050	2 700

Order code Magnetic ring RI20

8.RI20 . XXX . XXXX . 111
Type a b

Min. order quantity for non-stock types: 10 pieces

a Outer diameter

031 = 31 mm [1.22"]
041 = 41.2 mm [1.62"]
045 = 45 mm [1.77"]

b Bore diameter

0800 = 8 mm [0.32"] 1800 = 18 mm [0.71"] 0952 = 3/8"
1000 = 10 mm [0.39"] 2000 = 20 mm [0.79"] 1587 = 5/8"
1200 = 12 mm [0.47"] 2500 = 25 mm [0.98"] ³⁾ 2540 = 1" ³⁾
1500 = 15 mm [0.59"] 3000 = 30 mm [1.18"] ³⁾

Stock types

8.RI20.031.0800.111
8.RI20.031.1000.111
8.RI20.031.1200.111
8.RI20.031.1500.111
8.RI20.041.0800.111
8.RI20.045.1200.111
8.RI20.045.1500.111
8.RI20.045.2500.111
8.RI20.045.2540.111
8.RI20.045.3000.111

1) The pulse rate (ppr) results from the combination of the magnetic sensor with the various outer diameters.

2) With an input frequency of the evaluation unit of 250 kHz.

3) Only possible for outer diameter 045.

Bearingless encoders

Incremental, standard magnetic	RI20 / Limes LI20 (hollow shaft)	Push-pull / RS422
---------------------------------------	---	--------------------------

Order code	8.LI20.X1XX.2XXX		
Sensor head Limes LI20	Type	a	b c d e
a Model 1 = IP67, standard 2 = IP68 / IP69k and humidity tested acc. to EN 60068-3-38, EN 60068-3-78	c Type of connection 1 = cable, 2 m [6.56'] PUR A = radial cable, special length PUR *) *) Available special lengths (connection type A): 3, 5, 8, 10, 15 m [9.84, 16.40, 26.25, 32.80, 49.21'] order code expansion .XXXX = length in dm ex.: 8.LI20.111A.2005.0030 (for cable length 3 m)	d Reference signal 2 = Index periodical	e Interpolation factor 005, 016, 020, 050
b Output circuit / power supply 1 = RS422 / 4.8 ... 26 V DC 2 = Push-pull / 4.8 ... 30 V DC			Stock types 8.LI20.1111.2005 8.LI20.1111.2020 8.LI20.1111.2050 8.LI20.1121.2005 8.LI20.1121.2020 8.LI20.1121.2050

Accessories / Display type 572	Order no.
Position display, 6-digit	with 4 fast switch outputs and serial interface 6.572.0116.D05
	with 4 fast switch outputs and serial interface and scalable analog output 6.572.0116.D95
Position display, 8-digit	with 4 fast switch outputs and serial interface 6.572.0118.D05
	with 4 fast switch outputs and serial interface and scalable analog output 6.572.0118.D95

Further accessories can be found in the accessories section or in the accessories area of our website at: www.kuebler.com/accessories.
Additional connectors can be found in the connection technology section or in the connection technology area of our website at: www.kuebler.com/connection_technology.

Technical data

Mechanical characteristics	
Maximum speed	12000 min ⁻¹
Protection	Model 1 IP67 acc. to EN 60529 Model 2 IP68 / IP69k acc. to EN 60529, DIN 40050-9 and humidity tested acc. to EN 60068-3-38, EN 60068-3-78
Working temperature	-20°C ... +80°C [-4°F ... +176°F]
Shock resistance	5000 m/s ² , 1 ms
Vibration resistance	300 m/s ² , 10 ... 2000 Hz
Pole gap	2 mm from pole to pole
Housing (sensor head)	aluminum
Cable	2 m [6.56'] long, PUR 8 x 0.14 mm ² [AWG 26], shielded, may be used in trailing cable installations
Status LED	green pulse-index red error; speed too high or magnetic fields too weak (8.LI20.XXXX.X050 and 8.LI20.XXXX.X250)
CE compliant acc. to	EMC guideline 2014/30/EU RoHS guideline 2011/65/EU

Signal figures

- 1 Pulse edge interval:
Pay attention to the instructions in the technical data
- 2 Periodic index signal every 2 mm [0.08"]; the logical assignment A, B and 0-signal can change

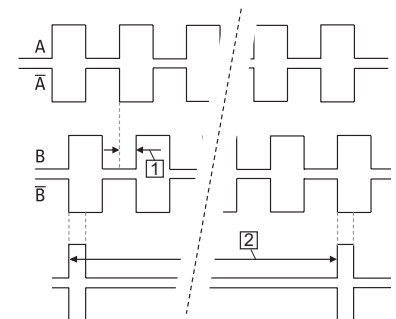

Electrical characteristics		
Output circuit	RS422	Push-pull
Power supply	4.8 ... 26 VDC	4.8 ... 30 VDC
Power consumption (no load)	typ. 25 mA max. 60 mA	typ. 25 mA max. 60 mA
Permissible load / channel	120 Ohm	+/- 20 mA
Min. pulse edge interval	1 µs	1 µs
Signal level	HIGH min. 2.5 V LOW max. 0.5 V	min. +V - 2.0 V max. 0.5 V
Reference signal	index periodical ¹⁾	
System accuracy	typ. 0.3° with shaft tolerance g6	

1) At every pole change. The signal is generated by the sensor.

Bearingless encoders

Incremental, standard magnetic

RI20 / Limes LI20 (hollow shaft)

Push-pull / RS422

Terminal assignment

Output circuit	Type of connection	Cable (isolate unused cores individually before initial start-up)									
		Signal:	0 V	+V	A	\bar{A}	B	\bar{B}	0	$\bar{0}$	\perp
1, 2	1, A	Core color:	WH	BN	GN	YE	GY	PK	BU	RD	shield ¹⁾

- +V: Encoder power supply +V DC
- 0 V: Encoder power supply ground GND (0 V)
- A, \bar{A} : Incremental output channel A / cosine signal
- B, \bar{B} : Incremental output channel B / sine signal
- 0, $\bar{0}$: Reference signal
- \perp : Plug connector housing (shield)

Mounting orientation and permissible mounting tolerances

Distances

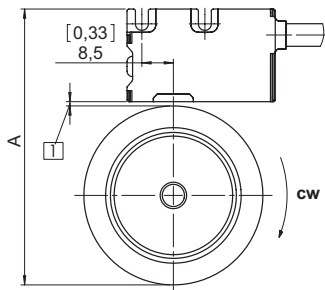

- 1** Distance sensor head / magnetic ring:
0.1 ... 1.0 (0.4 [0.02] recommended)

Magnetic ring	A for distance sensor head / magnetic ring: = 0.4 [0.02]
8.RI20.031.XXXX.111	56.4 [2.22]
8.RI20.041.XXXX.111	66.6 [2.62]
8.RI20.045.XXXX.111	70.4 [2.77]

Torsion

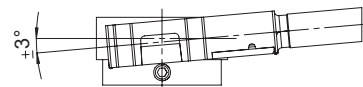

Offset

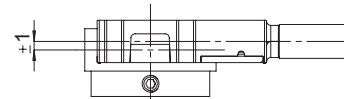

Tilting

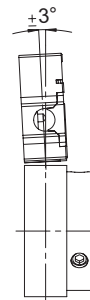

Warning: When mounting the sensor head, please ensure its correct orientation to the magnetic ring!

1) Shield is attached to connector housing.

Bearingless encoders

Incremental, standard magnetic	RI20 / Limes LI20 (hollow shaft)	Push-pull / RS422
---------------------------------------	---	--------------------------

Dimensions

Dimensions in mm [inch]

Sensor head Limes LI20

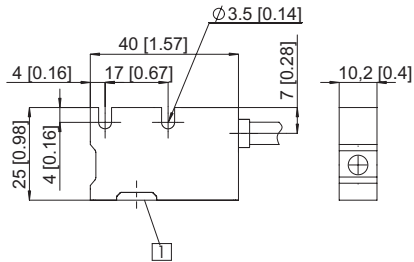

Magnetic ring, \varnothing 31 [1.22], 8.RI20.031.XXXX.111

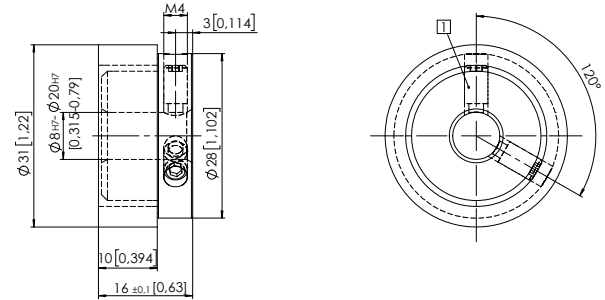

Magnetic ring, \varnothing 41.2 [1.62], 8.RI20.041.XXXX.111

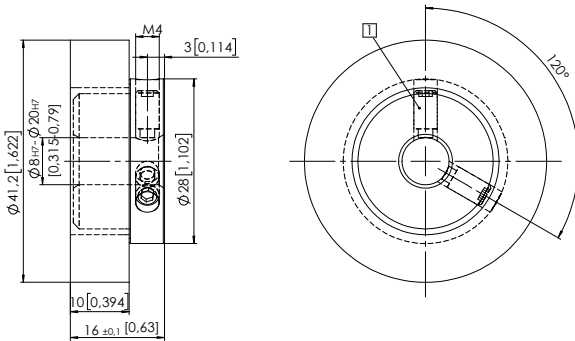

Magnetic ring, \varnothing 45 [1.77], 8.RI20.045.XXXX.111

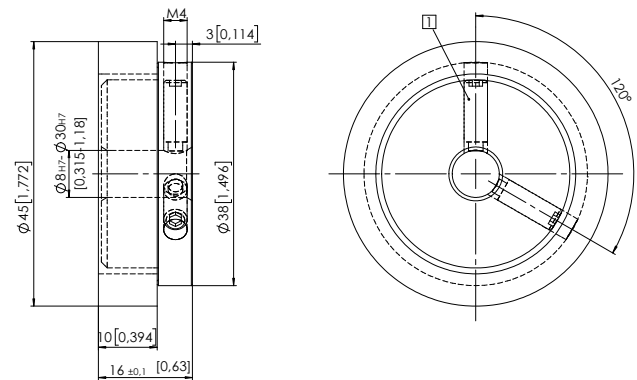

Set screw M4

Recommended tolerance of the drive shaft diameter: g6