

Bearingless encoders

Absolut, standard singleturn, magnetic	RLA50 (hollow shaft)	SSI / CANopen
---	-----------------------------	----------------------



Thanks to its installation depth of only 20 mm, the bearingless magnetic rotary encoder RLA50, comprising a magnetic ring and sensor head, is ideally suited for plants and machinery where space is very tight. The non-contact measuring principle allows for error-free use even under harsh environmental conditions, as well as ensuring a long service life.

This bearingless encoder can be mounted on shafts with a diameter of 30 mm.



High rotational speed	Protection level	Shock / vibration resistant	Reverse polarity protection	Temperature range

Powerful

- High shock and vibration resistance.
- Non-contact measuring system, free from wear, ensures a long service life.
- High resolution, 16,000 measuring steps/revolution.
- Direct measurement on shaft or axis.

Fast start-up

- Distance monitoring by LED.
- Large mounting tolerance between magnetic band and sensor head.
- Requires very little installation space.
- Connection by M12 connector.

Order code	8.RLA50	. 1 3 1 X 2	. 16000	. 0300
	Type	a b c d e	f	g
a Magnetic ring mounting method	1 = Press fit	d Interface	1 = SSI 3 = CANopen	g Bore diameter
b Model	3 = IP40	e Type of connection	2 = M12 connector, 12-pin	Optional on request - other bore diameters - other number of measuring steps - additional incremental signals (HTL, TTL or SinCos) - other baud rate
c Number of poles	1 = 32 pols, pole length 5 mm [0.2"]	f Measuring steps per revolution	16000	

Cables and connectors		Order no.
Preassembled cables	M12 female connector with coupling nut, 12 pin, A coded, straight single ended 5 m [16.40'] PUR cable	05.00.60B1.B211.005M
Connectors	M12 female connector with coupling nut, 12 pin, A coded, straight (metal)	8.0000.5162.0000

Further Kübler cables and connectors can be found at: kuebler.com/connection-technology

Bearingless encoders

Absolut, standard singleturn, magnetic	RLA50 (hollow shaft)	SSI / CANopen
---	-----------------------------	----------------------

Technical data

Mechanical characteristics	
Maximum speed	1000 min ⁻¹
Working temperature	-10 °C ... +70 °C [+14 °F ... +158 °F] (non condensing)
Storage temperature	-25 °C ... +85 °C [-13 °F ... +185 °F]
Protection acc. to EN 60529	IP40
Housing	zinc die-cast
Shock resistance acc. to EN 60068-2-27	5000 m/s ² , 1 ms
Vibration resistance acc. to EN 60068-2-6	300 m/s ² , 10 ... 2000 Hz
Distance sensor head / magnetic band	0.5 ... 1.0 mm (recommended 0.8 mm)
Type of connection (standard)	M12 connector, 12-pin

Electrical characteristics	
Supply voltage	10 ... 30 V DC ±10 %
Residual ripple	< 10 %
Current consumption	max. 150 mA
Reverse polarity protection	yes
Short circuit proof	yes

Accuracy	
Measuring principle	absolute
System accuracy at 20 °C [+68 °F]	±0.35°
Repeat accuracy	±1 increment
Resolution	0.0225°
LED, red	lights up when distance too large

SSI interface	
Output driver	RS485 transceiver type
Permissible load / channel	max. ±20 mA
Signal level	HIGH typ. 3.8 V LOW at I _{Load} = 20 mA typ. 1.3 V
Clock rate	25 bit (24 + 1 failurebit for distance)
Code	binary
SSI clock rate	80 kHz ... 0.4 MHz
Monoflop time	≤ 40 µs
Data refresh rate	≤ 250 µs

CANopen interface	
Interface	CAN High-Speed acc. to ISO 11898, Basic and Full CAN, CAN specification 2.0 B
Protocol	CANopen
Baud rate	standard 250 kbit/s on request other baud rate (125 ... 1000 kbit/s)
Node address	default 1
LSS protocol	CIA LSS protocol DS305 global command support for node address and baud rate selective commands via attributes of the identity object

Approvals	
CE compliant in accordance with	EMC Directive 2014/30/EU RoHS Directive 2011/65/EU
UKCA compliant in accordance with	EMC Regulations S.I. 2016/1091 RoHS Regulations S.I. 2012/3032

Terminal assignment sensor head

Interface	Type of connection	M12 connector, 12-pin													
1	2	Signal:	0 V	+V	C+	C-	D+	D-	-	-	-	-	-	-	-
		Pin:	1	2	3	4	5	6	7	8	9	10	11	12	

Interface	Type of connection	M12 connector, 12-pin													
3	2	Signal:	0 V	+V	CAN_L	CAN_H	-	-	-	-	-	-	-	-	-
		Pin:	1	2	3	4	5	6	7	8	9	10	11	12	

- +V: Supply voltage encoder +V DC
- 0 V: Supply voltage encoder ground GND (0 V)
- C+, C-: Clock signal
- D+, D-: Data signal

Terminal assignment connection cable (accessory)

Connection cable color assignment with M12 female connector	Connection cable with M12 connector, 12 pin (accessory) – 05.00.60B1.B211.005M													
	Core color:	WH	BN	GN	YE	GY	PK	BU	RD	BK	VT	GY/PK	RD/BU	
	Pin:	1	2	3	4	5	6	7	8	9	10	11	12	

Bearingless encoders

Absolut, standard singleturn, magnetic	RLA50 (hollow shaft)	SSI / CANopen
---	-----------------------------	----------------------

Mounting position and permissible mounting tolerances

Sensor distance

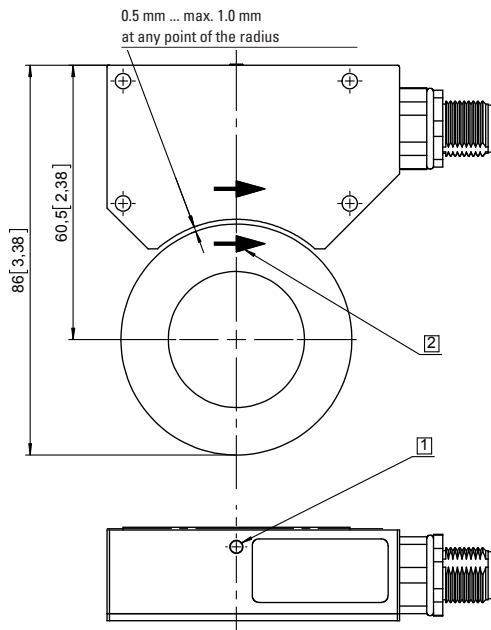

- 1 LED for distance monitoring
- 2 Direction arrows for the assembly
- 3 Fine interpolation track
- 4 Absolute track

Offset

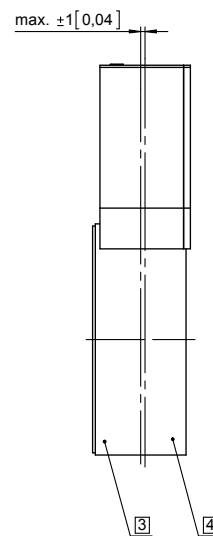

Tilting

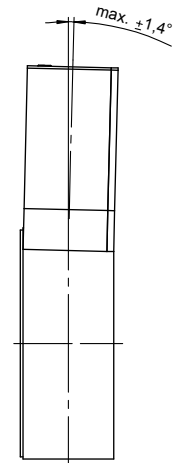

Caution: imperatively comply with the mounting position of the sensor head with respect to the magnetic ring!

Mounting recommendation

Glued assembly

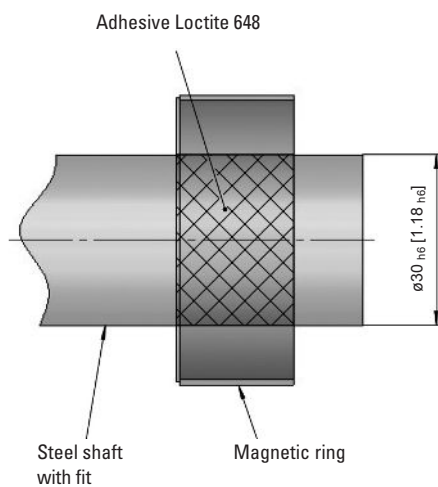

Screwed assembly

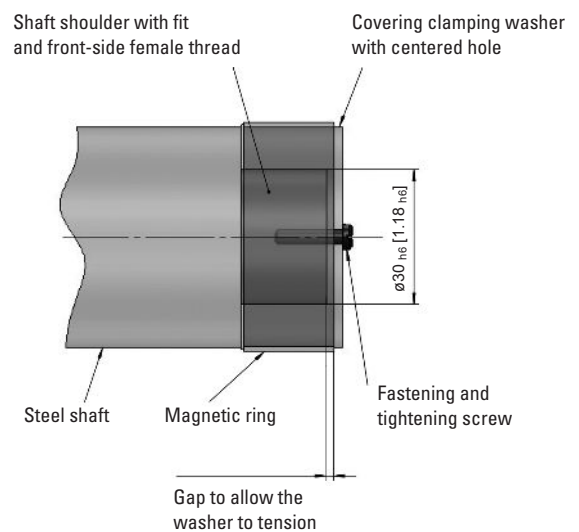

Bearingless encoders

Absolut, standard singleturn, magnetic	RLA50 (hollow shaft)	SSI / CANopen
---	-----------------------------	----------------------

Dimensions

Dimensions in mm [inch]

Sensor head

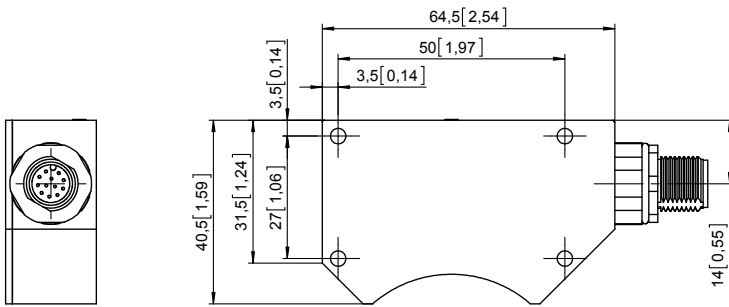

Magnetic ring

