

Slip rings

Modular	Robust	SR160
----------------	---------------	--------------



In general slip rings are used to transmit power, signals or data, pneumatic and hydraulic, from a stationary to a rotating platform.

The transmission between the stator and rotor takes place via sliding contacts and is extremely reliable.

The SR160 is a robust modular slip ring. Its innovative contact technology ensures long maintenance-free operation. Connectors for signals/data and load allow fast and simple installation.

Rugged

- Reliable operation in harsh environments.
- Rugged metal housing.
- High protection level IP65.

Flexible

- Modular construction – individual product.
- Transmission of Ethernet, signal, load, pneumatics and hydraulics.

Reliable

- Pluggable connections – error prevention.
- Innovative contact technology, low-maintenance and durable.
- Transmission rate up to 100 Mbit/s.

Application areas for slip rings

Industrial automation, bottling plants, labelling machines, wear test machines, rotary tables ...

Order code

for standard versions

SR160 - **XX** - **XX** - **XX** - **XX** - **X1X2** - **V100**
Type a b c d e f g h i

a Type of mounting

- 01 = flange mounting, rotor connections radial
- 02 = flange mounting, rotor connections axial

b Number of Ethernet transmissions

- 00 = none
- 01 = Ethernet transmission up to 100 Mbit/s

c Module signal / data channels ¹⁾

- 00 = none
- 02 = 2 channels
- 04 = 4 channels
- 06 = 6 channels
- C0 = CANopen
- D0 = DeviceNet
- M0 = Modbus
- P0 = Profibus

d Module load channels ²⁾

- 00 = none
- 02 = 2 x load
- 04 = 4 x load
- 06 = 6 x load
- L3 = 3 x load + ground PE
- L4 = 4 x load + ground PE

e Load channels max. load current

- 0 = none
- 1 = 230 V / 16 A
- 2 = 230 V / 25 A
- 3 = 400 V / 10 A
- 4 = 400 V / 20 A

f Type of connection

- 1 = connector

g Central lead-through

- 0 = none
- 1 = air connection 1/4"
- 2 = air connection 1/2"
- 3 = air connection 3/8"
- A = central bore, inside diameter 20 mm
- B = central bore, inside diameter 15 mm

h Protection rating

- 2 = IP65

i Version number (options)

- V100 = without options
- >V100 = options on request, e.g.:
 - > 20 channels
 - other types of mounting
 - other types of connection (cable, connector, ...)
 - hydraulics connection

Connection technology		Order no.
Cordset, pre-assembled	M12 male connector with external thread, 4-pin 2 m [6.56'] PUR cable	05.00.6031.4411.002M
Connector, self-assembly (straight)	M12 male connector with external thread, 4-pin	05.WASCSY4S
Industrial Ethernet - cable	PUR electronic cable	05.00.6031.1111.XXXM ³⁾

Additional connectors can be found in the connection technology section or in the connection technology area of our website at: www.kuebler.com/connection_technology.

1) Additional signal / data channels on request (option)

e.g. C2 = CAN module expansion with 2 additional channels
 Connection lines for CAN and signal transmission separated on stator and rotor side.

2) Additional load channels on request (option).

3) XXXX = cable length in meters (e.g. 10 m = 0010).

Slip rings

Modular	Robust	SR160
----------------	---------------	--------------

Technical data	
Overall length	dep. on the number of transmission paths
Type of connection (stator and rotor)	load M23 connector signal / data M12 connector Ethernet M12 connector 4-pin, D coded
Material pairing	load copper / bronze signal / data silver / precious metal Ethernet silver / precious metal
Voltage/current loading	
load channels	order option 1 230 V AC/DC, max. 16 A, 50/60 Hz order option 2 230 V AC/DC, max. 25 A, 50/60 Hz order option 3 400 V AC/DC, max. 10 A, 50/60 Hz order option 4 400 V AC/DC, max. 20 A, 50/60 Hz
signal channels	48 V AC/DC, max. 2 A
Contact resistance	load channels $\leq 1 \text{ Ohm (dynamic)}^{1)}$ signal / data channels $\leq 0.1 \text{ Ohm (silver / precious metal)}^{2)}$
Insulation resistance	$10^3 \text{ MOhm, at } 500 \text{ V DC}$
Dielectric strength	$1000 \text{ V eff. (60 sec.)}$
Speed max. (signal / data channels)	150 min^{-1} (depends on installation position and numbers of channels)
Service life (signal / data channels)	typ. 500 million revolutions (at room temperature) depends on installation position

Maintenance cycles	maintenance free (if necessary all 100 million revolutions)
Maintenance	Remove contact abrasion dust – do not use compressed air
Operating temperature	$-35^\circ \dots +85^\circ \text{C} [-31^\circ \text{F} \dots +185^\circ \text{F}]$
Protection acc. to EN 60529	max. IP65
Transmission paths	max. 20 (> 20 on request)

Air connection (media lead-through no. 1 - 3)	
Air pressure max.	10 bar (150 psi)
Vacuum max.	7 kPa (2" Hg)
Speed max.	150 min^{-1}

Slip rings

Technology in detail

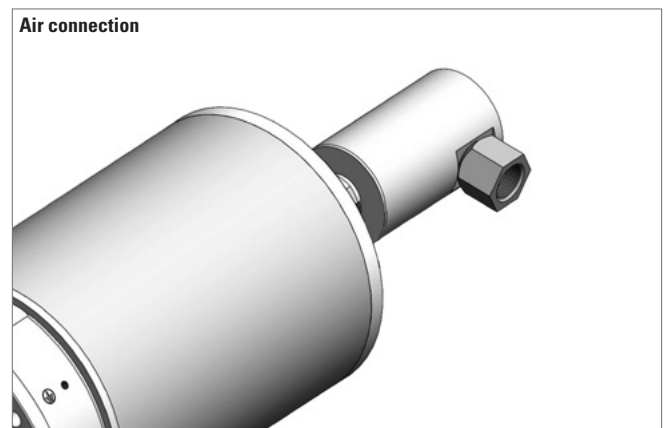
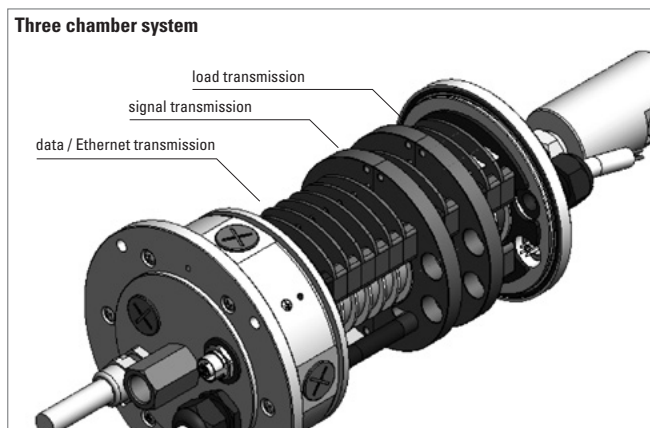

1) Voltage measurement, ambient temperature, DC series connection, ohmic load, min. 4 A test current.
 2) 2-wire resistance measurement, ambient temperature, 6.5-digit digital multimeter or similar, values without testing cable.

Slip rings

Modular	Robust	SR160
----------------	---------------	--------------

Terminal assignment

M12 connector, 4-pin, EtherNet transmission						Stator IN	Rotor OUT			
Signal:	Transmit data +	Receive data +	Transmit data -	Receive data -		 D coded	 D coded			
Abbreviation:	TxD+	RxD+	TxD-	RxD-						
Pin:	1	2	3	4						
M12 connector, 5-pin, module Profibus						Stator IN	Rotor OUT			
Channel:	1	2	3	4	5	6	 B coded	 B coded		
Pin:	1	2	3	4	5	PH				
M12 connector, 5-pin, module DeviceNet, CANopen, Modbus						Stator IN	Rotor OUT			
Channel:	1	2	3	4	5	6	 A coded	 A coded		
Pin:	1	2	3	4	5	PH				
M12 connector, 8-pin, signal / data channels						Stator IN	Rotor OUT			
Channel:	1	2	3	4	5	6	7	8	 A coded	 A coded
Pin:	1	2	3	4	5	6	7	8		
M23 connector, 6-pin, load channels						Stator IN	Rotor OUT			
Channel:	1	2	3	4	5	PE	 A coded	 A coded		
Pin:	1	2	4	5	6	⊥				

Dimensions

Dimensions in mm [inch]

Standard version

Example: Type SR160-01-01-06-04-3132-V100

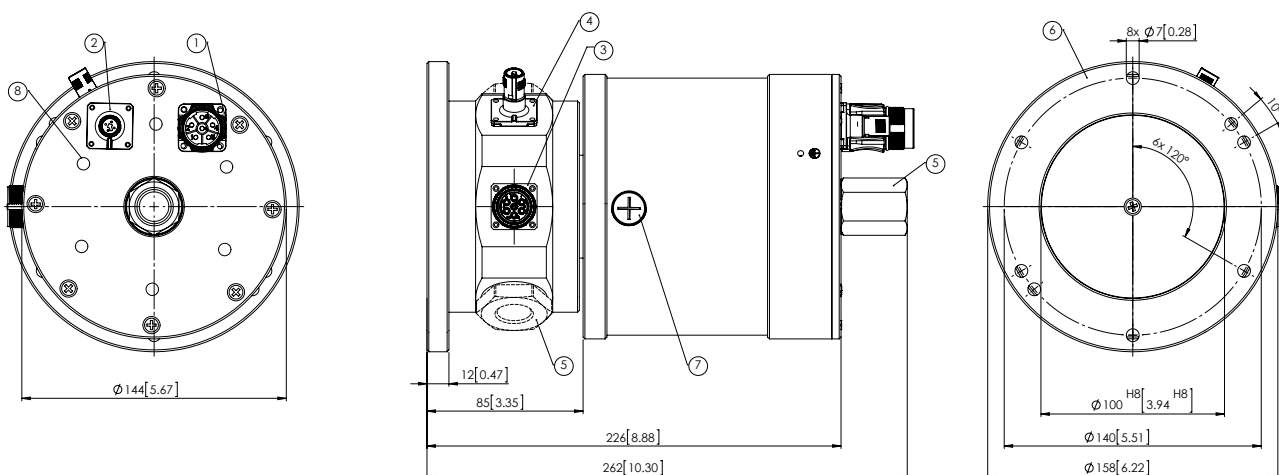

- 1 – Stator power connection, M23 connector
- 2 – Stator signal connection, M12 connector (coding depending on interface)
- 3 – Rotor power connection, M23 connector

- 4 – Rotor signal connection, M12 connector (coding depending on interface)
- 5 – Rotor media connection (optional)
- 6 – Mounting flange
- 7 – Maintenance opening (on both sides)